Section 17. UART

HIGHLIGHTS

This section of the manual contains the following major topics:

17.1	Introduction	17-2
17.2	Control Registers	17-4
17.3	UART Baud Rate Generator	17-10
17.4	UART Configuration	17-12
17.5	UART Transmitter	17-13
17.6	Data Bit Detection	17-18
17.7	UART Receiver	17-19
17.8	Using the UART for 9-bit Communication	17-24
17.9	Other Features of the UART	17-26
17.10	UART Operation with DMA	17-27
17.11	UART Operation During CPU Sleep and Idle Modes	17-31
17.12	Operation of UxCTS and UxRTS Control Pins	17-33
17.13	Infrared Support	17-35
17.14	LIN Support	17-38
17.15	Register Map	17-40
17.16	Design Tips	17-41
17.17	Related Application Notes	17-42
17.18	Revision History	17-43

Note: This family reference manual section is meant to serve as a complement to device data sheets. Depending on the device variant, this manual section may not apply to all dsPIC33F/PIC24H devices.

Please consult the note at the beginning of the “**UART**” chapter in the current device data sheet to check whether this document supports the device you are using.

Device data sheets and family reference manual sections are available for download from the Microchip Worldwide Web site at: <http://www.microchip.com>

17.1 INTRODUCTION

The Universal Asynchronous Receiver Transmitter (UART) module is one of the serial I/O modules available in the dsPIC33F/PIC24H device family. The UART is a full-duplex, asynchronous communication channel that communicates with peripheral devices and personal computers using protocols such as RS-232, RS-485, LIN and IrDA®. The module also supports the hardware flow control option with UxCTS and UxRTS pins and includes the IrDA encoder and decoder.

The primary features of the UART module are as follows:

- Full-Duplex, 8-bit or 9-bit Data Transmission through the UxTX and UxRX pins
- Even, Odd or No Parity options (for 8-bit data)
- One or two Stop bits
- Hardware Auto-Baud feature
- Hardware Flow Control option with \overline{UxCTS} and \overline{UxRTS} pins
- Fully Integrated Baud Rate Generator (BRG) with 16-bit Prescaler
- Baud Rates ranging from 10 Mbps to 38 bps at 40 MIPS
- 4-deep First-In-First-Out (FIFO) Transmit Data Buffer
- 4-deep FIFO Receive Data Buffer
- Parity, Framing, and Buffer Overrun Error Detection
- Support for 9-bit mode with Address Detect (9th bit = 1)
- Transmit and Receive Interrupts
- Loopback mode for Diagnostic Support
- IrDA Encoder and Decoder Logic
- LIN Bus Support
- 16x Baud Clock Output for External IrDA Encoder/Decoder support

Note: Each dsPIC33F/PIC24H family device variant may have one or more UART modules. An 'x' used in the names of pins, control/status bits and registers denotes the UART module number. For more information, refer to the specific device data sheets.

A simplified block diagram of the UART is illustrated in Figure 17-1. The UART module consists of the following key hardware elements:

- Baud Rate Generator
- Asynchronous Transmitter
- Asynchronous Receiver

Figure 17-1: UART Simplified Block Diagram

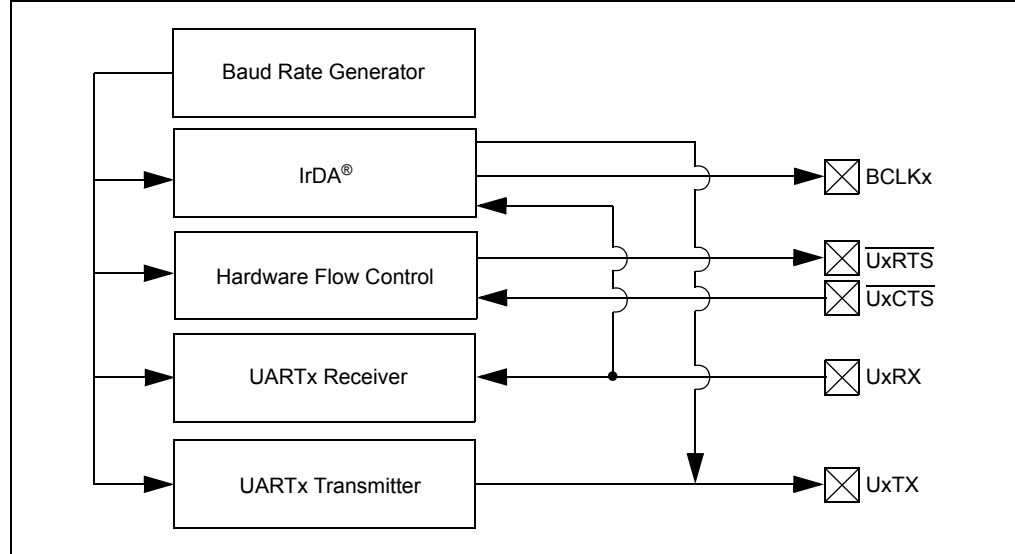

17.2 CONTROL REGISTERS

This section outlines the specific functions of each register that controls the operation of the UART module:

- **UxMODE: UARTx Mode Register**
 - Enables or disables the UART module
 - Enables or disables the IrDA encoder and decoder
 - Enables or disables the WAKE, ABAUD and Loopback features
 - Enables or disables the $\overline{\text{UxRTS}}$ and $\overline{\text{UxCTS}}$ pins
 - Configures the $\overline{\text{UxRTS}}$ pin for the desired mode of operation
 - Configures the polarity of the UxRx pin
 - Selects the type of baud rate
 - Selects the number of data bits, parity, and Stop bits
- **UxSTA: UARTx Status and Control Register**
 - Selects the Transmission Interrupt mode
 - Selects the Receive Interrupt mode
 - Enables or disables the UART transmission
 - Controls the Address Detect mode
 - Indicates various status conditions, such as transmit and receive buffer state, parity error, framing error, and overflow error
- **UxRXREG: UARTx Receive Register**
 - Stores the received data
- **UxTXREG: UARTx Transmit Register (Write-Only)**
 - Provides the data to be transmitted
- **UxBRG: UARTx Baud Rate Register**
 - Stores the baud rate value of the transmitted or received data

Register 17-1: UxMODE: UARTx Mode Register

R/W-0	U-0	R/W-0	R/W-0	R/W-0	U-0	R/W-0	R/W-0
UARTEN	—	USIDL	IREN ⁽¹⁾	RTSMD	—	UEN<1:0>	
bit 15							bit 8

R/W-0	R/W-0	R/W-0	R/W-0	R/W-0	R/W-0	R/W-0	R/W-0
WAKE	LPBACK	ABAUD	URXINV	BRGH	PDSEL<1:0>		STSEL
bit 7							bit 0

Legend:

R = Readable bit	W = Writable bit	U = Unimplemented bit, read as '0'
-n = Value at POR	'1' = Bit is set	'0' = Bit is cleared x = Bit is unknown

- bit 15 **UARTEN:** UARTx Enable bit
 1 = UARTx is enabled; UARTx pins are controlled by UARTx as defined by the UEN<1:0> and UTXEN control bits
 0 = UARTx is disabled; UARTx pins are controlled by the corresponding PORT, LAT and TRIS bits
- bit 14 **Reserved**
- bit 13 **USIDL:** Stop in Idle Mode bit
 1 = Discontinue operation when the device enters Idle mode
 0 = Continue operation in Idle mode
- bit 12 **IREN:** IrDA Encoder and Decoder Enable bit⁽¹⁾
 1 = IrDA encoder and decoder are enabled
 0 = IrDA encoder and decoder are disabled
- bit 11 **RTSMD:** Mode Selection for $\overline{\text{UxRTS}}$ Pin bit
 1 = $\overline{\text{UxRTS}}$ is in Simplex mode
 0 = $\overline{\text{UxRTS}}$ is in Flow Control mode
- bit 10 **Reserved**
- bit 9-8 **UEN<1:0>:** UARTx Enable bits
 11 = $\overline{\text{UxTX}}$, $\overline{\text{UxRX}}$ and $\overline{\text{BCLKx}}$ pins are enabled and used; $\overline{\text{UxCTS}}$ pin is controlled by port latches
 10 = $\overline{\text{UxTX}}$, $\overline{\text{UxRX}}$, $\overline{\text{UxCTS}}$ and $\overline{\text{UxRTS}}$ pins are enabled and used
 01 = $\overline{\text{UxTX}}$, $\overline{\text{UxRX}}$ and $\overline{\text{UxRTS}}$ pins are enabled and used; $\overline{\text{UxCTS}}$ pin is controlled by port latches
 00 = $\overline{\text{UxTX}}$ and $\overline{\text{UxRX}}$ pins are enabled and used; $\overline{\text{UxCTS}}$, $\overline{\text{UxRTS}}$ and $\overline{\text{BCLKx}}$ pins are controlled by port latches
- bit 7 **WAKE:** Enable Wake-up on Start bit Detect During Sleep Mode bit
 1 = Wake-up is enabled
 0 = Wake-up is disabled
- bit 6 **LPBACK:** UARTx Loopback Mode Select bit
 1 = Enable Loopback mode
 0 = Loopback mode is disabled
- bit 5 **ABAUD:** Auto-Baud Enable bit
 1 = Enable baud rate measurement on the next character. Requires reception of a Sync field (0x55); cleared in hardware upon completion
 0 = Baud rate measurement disabled or completed
- bit 4 **URXINV:** Receive Polarity Inversion bit
 1 = $\overline{\text{UxRX}}$ Idle state is '0'
 0 = $\overline{\text{UxRX}}$ Idle state is '1'

Note 1: This feature is only available for Low-Speed mode (BRGH = 0). For more information, refer to the specific device data sheet.

dsPIC33F/PIC24H Family Reference Manual

Register 17-1: UxMODE: UARTx Mode Register (Continued)

bit 3	BRGH: High Baud Rate Select bit 1 = High-speed mode 0 = Low-speed mode
bit 2-1	PDSEL<1:0>: Parity and Data Selection bits 11 = 9-bit data, no parity 10 = 8-bit data, odd parity 01 = 8-bit data, even parity 00 = 8-bit data, no parity
bit 0	STSEL: Stop Selection bit 1 = 2 Stop bits 0 = 1 Stop bit

Note 1: This feature is only available for Low-Speed mode (BRGH = 0). For more information, refer to the specific device data sheet.

Register 17-2: UxSTA: UARTx Status and Control Register

R/W-0	R/W-0	R/W-0	U-0	R/W-0	R/W-0	R-0	R-1
UTXISEL1	UTXINV	UTXISEL0	—	UTXBRK	UTXEN	UTXBF	TRMT
bit 15							bit 8

R/W-0	R/W-0	R/W-0	R-1	R-0	R-0	R/C-0	R-0
URXISEL<1:0>		ADDEN	RIDLE	PERR	FERR	OERR	URXDA
bit 7							bit 0

Legend:	C = Clearable bit
R = Readable bit	W = Writable bit
-n = Value at POR	'1' = Bit is set
	U = Unimplemented bit, read as '0'
	'0' = Bit is cleared
	x = Bit is unknown

- bit 15,13 **UTXISEL<1:0>**: Transmission Interrupt Mode Selection bits
 - 11 = Reserved
 - 10 = Interrupt is generated when a character is transferred to the Transmit Shift register and the transmit buffer becomes empty
 - 01 = Interrupt is generated when the last transmission is over (that is, the last character is shifted out of the Transmit Shift register) and all the transmit operations are completed
 - 00 = Interrupt generated when any character is transferred to the Transmit Shift register (which implies at least one location is empty in the transmit buffer)
- bit 14 **UTXINV**: Transmit Polarity Inversion bit
 - If IREN = 0:
 - 1 = UxTX Idle state is '0'
 - 0 = UxTX Idle state is '1'
 - If IREN = 1:
 - 1 = IrDA encoded, UxTX Idle state is '1'
 - 0 = IrDA encoded, UxTX Idle state is '0'
- bit 12 **Unimplemented**: Read as '0'
- bit 11 **UTXBRK**: Transmit Break bit
 - 1 = UxTX pin is driven low regardless of the transmitter state (Sync Break transmission – Start bit followed by twelve '0's and a Stop bit)
 - 0 = Sync Break transmission is disabled or completed
- bit 10 **UTXEN**: Transmit Enable bit
 - 1 = UARTx transmitter enabled; UxTX pin is controlled by UARTx (if UARTEN = 1)
 - 0 = UARTx transmitter disabled; any pending transmission is aborted and the buffer is reset; UxTX pin is controlled by PORT
- bit 9 **UTXBF**: Transmit Buffer Full Status bit (read-only)
 - 1 = Transmit buffer is full
 - 0 = Transmit buffer is not full; at least one more data word can be written
- bit 8 **TRMT**: Transmit Shift Register is Empty bit (read-only)
 - 1 = Transmit Shift register is empty and the transmit buffer is empty (that is, the last transmission has completed)
 - 0 = Transmit Shift register is not empty; a transmission is in progress or queued in the transmit buffer
- bit 7-6 **URXISEL<1:0>**: Receive Interrupt Mode Selection bits
 - 11 = Interrupt flag bit is set when the receive buffer is full (that is, receive buffer has 4 data characters)
 - 10 = Interrupt flag bit is set when the receive buffer is 3/4 full (that is, receive buffer has 3 data characters)
 - 0x = Interrupt flag bit is set when a character is received
- bit 5 **ADDEN**: Address Character Detect bit (bit 8 of received data = 1)
 - 1 = Address Detect mode enabled. If 9-bit mode is not selected, this control bit has no effect.
 - 0 = Address Detect mode disabled

Register 17-2: UxSTA: UARTx Status and Control Register (Continued)

- bit 4 **RIDLE**: Receiver Idle bit (read-only)
1 = Receiver is Idle
0 = Data is being received
- bit 3 **PERR**: Parity Error Status bit (read-only)
1 = Parity error is detected for the current character
0 = Parity error is not detected
- bit 2 **FERR**: Framing Error Status bit (read-only)
1 = Framing error is detected for the current character
0 = Framing error is not detected
- bit 1 **OERR**: Receive Buffer Overrun Error Status bit (clear/read-only)
1 = Receive buffer has overflowed
0 = Receive buffer has not overflowed. (Clearing a previously set OERR bit will reset the receive buffer and RSR to an empty state.)
- bit 0 **URXDA**: Receive Buffer Data Available bit (read-only)
1 = Receive buffer has data; at least one more character can be read
0 = Receive buffer is empty

Register 17-3: UxRXREG: UARTx Receive Register

U-0	U-0	U-0	U-0	U-0	U-0	U-0	R-0
—	—	—	—	—	—	—	URX8
bit 15							bit 8
R-0	R-0	R-0	R-0	R-0	R-0	R-0	R-0
URX<7:0>							
bit 7							bit 0

Legend:

R = Readable bit W = Writable bit U = Unimplemented bit, read as '0'
 -n = Value at POR '1' = Bit is set '0' = Bit is cleared x = Bit is unknown

bit 15-9 **Unimplemented:** Read as '0'
 bit 8 **URX8:** Data bit number 8 of the Received Character (in 9-bit mode)
 bit 7-0 **URX<7:0>:** Data bits 7-0 of the Received Character

Register 17-4: UxTXREG: UARTx Transmit Register (Write-Only)

U-0	U-0	U-0	U-0	U-0	U-0	U-0	W-x
—	—	—	—	—	—	—	UTX8
bit 15							bit 8
W-x	W-x	W-x	W-x	W-x	W-x	W-x	W-x
UTX<7:0>							
bit 7							bit 0

Legend:

R = Readable bit W = Writable bit U = Unimplemented bit, read as '0'
 -n = Value at POR '1' = Bit is set '0' = Bit is cleared x = Bit is unknown

bit 15-9 **Unimplemented:** Read as '0'
 bit 8 **UTX8:** Data bit number 8 of the Transmitted Character (in 9-bit mode)
 bit 7-0 **UTX<7:0>:** Data bits 7-0 of the Transmitted Character

Register 17-5: UxBRG: UARTx Baud Rate Register

R/W-0	R/W-0	R/W-0	R/W-0	R/W-0	R/W-0	R/W-0	W-0
BRG<15:8>							
bit 15							bit 8
R/W-0	R/W-0	R/W-0	R/W-0	R/W-0	R/W-0	R/W-0	R/W-0
BRG<7:0>							
bit 7							bit 0

Legend:

R = Readable bit W = Writable bit U = Unimplemented bit, read as '0'
 -n = Value at POR '1' = Bit is set '0' = Bit is cleared x = Bit is unknown

bit 15-0 **BRG<15:0>:** Baud Rate Divisor bits

17.3 UART BAUD RATE GENERATOR

The UART module includes a dedicated 16-bit Baud Rate Generator (BRG). The UxBRG register controls the period of a free-running, 16-bit timer. Equation 17-1 provides the formula for computing the Baud rate with BRGH = 0.

Equation 17-1: UART Baud Rate (BRGH = 0)

$$\text{Baud Rate} = \frac{F_{CY}}{16 \times (UxBRG + 1)} \dots\dots(1)$$

$$UxBRG = \frac{F_{CY}}{16 \times \text{Baud Rate}} - 1 \dots\dots(2)$$

Note: F_{CY} denotes the instruction cycle clock frequency ($F_{OSC}/2$).

Example 17-1 provides the calculation of the Baud rate error for the following conditions:

- $F_{CY} = 4 \text{ MHz}$
- Desired Baud Rate = 9600

Example 17-1: Baud Rate Error Calculation (BRGH = 0)

$$\text{Desired Baud Rate} = \frac{F_{CY}}{16 \times (UxBRG + 1)} \dots\dots(1)$$

Solving for UxBRG value:

$$\begin{aligned} UxBRG &= \frac{F_{CY}/\text{Desired Baud Rate}}{16} - 1 \\ &= \left(\frac{4000000/9600}{16} - 1 \right) \\ &= 25 \end{aligned}$$

$$\begin{aligned} \text{Calculated Baud Rate} &= \frac{4000000}{16 \times (25 + 1)} \\ &= 9615 \end{aligned}$$

$$\begin{aligned} \text{Error} &= \frac{\text{Calculated Baud Rate} - \text{Desired Baud Rate}}{\text{Desired Baud Rate}} \dots\dots(2) \\ &= \frac{9615 - 9600}{9600} \\ &= 0.16\% \end{aligned}$$

The maximum Baud rate (BRGH = 0) possible is $F_{CY}/16$ (for $UxBRG = 0$), and the minimum Baud rate possible is $F_{CY}/(16 * 65536)$.

Equation 17-2 shows the formula for computing the Baud rate with BRGH = 1.

Equation 17-2: UART Baud Rate (BRGH = 1)

$$Baud\ Rate = \frac{F_{CY}}{4 \times (UxBRG + 1)} \dots\dots(1)$$

$$UxBRG = \frac{F_{CY}}{4 \times Baud\ Rate} - 1 \dots\dots(2)$$

Note: F_{CY} denotes the instruction cycle clock frequency.

The maximum Baud rate (BRGH = 1) possible is $F_{CY}/4$ (for $UxBRG = 0$), and the minimum Baud rate possible is $F_{CY}/(4 * 65536)$.

Writing a new value to the $UxBRG$ register causes the BRG timer to be reset (cleared). This ensures the BRG does not wait for a timer overflow before generating the new Baud rate.

17.3.1 BCLKx Output

The BCLKx pin will output the 16x Baud clock if the UART and BCLKx output are enabled ($UEN<1:0> = 11$). This feature is used for external IrDA encoder/decoder support (see Figure 17-2). BCLKx output stays high during Sleep mode. BCLKx is forced as an output as long as the UART is kept in ($UEN<1:0> = 11$) mode, regardless of the PORTx and TRISx latch bits.

Figure 17-2: BCLKx Output vs. UxBRG Programming

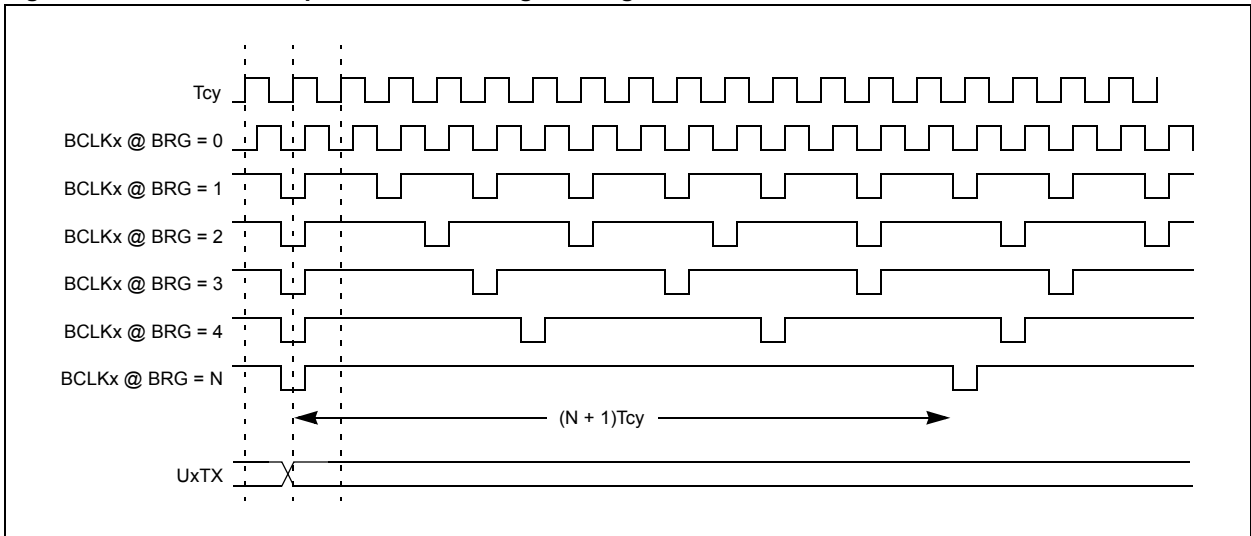

17.4 UART CONFIGURATION

The UART uses standard Non-Return-to-Zero (NRZ) format (one Start bit, eight or nine data bits, and one or two Stop bits). Parity is supported by the hardware and may be configured by the user application as even, odd, or no parity. The most common data format is 8-bit, no parity, and one Stop bit (denoted as 8, N, 1), which is the default (POR) setting. The number of data bits and Stop bits and the parity are specified in the PDSEL<1:0> bit (UxMODE<2:1>) and STSEL bit (UxMODE<0>). An on-chip, dedicated 16-bit BRG can be used to derive standard baud rate frequencies from the oscillator. The UART transmits and receives the Least Significant bit (LSb) first. The UART module's transmitter and receiver are functionally independent, but use the same data format and baud rate.

17.4.1 Enabling the UART

The UART module is enabled by setting the UARTEN bit (UxMODE<15>) and UTXEN bit (UxSTA<10>). After enabled, the UxTX and UxRX pins are configured as an output and input respectively overriding the TRIS and PORT register bit settings for the corresponding I/O port pins. The UxTX pin is at logic '1' when no transmission is taking place.

Note: The UTXEN bit should not be set until the UARTEN bit is set; otherwise, UART transmissions will not be enabled.
--

17.4.2 Disabling the UART

The UART module is disabled by clearing the UARTEN bit (UxMODE<15>). This is the default state after any Reset. If UART is disabled, all UART pins operate as port pins under the control of their corresponding PORT and TRIS bits.

Disabling the UART module resets the buffers to empty states. Any data characters in the buffers are lost and the baud rate counter is reset.

All errors and status flags associated with the UART module are reset when the module is disabled. The URXDA, OERR, FERR, PERR, UTXEN, UTXBRK and UTXBF bits are cleared, whereas the RIDLE and TRMT bits are set. Other control bits (including ADDEN, URXISEL<1:0> and UTXISEL<1:0>) and the UxMODE and UxBRG registers are not affected.

Clearing the UARTEN bit while the UART is active will abort all pending transmissions and receptions, and resets the module as defined above. Re-enabling the UART will restart the UART in the same configuration.

17.5 UART TRANSMITTER

The UART transmitter block diagram is illustrated in Figure 17-3. The heart of the transmitter is the Transmit Shift register (UxTSR). The Shift register obtains its data from the transmit FIFO buffer, UxTXREG. The UxTXREG register is loaded with data in software. The UxTSR register is not loaded until the Stop bit is transmitted from the previous load. As soon as the Stop bit is transmitted, the UxTSR is loaded with new data from the UxTXREG register (if available).

Note: The UxTSR register is not mapped in data memory, hence it is not available to the user application.

Figure 17-3: UART Transmitter Block Diagram

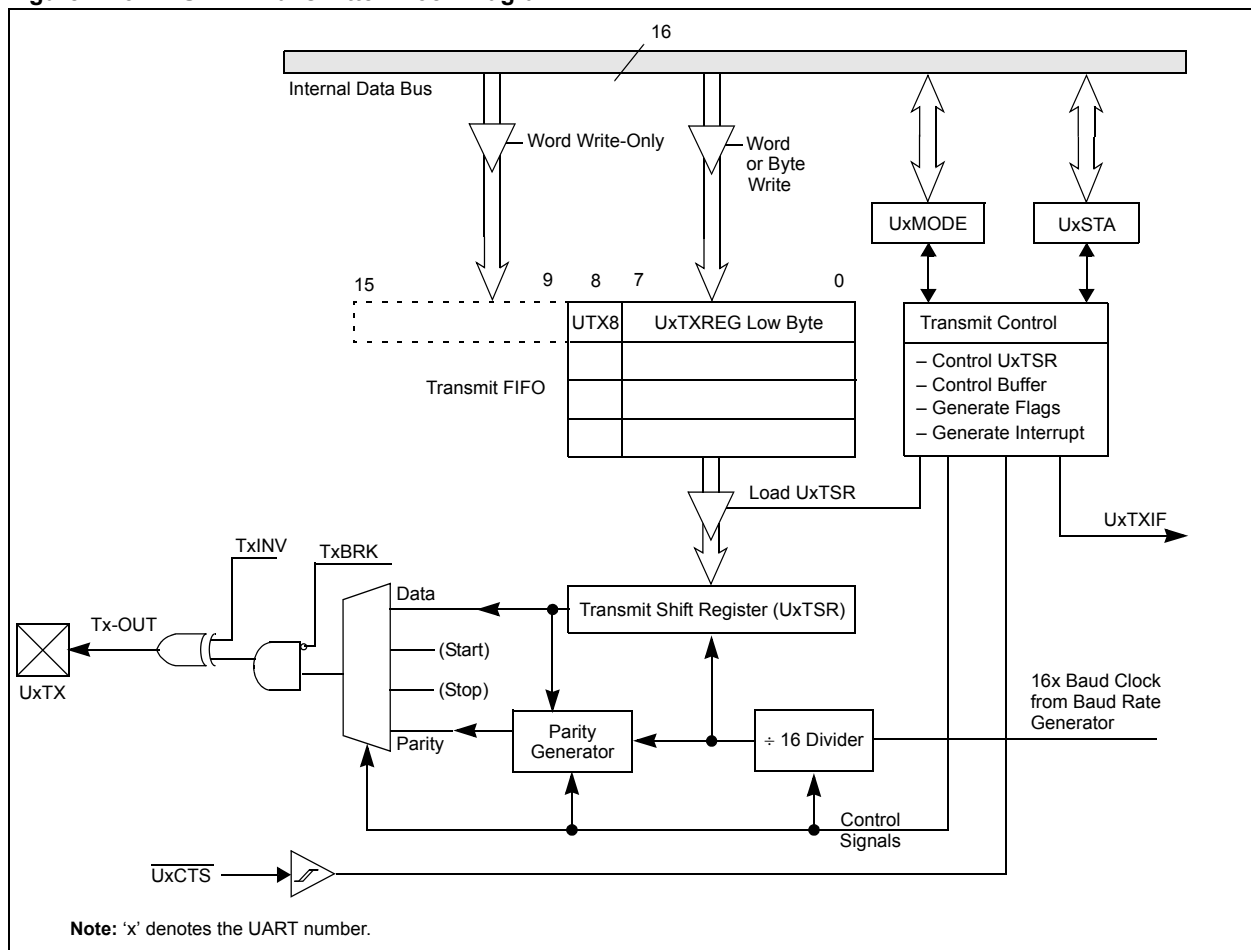

Transmission is enabled by setting the UTXEN enable bit (UxSTA<10>). The transmission does not occur until the UxTXREG register is loaded with data and the Baud Rate Generator (UxBRG) has produced a shift clock (Figure 17-3). Usually, when transmission is started, the UxTSR register is empty, because a transfer to the UxTXREG register results in an immediate transfer to UxTSR. Clearing the UTXEN bit during a transmission causes the transmission to be aborted and will reset the transmitter. As a result, the UxTX pin will revert to a high-impedance state.

To select 9-bit transmission, the PDSEL<1:0> bits (UxMODE<2:1>) should be set to '11' and the ninth bit should be written to the UTX8 bit (UxTXREG<8>). A word write should be performed to UxTXREG so that all nine bits are written simultaneously.

Note: No parity in the case of a 9-bit data transmission.

On a device reset, the UxTX pin is configured as an input; therefore, the state of the UxTX pin is undefined. When the UART module is enabled, the transmit pin is driven high and it remains in this state until data is written to the transmit buffer (UxTXREG). The transmit pin is driven low as soon as the first data is written to the UxTXREG register. To ensure the Start bit detection, it is recommended to have a delay between enabling the UARTx (UARTEN = 1) and initiating the first transmission. The delay is baud rate dependent and should be equal to or longer than the time it takes to transmit one data bit.

Figure 17-4: UART Transmission

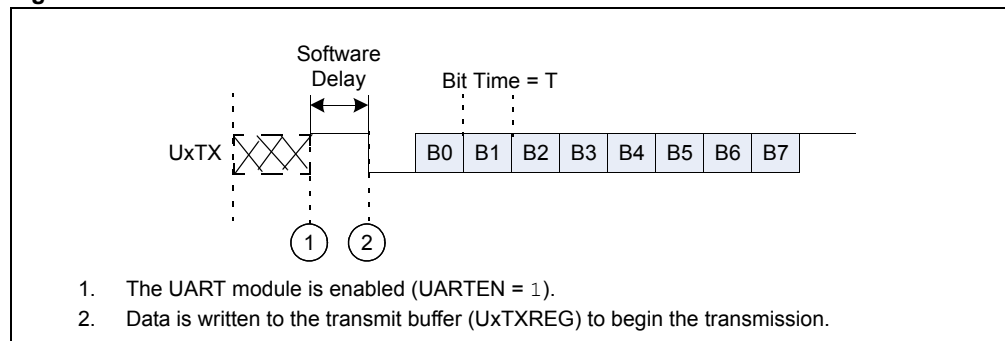

17.5.1 Transmit Buffer (UxTXREG)

The transmit buffer is 9-bit wide and 4 levels deep. Together with the Transmit Shift register (UxTSR), the user effectively has a 5-level deep buffer. It is organized as a First-In-First-Out (FIFO). Once the UxTXREG contents are transferred to the UxTSR register, the current buffer location becomes available for new data to be written and the next buffer location is sourced to the UxTSR register. The UTXBF (UxSTA<9>) status bit is set whenever the buffer is full. If a user application write to a full buffer, the new data will not be accepted into the FIFO.

The FIFO is reset during any device Reset, but it is not affected when the device enters a power-saving mode or wakes up from a power-saving mode.

17.5.2 Transmit Interrupt

The Transmit Interrupt Flag (UxTXIF) is located in the corresponding Interrupt Flag Status register (IFS). The UTXISEL<1:0> control bits (UxSTA<15,13>) determine when the UART will generate a transmit interrupt.

- If UTXISEL<1:0> = 00, the UxTXIF is set when a character is transferred from the transmit buffer to the Transmit Shift register (UxTSR). This implies that at least one location is empty in the transmit buffer.
- If UTXISEL<1:0> = 01, the UxTXIF is set when the last character is shifted out of the UxTSR register. This implies that all the transmit operations are completed.
- If UTXISEL<1:0> = 10, the UxTXIF is set when the character is transferred to the UxTSR register and the transmit buffer is empty.

The UxTXIF bit is set when the module is enabled. The user-assigned application should clear the UxTXIF bit in the Interrupt Service Routine (ISR).

Switching between the two interrupt modes during operation is possible.

Note: When the UTXEN bit is set, the UxTXIF flag bit will also be set if UTXISEL<1:0> = 00, because the transmit buffer is not full (can move transmit data to the UxTXREG register).

While the UxTXIF flag bit indicates the status of the UxTXREG register, the TRMT bit (UxSTA<8>) indicates the status of the UxTSR. The TRMT status bit is a read-only bit, which is set when the UxTSR is empty. No interrupt logic is tied to this bit, because the user application has to poll this bit to determine if the UxTSR is empty.

17.5.3 Setup for UART Transmit

Use the following steps to set up a transmission:

1. Initialize the UxBRG register for the appropriate Baud rate (see 17.3 “UART Baud Rate Generator”).
2. Set the number of data bits, number of Stop bits, and parity selection by writing to the PDSEL<1:0> (UxMODE<2:1>) and STSEL (UxMODE<0>) bits.
3. If transmit interrupts are required, set the UxTXIE control bit in the corresponding Interrupt Enable Control register (IEC).
 - Select the Transmit Interrupt mode by writing the UTXISEL<1:0> (UxSTA<15,13>) bits.
 - Specify the interrupt priority for the transmit interrupt using the UxTXIP<2:0> control bits in the corresponding Interrupt Priority Control register (IPC).
4. Enable the UART module by setting the UARTEN bit (UxMODE<15>).
5. Enable the transmission by setting the UTXEN bit (UxSTA<10>), which will also set the UxTXIF bit.

The UxTXIF bit should be cleared in the software routine that services the UART transmit interrupt. The operation of the UxTXIF bit is controlled by the UTXISEL<1:0> control bits.

6. Load data into the UxTXREG register (starts transmission).

If 9-bit transmission is selected, load a word. If 8-bit transmission is used, load a byte. Data can be loaded into the buffer until the UTXBF status bit (UxSTA<9>) is set.

Note: The UTXEN bit should not be set until the UARTEN bit has been set; otherwise, UART transmissions will not be enabled.

Example 17-2 provides sample code that sets up the UART for transmission.

Figure 17-5: Transmission (8-bit or 9-bit Data)

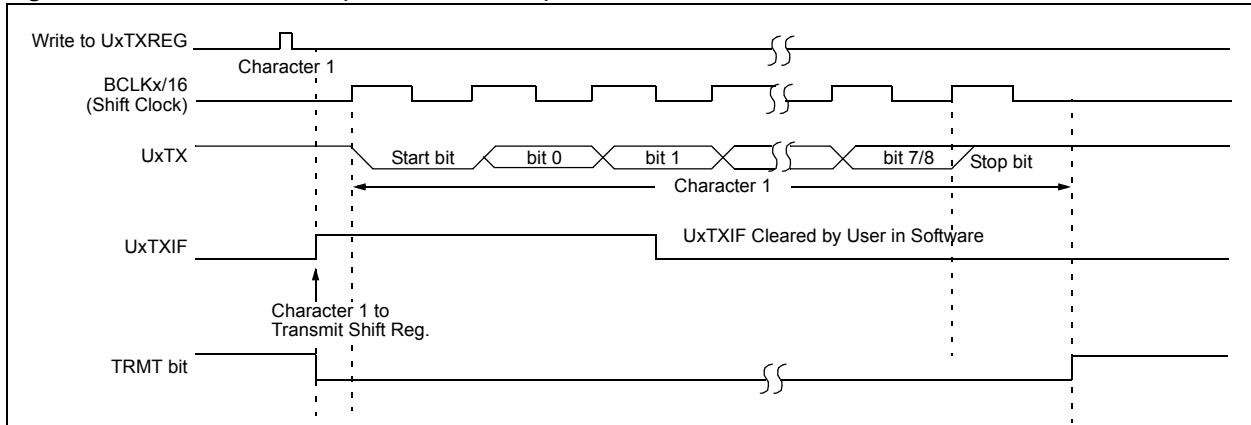
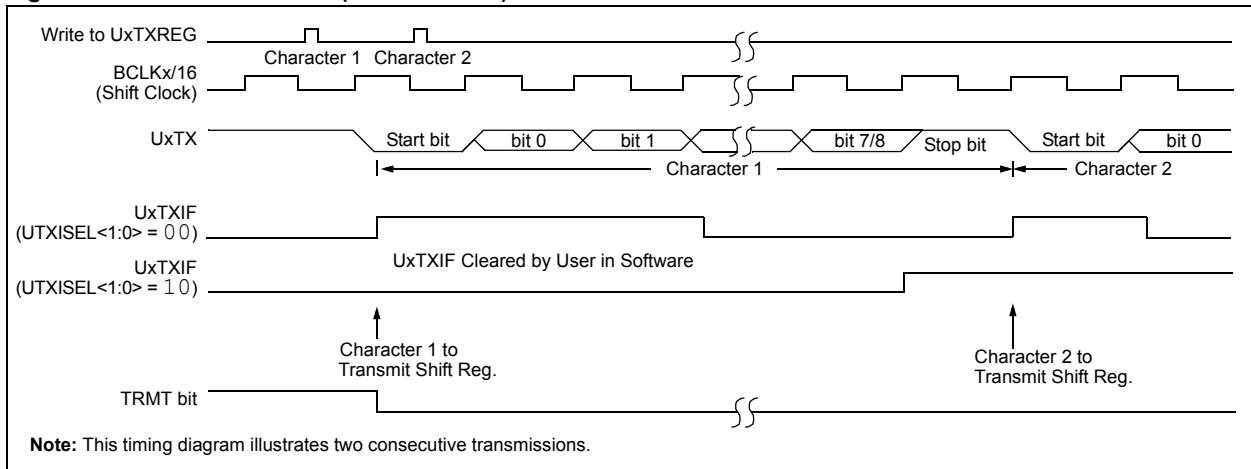

Figure 17-6: Transmission (Back-to-Back)



Note: This timing diagram illustrates two consecutive transmissions.

dsPIC33F/PIC24H Family Reference Manual

Example 17-2: UART Transmission with Interrupts

```
#define FCY 40000000
#define BAUDRATE 9600
#define BRGVAL ((FCY/BAUDRATE)/16)-1
unsigned int i;

int main(void)
{
    // Configure Oscillator to operate the device at 40 MHz
    // Fosc = Fin * M/(N1 * N2), Fcy = Fosc/2
    // Fosc = 8M * 40(2 * 2) = 80 MHz for 8M input clock
    PLLFBD = 38; // M = 40
    CLKDIVbits.PLLPOST = 0;           // N1 = 2
    CLKDIVbits.PLLPRE = 0;           // N2 = 2
    OSCTUN = 0;                       // Tune FRC oscillator, if FRC is used
    RCONbits.SWDTEN = 0;              // Disable Watch Dog Timer

    while(OSCCONbits.LOCK! = 1) {};    // Wait for PLL to lock

    U1MODEbits.STSEL = 0;              // 1 Stop bit
    U1MODEbits.PDSEL = 0;              // No Parity, 8 data bits
    U1MODEbits.ABAUD = 0;              // Auto-Baud Disabled
    U1MODEbits.BRGH = 0;              // Low Speed mode

    U1BRG = BRGVAL;                   // BAUD Rate Setting for 9600

    U1STAbits.UTXISEL0 = 0;           // Interrupt after one TX Character is transmitted
    U1STAbits.UTXISEL1 = 0;

    IEC0bits.U1TXIE = 1;              // Enable UART TX Interrupt

    U1MODEbits.UARTEN = 1;            // Enable UART
    U1STAbits.UTXEN = 1;              // Enable UART TX

    /* wait at least 104 usec (1/9600) before sending first char */
    for(i = 0; i < 4160; i++)
    {
        Nop();
    }

    U1TXREG = 'a';                    // Transmit one character

    while(1)
    {
    }
}

void __attribute__((__interrupt__)) _U1TXInterrupt(void)
{
    IFS0bits.U1TXIF = 0;              // clear TX interrupt flag
    U1TXREG = 'a';                    // Transmit one character
}
```

17.5.4 Transmission of Break Characters

A Break character transmit consists of a Start bit, followed by twelve bits of '0' and a Stop bit. A Frame Break character is sent whenever the UTXBRK and UTXEN bits are set when the Transmit Shift register is loaded with data. A dummy write to the UxTXREG register is necessary to initiate the Break character transmission. The data value written to the UxTXREG register for the Break character is ignored. The write serves the purpose of initiating the proper sequence: all '0's will be transmitted.

The UTXBRK bit is reset by hardware after the corresponding Stop bit is sent. This allows the user-assigned application to preload the transmit FIFO with the next transmit byte following the Break character (typically, the Sync character in the LIN specification).

Note: The user-assigned application should wait for the transmitter to be Idle ($TRMT = 1$) before setting the UTXBRK bit. The UTXBRK bit overrides any other transmitter activity. If the user application clears the TXBRK bit prior to sequence completion, unexpected module behavior can result. Sending a Break character does not generate a transmit interrupt.

The TRMT bit indicates when the Transmit Shift register is empty or full, similar to the normal transmission. See Figure 17-7 for the timing of the Break character sequence.

Figure 17-7: Send Break Character Sequence

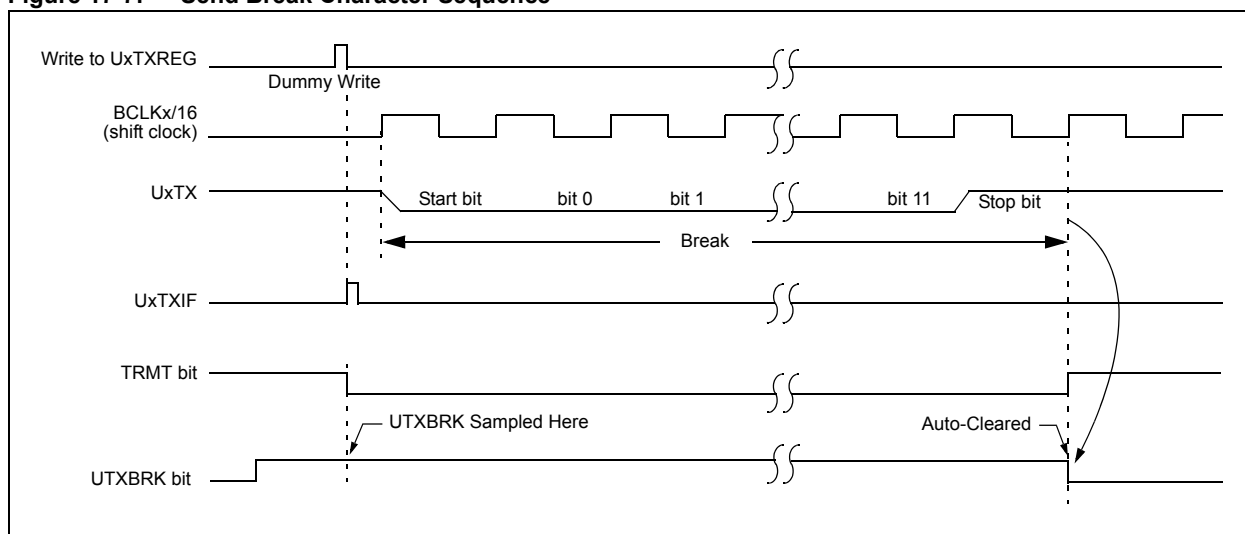

17.5.4.1 BREAK AND SYNC TRANSMIT SEQUENCE

The following sequence will send a message frame header made up of a Break followed by an auto-baud Sync byte. This sequence is typical of a LIN bus master.

1. Configure the UART for the desired mode.
2. Set UTXEN and UTXBRK to transmit the Break character.
3. Load the UxTXREG with a dummy character to initiate transmission (value is ignored).
4. Write 0x55 to UxTXREG, which loads the Sync character into the transmit FIFO.

After the Break is sent, the UTXBRK bit is reset by hardware and the Sync character is transmitted.

17.6 DATA BIT DETECTION

17.6.1 16x Clock Mode (BRGH = 0)

In 16x Clock mode, each bit of the received data is 16-clock-pulses wide. To detect the value of an incoming data bit, the bit is sampled at 7th, 8th, and 9th rising edges of the clock. These rising edges are called Majority Detection Edges. This mode is more robust than 4x Clock mode.

Figure 17-8: 16x Clock Mode with Majority Detection

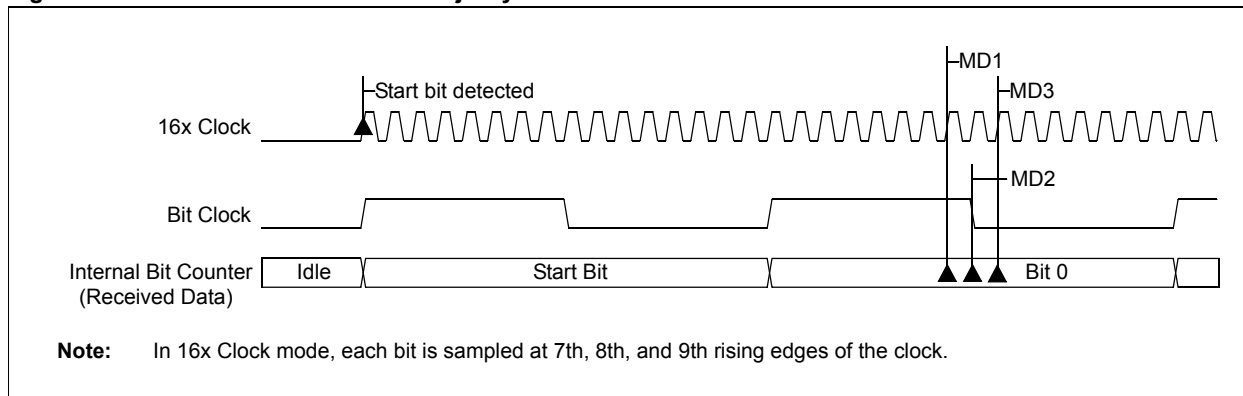

17.6.2 4x Clock Mode (BRGH = 1)

In 4x Clock mode, each bit of the received data is 4-clock-pulses wide. The 4x Clock mode does not provide enough edges to support the Majority Detection Method. Therefore, the received data is sampled at the one-half bit width.

Figure 17-9: 4x Clock Mode Without Majority Detection

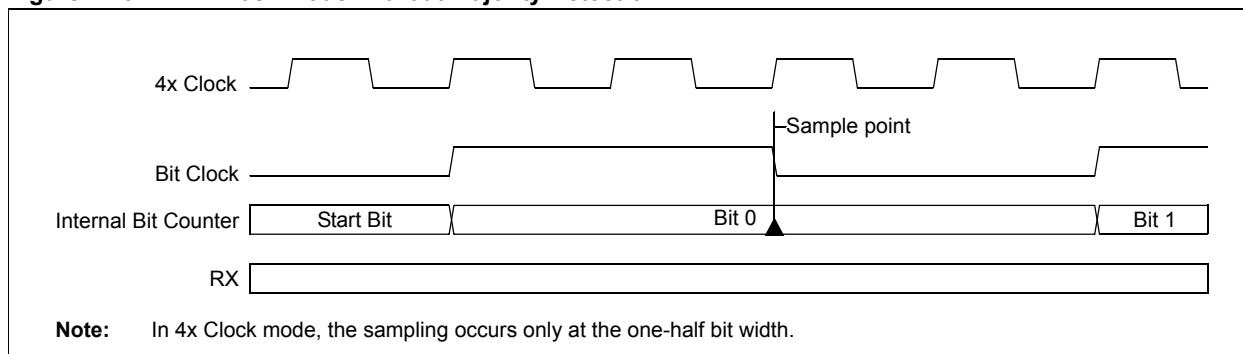

17.7 UART RECEIVER

The block diagram of the receiver is illustrated in Figure 17-10. The heart of the receiver is the Receive (Serial) Shift (UxRSR) register. The data is received on the UxRX pin and is sent to the data recovery block. The data recovery block operates at 16 times the Baud rate, whereas the main receive serial shifter operates at the Baud rate. After sampling the UxRX pin for the Stop bit, the received data in UxRSR is transferred to the receive FIFO (if it is empty).

Note: The UxRSR register is not mapped in data memory, so it is not available to the user-assigned application.

The data on the UxRX pin is sampled multiple times by a majority detect circuit to determine whether a high or a low level is present at the UxRX pin.

17.7.1 Receive Buffer (UxRXREG)

The UART receiver has a 4-deep, 9 bit wide FIFO receive data buffer. UxRXREG is a memory mapped register that provides access to the output of the FIFO. It is possible for four words of data to be received and transferred to the FIFO and a fifth word to begin shifting to the UxRSR register before a buffer overrun occurs.

17.7.2 Receiver Error Handling

If the FIFO is full (four characters) and a fifth character is fully received into the UxRSR register, the Overrun Error OERR bit (UxSTA<1>) will be set. The word in UxRSR will be kept, but further transfers to the receive FIFO are inhibited as long as the OERR bit is set. The user application must clear the OERR bit in software to allow further data to be received.

If it is essential to keep the data received prior to the overrun, the user application must read all five characters and then clear the OERR bit. If the five characters can be discarded, the user application can clear the OERR bit. This effectively resets the receive FIFO, and all prior received data is lost.

Note: The data in the receive FIFO should be read prior to clearing the OERR bit. The FIFO is reset when OERR is cleared, which causes all data in the buffer to be lost.

The Framing Error bit, FERR (UxSTA<2>), is set if a Stop bit is detected at a logic low level.

The Parity Error bit, PERR (UxSTA<3>), is set if a parity error is detected in the data word at the top of the buffer (that is, the current word). For example, a parity error occurs if the parity is set to be Even, but the total number of '1's in the data is detected to be Odd. The PERR bit is irrelevant in the 9-bit mode. The FERR and PERR bits are buffered along with the corresponding word and should be read before reading the data word.

An interrupt is generated if any of these (OERR, FERR and PERR) errors occur. The user application needs to enable the corresponding Interrupt Enable Control bit (IEC4<UxERIE>) to go to the corresponding interrupt vector location.

17.7.3 Receive Interrupt

The UART Receive Interrupt Flag (UxRXIF) is located in the corresponding Interrupt Flag Status register (IFS). The URXISEL<1:0> (UxSTA<7:6>) control bits determine when the UART receiver generates an interrupt.

- If URXISEL<1:0> = 00 or 01, an interrupt is generated each time a data word is transferred from the Receive Shift (UxRSR) register to the receive buffer. There may be one or more characters in the receive buffer.
- If URXISEL<1:0> = 10, an interrupt is generated when a word is transferred from the UxRSR register to the receive buffer, and as a result, the receive buffer contains 3 or 4 characters.
- If URXISEL<1:0> = 11, an interrupt is generated when a word is transferred from the UxRSR register to the receive buffer, and as a result, the receive buffer contains 4 characters (that is, becomes full).

Switching between the three Interrupt modes during operation is possible.

dsPIC33F/PIC24H Family Reference Manual

While the URXDA and UxRXIF flag bits indicate the status of the UxRXREG register, the RIDLE bit (UxSTA<4>) shows the status of the UxRSR register. The RIDLE status bit is a read-only bit, which is set when the receiver is in Idle mode (that is, the UxRSR register is empty). No interrupt logic is tied to this bit, because the user application must poll this bit to determine whether the UxRSR is Idle.

The URXDA bit (UxSTA<0>) indicates whether the receive buffer has data or is empty. This bit is set as long as there is at least one character to be read from the receive buffer. URXDA is a read-only bit.

Figure 17-10 illustrates a block diagram of the UART receiver.

Figure 17-10: UART Receiver Block Diagram

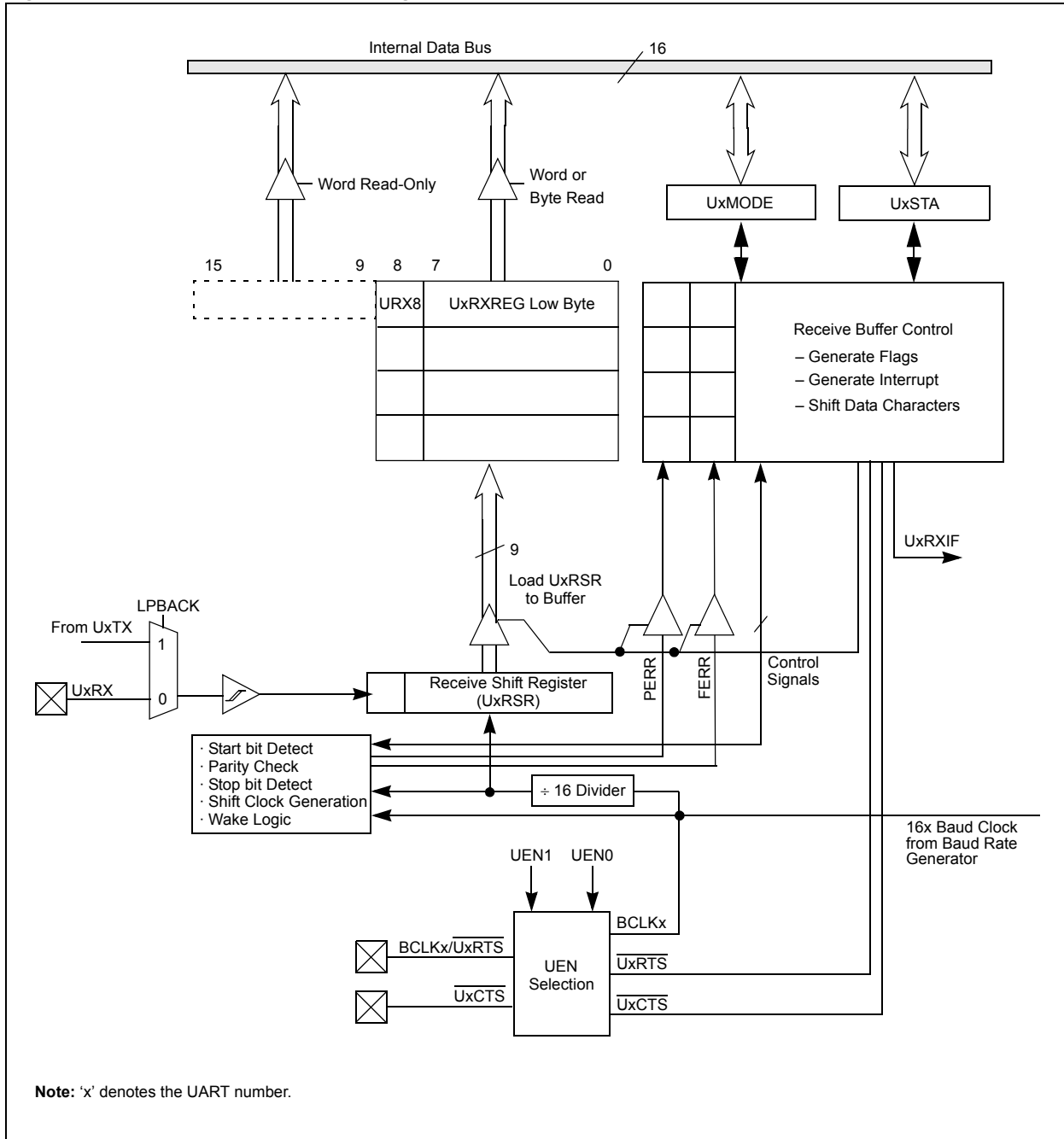

17.7.4 Setup for UART Reception

Use the following steps to set up a reception:

1. Initialize the UxBRG register for the appropriate baud rate (see 17.3 “UART Baud Rate Generator”).
2. Set the number of data bits, Stop bits, and parity selection by writing to the PDSEL<1:0> bit (UxMODE<2:1>) and STSEL bit (UxMODE<0>).
3. If interrupts are desired, set the UxRXIE bit in the corresponding Interrupt Enable Control register (IEC).
 - Select the Receive Interrupt mode by writing the URXISEL<1:0> bit (UxSTA<7:6>).
 - Specify the interrupt priority for the interrupt using the UxRXIP<2:0> control bits in the corresponding Interrupt Priority Control register (IPC).
4. Enable the UART module by setting the UARTEN bit (UxMODE<15>).
5. Receive interrupts will depend on the URXISEL<1:0> control bit settings.

If receive interrupts are not enabled, the user application can poll the URXDA bit. The UxRXIF bit should be cleared in the software routine that services the UART receive interrupt.

6. Read data from the receive buffer.

If 9-bit transmission is selected, read a word or read a byte. The URXDA status bit (UxSTA<0>) is set whenever data is available in the buffer.

Example 17-3 provides sample code that sets up the UART for reception.

Figure 17-11: UART Reception

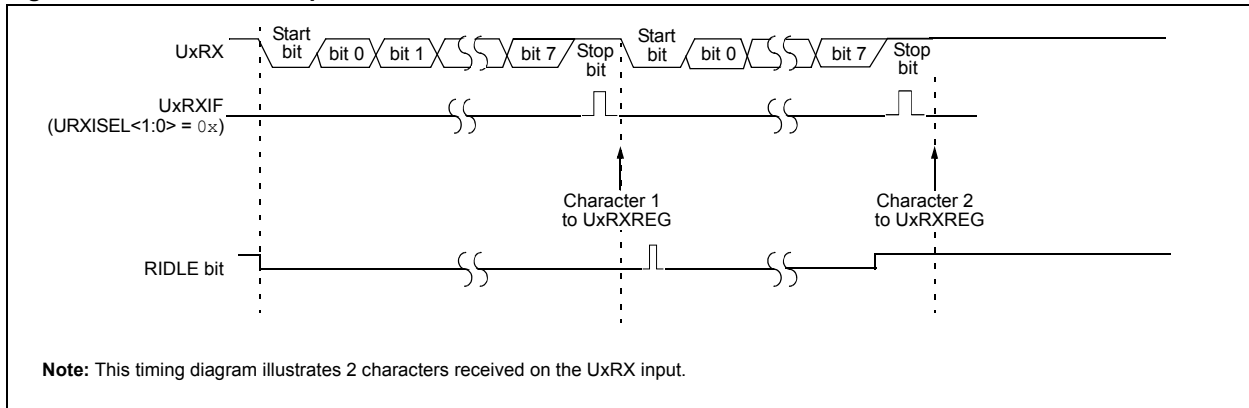

Note: If the interrupt flag is used by the application software as a basis for disabling the UART transmission, the software should wait for 1 bit time before disabling the transmission.

Figure 17-12: UART Reception with Receive Overrun

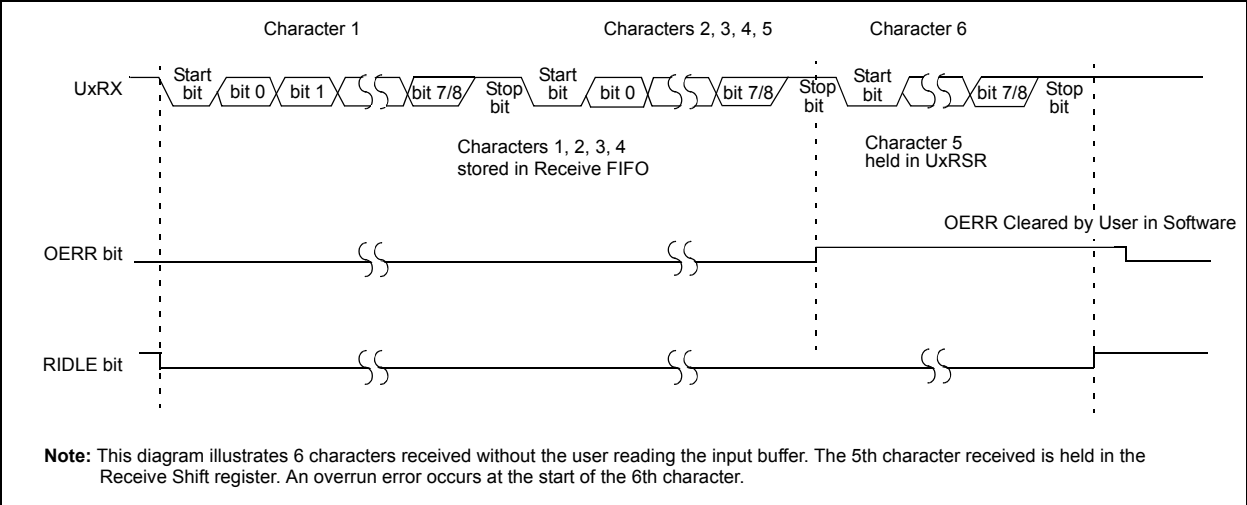

Example 17-3: UART Receiving with Polling (Interrupts Disabled)

```

#define FCY 4000000
#define BAUDRATE 9600
#define BRGVAL ((FCY/BAUDRATE)/16) - 1

int main(void)
{

// Configure Oscillator to operate the device at 40 MHz
// Fosc = Fin * M/(N1 * N2), Fcy = Fosc/2
// Fosc = 8M * 40(2 * 2) = 80 MHz for 8M input clock
  PLLFBD = 38; // M = 40
  CLKDIVbits.PLLPOST = 0;           // N1 = 2
  CLKDIVbits.PLLPRE = 0;           // N2 = 2
  OSCTUN = 0;                       // Tune FRC oscillator, if FRC is used

  RCONbits.SWDTEN = 0;              // Disable Watch Dog Timer

  while(OSCCONbits.LOCK! = 1) {};    // Wait for PLL to lock

  U1MODEbits.STSEL = 0;              // 1 Stop bit
  U1MODEbits.PDSEL = 0;              // No Parity, 8 data bits
  U1MODEbits.ABAUD = 0;              // Auto-Baud Disabled
  U1MODEbits.BRGH = 0;               // Low-Speed mode

  U1BRG = BRGVAL;                    // BAUD Rate Setting for 9600

  U1STAbits.URXISEL = 0;             // Interrupt after one RX character is received;

  U1MODEbits.UARTEN = 1;            // Enable UART

  while(1)
  {
    char ReceivedChar;

    /* check for receive errors */
    if(U1STAbits.FERR = 1)
    {
      continue;
    }

    /* must clear the overrun error to keep uart receiving */
    if(U1STAbits.OERR = 1)
    {
      U1STAbits.OERR = 0;
      continue;
    }

    /* get the data */
    if(U1STAbits.URXDA = 1)
    {
      ReceivedChar = U1RXREG;
    }
  }
}

```

17.8 USING THE UART FOR 9-BIT COMMUNICATION

The UART receiver can be used in 9-bit Data mode for multiprocessor communication. With the ADDEN bit set in 9-bit Data mode, the receiver can ignore the data when the 9th bit of the data is '0'. This feature can be used in a multiprocessor environment.

17.8.1 Multiprocessor Communications

A typical multiprocessor communication protocol differentiates between data bytes and address/control bytes. A common scheme is to use a 9th data bit to identify whether a data byte is address or data information. If the 9th bit is set, the data is processed as address or control information. If the 9th bit is cleared, the received data word is processed as data associated with the previous address/control byte.

The protocol operates as follows:

- The master device transmits a data word with the 9th bit set. The data word contains the address of a slave device.
- All slave devices in the communication chain receive the address word and check the slave address value.
- The slave device that was addressed will receive and process subsequent data bytes sent by the master device. All other slave devices will discard subsequent data bytes until a new address word (9th bit set) is received.

17.8.2 ADDEN Control Bit

The UART receiver has an Address Detect mode, which allows it to ignore data words with the 9th bit cleared. This reduces the interrupt overhead, because data words with the 9th bit cleared are not buffered. This feature is enabled by setting the ADDEN bit (UxSTA<5>).

The UART must be configured for 9-bit Data mode to use the Address Detect mode. The ADDEN bit has no effect when the receiver is configured in 8-bit Data mode.

17.8.3 Setup for 9-bit Transmit

The setup procedure for 9-bit transmission is identical to the procedure for 8-bit Transmit modes, except that the PDSEL<1:0> bits (UxMODE<2:1>) should be set to '11' (see **17.5.3 “Setup for UART Transmit”**).

Word writes should be performed to the UxTXREG register (starts transmission).

17.8.4 Setup for 9-bit Reception Using Address Detect Mode

The setup procedure for 9-bit reception is similar to the procedure for 8-bit Receive modes, except that the PDSEL<1:0> bits (UxMODE<2:1>) should be set to '11' (see 17.7.4 "Setup for UART Reception").

The Receive Interrupt mode should be configured by writing to the URXISEL<1:0> and (UxSTA<7:6>) bits.

Note: If the Address Detect mode is enabled (ADDEN = 1), the URXISEL<1:0> control bits should be configured so that an interrupt will be generated after every received word. Each received data word must be checked in the software for an address match immediately after the reception.

The procedure for using the Address Detect mode is as follows:

1. Set the ADDEN bit (UxSTA<5>) to enable address detect. Ensure that the URXISEL control bits are configured to generate an interrupt after each received word.
2. Check each 8-bit address by reading the UxRXREG register to determine if the device is being addressed.
3. If this device is not addressed, discard the received word.
4. If this device is addressed, clear the ADDEN bit to allow subsequent data bytes to be read into the receive buffer and interrupt the CPU.

If a long data packet is expected, the Receive Interrupt mode can be changed to buffer more than one data byte between interrupts.

5. When the last data byte is received, set the ADDEN bit, so that only address bytes will be received.

Also, ensure that the URXISEL control bits are configured to generate an interrupt after each received word.

Figure 17-13: Reception with Address Detect (ADDEN = 1)

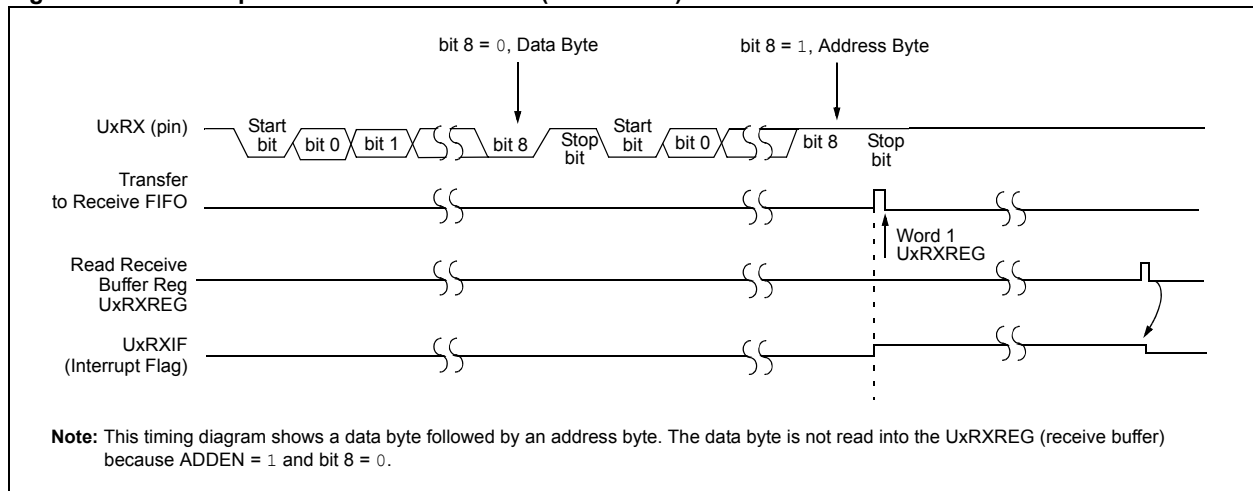

17.9 OTHER FEATURES OF THE UART

17.9.1 UART in Loopback Mode

Setting the LPBACK bit enables the Loopback mode, in which the UxTX output is internally connected to the UxRX input. When configured for the Loopback mode, the UxRX pin is disconnected from the internal UART receive logic. However, the UxTX pin still functions normally.

To select the Loopback mode, perform the following action:

1. Configure UART for the desired mode of operation.
2. Enable transmission as defined in **17.5 “UART Transmitter”**.
3. Set LPBACK = 1 (UxMODE<6>) to enable Loopback mode.

The Loopback mode is dependent on the UEN<1:0> bits, as listed in Table 17-1.

Table 17-1: Loopback Mode Pin Function

UEN<1:0>	Pin Function, LPBACK = 1 ⁽¹⁾
00	UxRX input connected to UxTX; UxTX pin functions; UxRX pin ignored; UxCTS/UxRTS unused
01	UxRX input connected to UxTX; UxTX pin functions; UxRX pin ignored; UxRTS pin functions; UxCTS unused
10	UxRX input connected to UxTX; UxTX pin functions; UxRX pin ignored; UxRTS pin functions; UxCTS input connected to UxRTS; UxCTS pin ignored
11	UxRX input connected to UxTX; UxTX pin functions; UxRX pin ignored; BCLKx pin functions; UxCTS/UxRTS unused

Note 1: The LPBACK bit should be set to ‘1’ only after enabling the other bits associated with the UART module.

17.9.2 Auto-Baud Support

To allow the system to determine baud rates of the received characters, the ABAUD bit is enabled. The UART will begin an automatic baud rate measurement sequence whenever a Start bit is received while the Auto-Baud Rate Detect is enabled (ABAUD = 1). The calculation is self-averaging. After the ABAUD bit is set, the BRG counter value will be cleared and will look for a Start bit, which is defined as a high-to-low transition followed by a low-to-high transition.

Following the Start bit, the auto-baud expects to receive an ASCII “U” (55h or 0x55) to calculate the bit rate. The measurement is taken over both the low and the high bit time to minimize any effects caused by asymmetry of the incoming signal. On the 5th UxRX pin rising edge, an accumulated BRG counter value totalling the proper BRG period is transferred to the UxBRG register. The ABAUD bit is automatically cleared. If the user application clears the ABAUD bit prior to sequence completion, unexpected module behavior can result. See Figure 17-14 for the Auto-Baud Rate Detection sequence.

Figure 17-14: Auto-Baud Rate Calculation

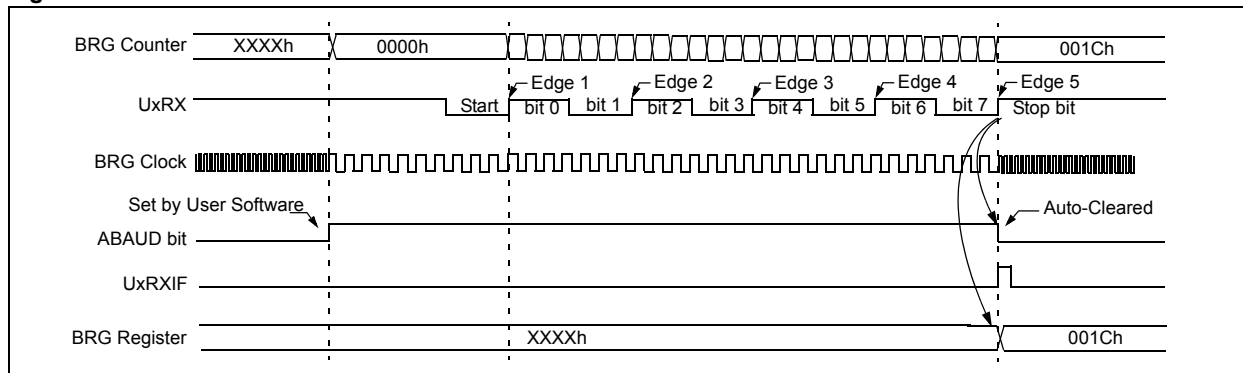

While the Auto-Baud sequence is in progress, the UART state machine is held in the Idle state. The UxRXIF interrupt is set on the 5th UxRX rising edge, independent of the URXISEL<1:0> settings. The receiver FIFO is not updated.

17.10 UART OPERATION WITH DMA

On some dsPIC33F/24H devices, the Direct Memory Access (DMA) module can be used to transfer data between the CPU and UART without CPU assistance. Refer to the dsPIC33F/24H device data sheet to see if DMA is available on your device. For more information on the DMA module, refer to the **Section 22. “Direct Memory Access (DMA)”** (DS701832) in the “dsPIC33F Family Reference Manual”.

17.10.1 UART Receive with DMA

If the DMA channel is associated with the UART receiver, the UART should issue a DMA request every time a character is ready to be moved from UART to RAM. DMA will transfer data from the UxRXREG register into RAM and issue a CPU interrupt after a predefined number of transfers. Because DMA channels are unidirectional, the UART receive operation would require one DMA channel. The DMA Channel for UART reception should be configured as listed in Table 17-2

Table 17-2: DMA Channel Register Initialization for UART to DMA Association (UART Reception)

Peripheral to DMA Association	DMAxREQ Register IRQSEL<6:0> Bits	DMAxPAD Register Values to Read From Peripheral
UART1RX – UART1 Receiver	0001011	0x0226 (U1RXREG)
UART2RX – UART2 Receiver	0011110	0x0236 (U2RXREG)

The UART must be configured to generate interrupts for every character received. For the UART receiver to generate an Rx interrupt for each character received, the Receive Interrupt Mode Selection bits (URXISEL<1:0>) must be set to ‘00’ or ‘01’ in the Status and Control (UxSTA) register. When the UART and DMA channels are configured, the UART receiver issues a DMA request as soon as data is received. No special steps needs to be taken by the user-assigned application to initiate a DMA transfer.

While configuring UART reception, the DMA channel word size should be set to 16-bit. This configures the DMA channel to read 16-bit from the UART module when data is available to be read. The lower byte of the data represents the actual data byte received by the UART module. The upper byte of the transferred contains the UART status when the byte was received. The reading of the UxSTA register, when the UART reception is DMA enabled, will not return the status of the FERR and PERR. This status is available in the upper byte of the 16-bit word that the DMA channel transfers from the UART module to DMA RAM. Table 17-15 illustrates the organization of the 16-bit word that the DMA transfers from UART module to the DMA RAM.

Figure 17-15: Format of 16-Bit UART Receive Data Word Transferred by DMA to RAM

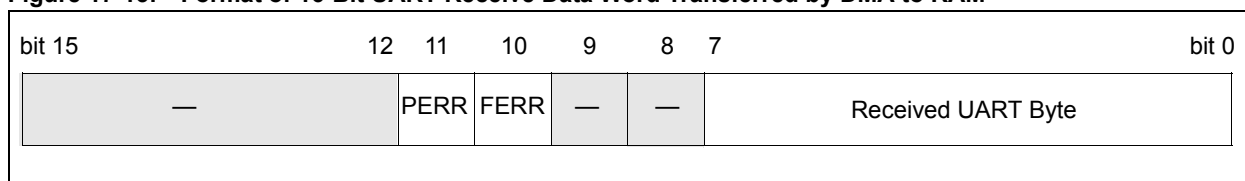

The DMAxPAD register should still point to the UxRXREG register. The UART Error Interrupt Flag (UxEIF) will be set if the last UART reception caused a framing or a parity error. Setting the UxEIE bit causes the CPU to enter the UART error interrupt service routine. The application can then inspect the upper byte of the last transferred word to check which error condition caused the interrupt.

17.10.2 UART Transmit with DMA

If the DMA channel is associated with the UART transmitter, the UART will issue a DMA request after each successful transmission. After each DMA request, the DMA transfers new data into the UxTXREG register and issues a CPU interrupt after a predefined number of transfers. Because the DMA channels are unidirectional, one DMA channel is required for transmit. Each DMA channel must be initialized as listed in Table 17-3:

Table 17-3: DMA Channel Register Initialization for UART to DMA Association (UART Reception)

Peripheral to DMA Association	DMAxREQ Register IRQSEL<6:0> Bits	DMAxPAD Register Values to Write from Peripheral
UART1TX – UART1 Transmitter	0001100	0x0224 (U1TXREG)
UART2TX – UART2 Transmitter	0011111	0x0234 (U2TXREG)

In addition, the UART must be configured to generate interrupts for every character transmitted. For the UART transmitter to generate a Tx interrupt for each character transmitted, the Transmission Interrupt Mode Selection bits (UTXISEL0 and UTXISEL1) must be set to '0' in the UxSTA register.

The UART transmitter issues a DMA request as soon as the UART and transmitter is enabled. This means that the DMA channel and buffers must be initialized and enabled before the UART and transmitter. Alternatively, the UART and UART transmitter can be enabled before the DMA channel is enabled. In this case, the UART transmitter DMA request will be lost, and the user-assigned application must issue a DMA request to start DMA transfers by setting the FORCE bit in the DMAxREQ register.

17.10.3 UART DMA Configuration Example

Example 17-4 provides sample code for the UART reception and transmission with the help of two DMA channels. The UART receives and buffers characters from the HyperTerminal at 9600 bps. After 8 characters are received, the UART transmits (echoes) them back to the HyperTerminal.

DMA Channel 0 is configured for UART transmission with the following configuration:

- Transfer data from RAM to UART
- One-Shot mode
- Register Indirect with Post-Increment
- Using single buffer
- Eight transfers per buffer
- Transfer words

DMA Channel 1 is configured for UART reception with the following configuration:

- Transfer data from UART to RAM Continuously
- Register Indirect with Post-Increment
- Using two Ping-Pong buffers
- Eight transfers per buffer
- Transfer words

Example 17-4: UART Reception and Transmission with DMA**Set Up UART for RX and TX:**

```

#define FCY 40000000
#define BAUDRATE 9600
#define BRGVAL ((FCY/BAUDRATE)/16) - 1

U2MODEbits.STSEL = 0;           // 1 Stop bit
U2MODEbits.PDSEL = 0;          // No Parity, 8 data bits
U2MODEbits.ABAUD = 0;          // Auto-Baud Disabled

U2BRG = BRGVAL; // BAUD Rate Setting for 9600

U2STAbits.UTXISEL0 = 0;        // Interrupt after one TX character is transmitted
U2STAbits.UTXISEL1 = 0;
U2STAbits.URXISEL = 0;        // Interrupt after one RX character is received

U2MODEbits.UARTEN = 1;         // Enable UART
U2STAbits.UTXEN = 1;          // Enable UART TX

-U2EIF = 0;                    // Clear UART2 error interrupt Flag
-U2EIE = 1;                    // Enable UART2 error interrupt

```

Set Up DMA Channel 0 to Transmit in One-Shot, Single-Buffer Mode:

```

unsigned int BufferA[8] __attribute__((space(dma)));
unsigned int BufferB[8] __attribute__((space(dma)));

DMA0CON = 0x2001;              // One-Shot, Post-Increment, RAM-to-Peripheral
DMA0CNT = 7;                  // 8 DMA requests
DMA0REQ = 0x001F;             // Select UART2 Transmitter

DMA0PAD = (volatile unsigned int) &U2TXREG;
DMA0STA = __builtin_dmaoffset(BufferA);

IFS0bits.DMA0IF = 0;          // Clear DMA Interrupt Flag
IEC0bits.DMA0IE = 1;          // Enable DMA Interrupt

```

Set Up DMA Channel 1 to Receive in Continuous Ping-Pong Mode:

```

DMA1CON = 0x0002;             // Continuous, Ping-Pong, Post-Inc., Periph-RAM
DMA1CNT = 7;                  // 8 DMA requests
DMA1REQ = 0x001E;            // Select UART2 Receiver

DMA1PAD = (volatile unsigned int) &U2RXREG;
DMA1STA = __builtin_dmaoffset(BufferA);
DMA1STB = __builtin_dmaoffset(BufferB);

IFS0bits.DMA1IF = 0;          // Clear DMA interrupt
IEC0bits.DMA1IE = 1;          // Enable DMA interrupt
DMA1CONbits.CHEN = 1;         // Enable DMA Channel

void __attribute__((__interrupt__,no_auto_psv)) _U2EInterrupt(void)
{
    // An error has occurred on the last
    // reception. Check the last received
    // word.

    _U2EIF = 0;

    int lastWord;

```

Example 17-4: UART Reception and Transmission with DMA (Continued)

```
// Check which DMA Ping pong channel
// was selected.

if(DMACS1bits.PPST1 == 0)
{
    // Get the last word received from ping pong buffer A.
    lastWord = *(unsigned int *)((unsigned int)(BufferA) + DMA1STA);
}
else
{
    // Get the last word received from ping pong buffer B.
    lastWord = *(unsigned int *)((unsigned int)(BufferB) + DMA1STB);
}

//Check for Parity Error

if((lastWord & 0x800) != 0)
{
    // There was a parity error
    // Do something about it here.
}

// Check for framing error
if ((lastWord & 0x400) != 0)
{
    // There was a framing error
    // Do some thing about it here.
}
}
```

Set Up DMA Interrupt Handlers:

```
void __attribute__((__interrupt__)) _DMA0Interrupt(void)
{
    IFS0bits.DMA0IF = 0; // Clear the DMA0 Interrupt Flag;
}

void __attribute__((__interrupt__)) _DMA1Interrupt(void)
{
    static unsigned int BufferCount = 0; // Keep record of which buffer contains RX Data

    if(BufferCount == 0)
    {
        DMA0STA = __builtin_dmaoffset(BufferA); // Point DMA 0 to data
                                                // to be transmitted
    }
    else
    {
        DMA0STA = __builtin_dmaoffset(BufferB); // Point DMA 0 to data
                                                // to be transmitted
    }

    DMA0CONbits.CHEN = 1; // Enable DMA0 Channel
    DMA0REQbits.FORCE = 1; // Manual mode: Kick-start the 1st transfer

    BufferCount ^= 1;
    IFS0bits.DMA1IF = 0; // Clear the DMA1 Interrupt Flag}
}
```

17.11 UART OPERATION DURING CPU SLEEP AND IDLE MODES

17.11.1 UART Operation in Sleep Mode

When the device enters Sleep mode, all clock sources supplied to the UART module are shut down and stay at logic '0'. If the device enters Sleep mode in the middle of a UART transmission or reception operation, the operation is aborted and the UART pins (BCLKx, UxRTS, and UxTX) are driven to the default state.

A Start bit, when detected on the UART Receive (UxRX) pin, can wake up the device from Sleep mode if the WAKE bit (UxMODE<7>) is set before the device enters Sleep mode. In Sleep mode, if the UART receive interrupt (UxRXIE) is enabled, a falling edge on the UART Receive pin generates a UART receive interrupt (UxRXIF).

The receive interrupt wakes up the device from the Sleep mode the following actions takes place:

- If the assigned priority for the interrupt is less than or equal to the current CPU priority, the device wakes up and continues code execution from the instruction following the `PWRS` instruction that initiated Sleep mode.
- If the assigned priority level for the interrupt source is greater than the current CPU priority, the device wakes up and the CPU exception process starts. Code execution continues from the first instruction of the capture ISR.

The Wake bit is automatically cleared when a low-to-high transition is observed on the UxRX line following the wake-up event.

17.11.2 UART Operation in Idle Mode

When the device enters Idle mode, the system clock sources remain functional and the CPU stops code execution. The UART Stop-in Idle bit (USIDL) in the UART Mode register (UxMODE<13>) determines whether the module stops in Idle mode or continues to operate in Idle mode.

- If USIDL = 0 (UxMODE<13>), the module continues to operate in Idle mode and provides full functionality.
- If USIDL = 1 (UxMODE<13>), the module stops in Idle mode. The module performs the same functions when stopped in Idle mode as in Sleep mode (see 17.11.1 “UART Operation in Sleep Mode”).

- 1:** The Sync Break (or Wake-up Signal) character must be of sufficient length to allow enough time for the selected oscillator to start and provide initialization of the UART. To ensure that the UART woke up in time, the user application should read the value of the Wake bit. If Wake bit is clear, it is possible that the UART was not ready in time to receive the next character and the module might need to be resynchronized to the bus.
- 2:** In Sleep mode, when a Start bit detected, it causes the device to wake-up only if the Wake bit (UxMODE<7>) is set before the device enters Sleep mode.
- 3:** In Sleep and Idle mode, because a falling edge on the UART Receive pin generates a UART receive interrupt, a dummy byte is copied if the UART Receive buffer is read in the first UART Receive interrupt.

Figure 17-16: Auto Wake-up Bit (WAKE) Timings During Sleep

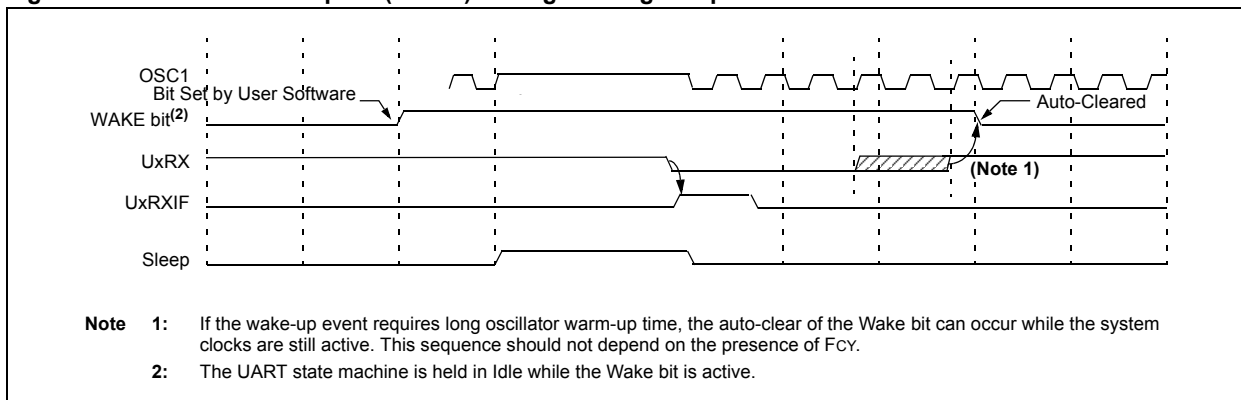

17.12 OPERATION OF $\overline{\text{UxCTS}}$ AND $\overline{\text{UxRTS}}$ CONTROL PINS

$\overline{\text{UxCTS}}$ (Clear to Send) and $\overline{\text{UxRTS}}$ (Request to Send) are the two hardware controlled pins associated with the UART module. These two pins allow the UART to operate in Flow Control and Simplex modes, which are explained in **17.12.2 “UxRTS Function in Flow Control Mode”** and **17.12.3 “UxRTS Function in Simplex Mode”**. They are implemented to control transmission and reception between the UART and Data Terminal Equipment (DTE).

17.12.1 $\overline{\text{UxCTS}}$ Function

In the UART operation, the $\overline{\text{UxCTS}}$ pin acts as an input, which can control the transmission. This pin is controlled by another device (typically a PC). The $\overline{\text{UxCTS}}$ pin is configured using $\text{UEN}\langle 1:0 \rangle$. When $\text{UEN}\langle 1:0 \rangle = 10$, the $\overline{\text{UxCTS}}$ pin is configured as an input. If $\overline{\text{UxCTS}} = 1$, the transmitter will load the data in the Transmit Shift register, but will not initiate a transmission. This will allow the DTE to control and receive data from the controller based on its requirements.

The $\overline{\text{UxCTS}}$ pin is sampled simultaneously when the transmit data changes (that is, at the beginning of the 16 Baud clocks). Transmission starts only when the $\overline{\text{UxCTS}}$ pin is sampled low. The $\overline{\text{UxCTS}}$ pin is sampled internally with a T_{CY} , which means that there should be a minimum pulse width of 1 T_{CY} on $\overline{\text{UxCTS}}$. However, this cannot be a specification because the T_{CY} can vary depending on the clock used.

The user application can also read the status of the $\overline{\text{UxCTS}}$ pin by reading the associated port pin.

17.12.2 $\overline{\text{UxRTS}}$ Function in Flow Control Mode

In the Flow Control mode, the $\overline{\text{UxRTS}}$ pin of the DTE is connected to the $\overline{\text{UxCTS}}$ pin of the dsPIC33F/PIC24H family and the $\overline{\text{UxCTS}}$ pin of the DTE is connected to the $\overline{\text{UxRTS}}$ pin of the dsPIC33F/PIC24H family, as shown in Figure 17-17. The $\overline{\text{UxRTS}}$ signal indicates the device is ready to receive the data. The $\overline{\text{UxRTS}}$ pin is driven as an output whenever $\text{UEN}\langle 1:0 \rangle = 01$ or 10 . The $\overline{\text{UxRTS}}$ pin is asserted (driven low) whenever the receiver is ready to receive data. When the RTSMD bit = 0 (when the device is in Flow Control mode), the $\overline{\text{UxRTS}}$ pin is driven low whenever the receive buffer is not full or the OERR bit is not set. When the RTSMD bit = 0, the $\overline{\text{UxRTS}}$ pin is driven high whenever the device is not ready to receive (that is, when the receiver buffer is either full or shifting).

Because the $\overline{\text{UxRTS}}$ pin of the data transmission equipment (DTE) is connected to the $\overline{\text{UxCTS}}$ pin of the dsPIC33F/PIC24H family, the $\overline{\text{UxRTS}}$ pin will drive the $\overline{\text{UxCTS}}$ pin low whenever it is ready to receive the data. Transmission of the data will start when the $\overline{\text{UxCTS}}$ pin goes low, as explained in **17.12.1 “UxCTS Function”**.

17.12.3 $\overline{\text{UxRTS}}$ Function in Simplex Mode

In the Simplex mode, the $\overline{\text{UxRTS}}$ pin of the data communication equipment (DCE) is connected to the $\overline{\text{UxRTS}}$ pin of the dsPIC33F/PIC24H family and the $\overline{\text{UxCTS}}$ pin of the DCE is connected to the $\overline{\text{UxCTS}}$ pin of the dsPIC33F/PIC24H family, as shown in Figure 17-18. In the Simplex mode, the $\overline{\text{UxRTS}}$ signal indicates that the DTE is ready to transmit. The DCE will reply to the $\overline{\text{UxRTS}}$ signal with the valid $\overline{\text{UxCTS}}$ signal whenever the DCE is ready to receive the transmission. When the DTE receives a valid $\overline{\text{UxCTS}}$ signal, it will begin transmission.

As shown in Figure 17-19, the Simplex mode is also used in IEEE-485 systems to enable transmitters. When the $\overline{\text{UxRTS}}$ signal indicates that the DTE is ready to transmit, the $\overline{\text{UxRTS}}$ signal will enable the driver.

The $\overline{\text{UxRTS}}$ pin is configured as an output and is driven whenever $\text{UEN}\langle 1:0 \rangle = 01$ or 10 . When $\text{RTSMD} = 1$, the $\overline{\text{UxRTS}}$ pin is asserted (driven low) whenever data is available to transmit ($\text{TRMT} = 0$). When $\text{RTSMD} = 1$, the $\overline{\text{UxRTS}}$ pin is deasserted (driven high) when the transmitter is empty ($\text{TRMT} = 1$).

dsPIC33F/PIC24H Family Reference Manual

Figure 17-17: $\overline{UxRTS}/\overline{UxCTS}$ Flow Control for DTE-DTE (RTSMD = 0, Flow Control Mode)

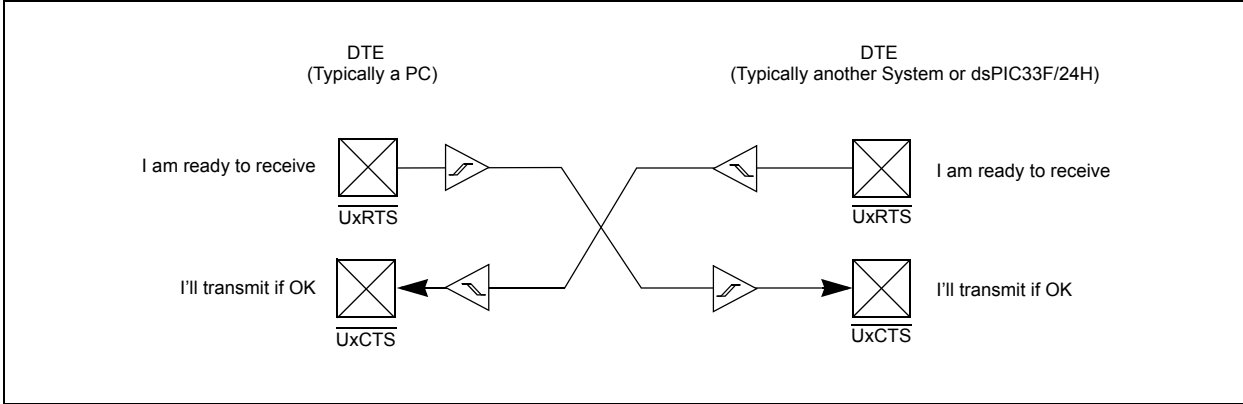

Figure 17-18: $\overline{UxRTS}/\overline{UxCTS}$ Handshake for DTE-DCE (RTSMD = 1, Simplex Mode)

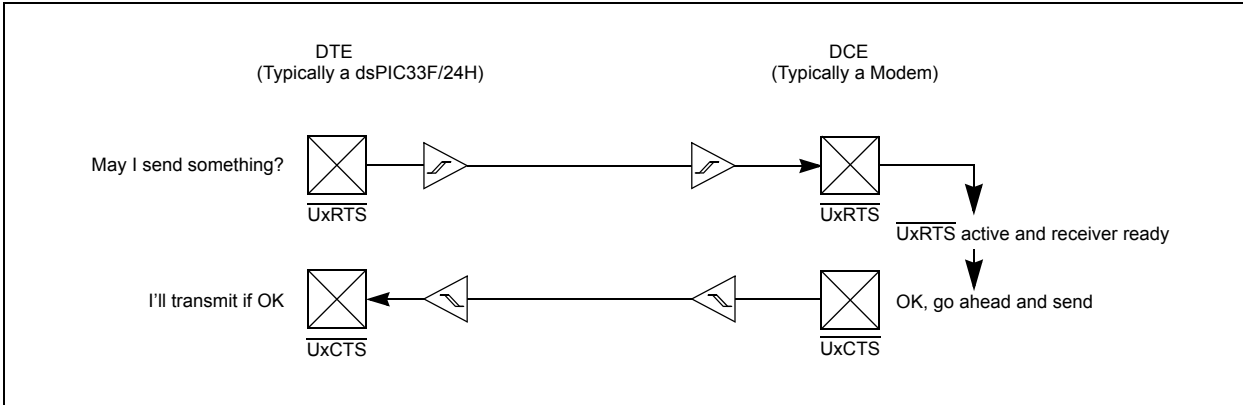
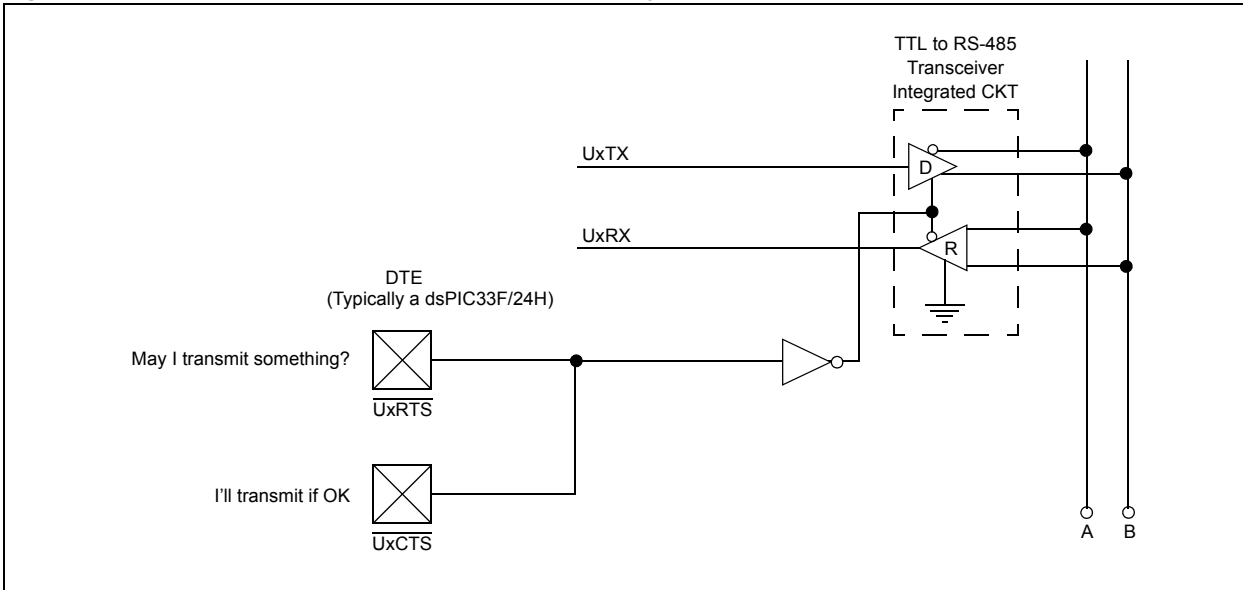

Figure 17-19: $\overline{UxRTS}/\overline{UxCTS}$ Bus Enable for IEEE-485 Systems (RTSMD = 1)



17.13 INFRARED SUPPORT

The UART module provides the following infrared UART support:

- IrDA clock output to support the external IrDA encoder and decoder devices (legacy module support)
- Full implementation of the IrDA encoder and decoder

Note: This feature is available only in Low-Speed mode (BRGH = 0), with a Baud rate above 1200 Baud.

17.13.1 External IrDA Support – IrDA Clock Output

To support external IrDA encoder and decoder devices, the BCLKx pin can be configured to generate the 16x baud clock. When UEN<1:0> = 11, the BCLKx pin will output the 16x baud clock if the UART module is enabled; it can be used to support the IrDA codec chip.

17.13.2 Built-In IrDA Encoder and Decoder

The UART has implementation of the IrDA encoder and decoder as part of the UART module. The built-in IrDA encoder and decoder functionality is enabled using the IREN bit (UxMODE<12>). When enabled (IREN = 1), the receive pin (UxRX) acts as the input from the infrared receiver. The transmit pin (UxTX) acts as the output to the infrared transmitter.

17.13.2.1 IrDA ENCODER FUNCTION

The encoder works by taking the serial data from the UART and replacing it as explained in the following section.

Transmit bit data of '1' gets encoded as '0' for the entire 16 periods of the 16x Baud clock. Transmit bit data of '0' gets encoded as '0' for the first 7 periods of the 16x Baud clock, as '1' for the next 3 periods and as '0' for the remaining 6 periods. See Figure 17-20 and Figure 17-22 for additional information.

17.13.2.2 TRANSMIT POLARITY

The transmit polarity is selected using the UTXINV bit (UxSTA<14>). When UTXINV = 0, the Idle state of the UxTX line is '0' (see Figure 17-20). When UTXINV = 1, the Idle state of the UxTX line is '1' (see Figure 17-21).

Figure 17-20: IrDA® Encode Scheme

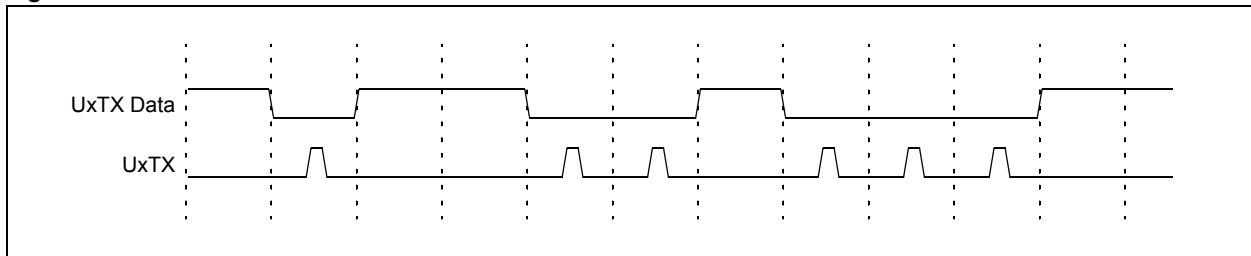

Figure 17-21: IrDA® Encode Scheme for '0' Bit Data

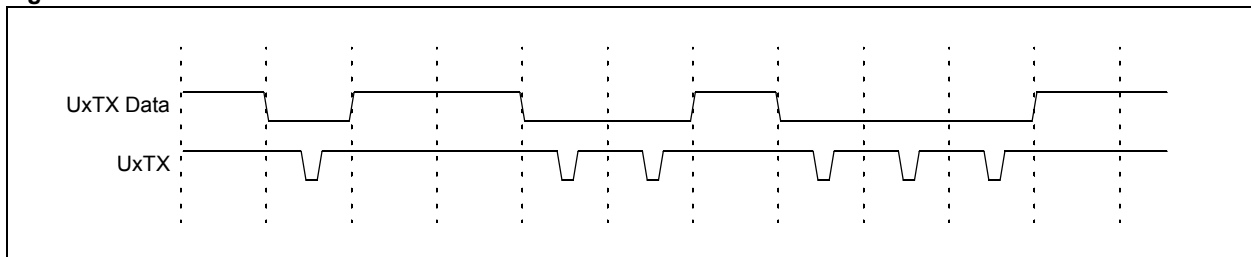
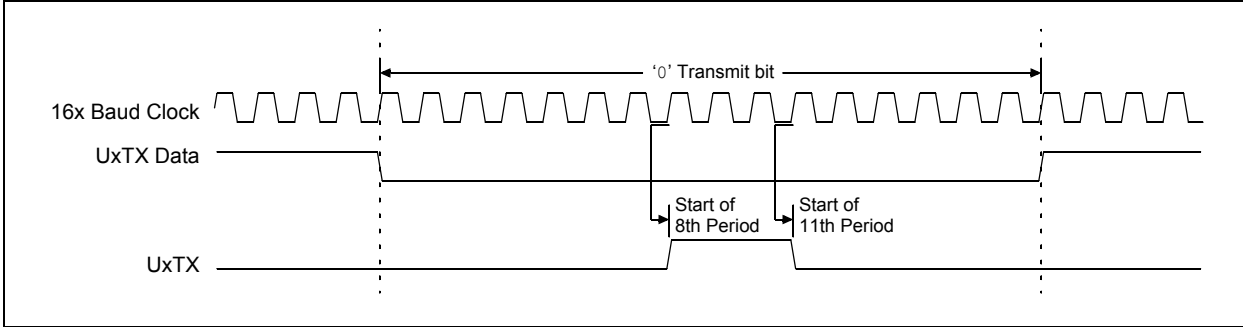

Figure 17-22: IrDA® Encode Scheme for '0' Bit Data with Respect to 16x Baud Clock



17.13.2.3 IrDA DECODER FUNCTION

The decoder works by taking the serial data from the UxRX pin and replacing it with the decoded data stream. The stream is decoded based on falling edge detection of the UxRX input.

Each falling edge of UxRX causes the decoded data to be driven low for 16 periods of the 16x Baud clock. If 16 periods expire, another falling edge is detected, the decoded data remains low for another 16 periods. If no falling edge was detected, the decoded data is driven high.

The data stream into the device is shifted from 7 to 8 periods of the 16x Baud clock from the message source. The one clock uncertainty is due to the clock edge resolution. For more information, see Figure 17-23.

Figure 17-23: IrDA® Decoding Scheme

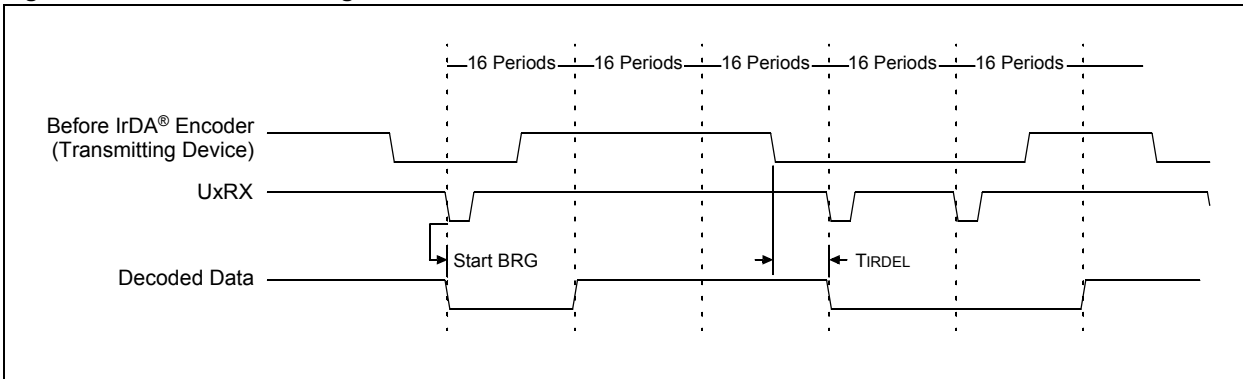

17.13.2.4 IrDA RECEIVE POLARITY

The IrDA signal input can have an inverted polarity. The same logic can decode the signal train, but in this case, the decoded data stream is shifted from 10 to 11 periods of the 16x Baud clock from the original message source. The one clock uncertainty is due to the clock edge resolution. For more information, see Figure 17-24.

Figure 17-24: Inverted Polarity Decoding Results

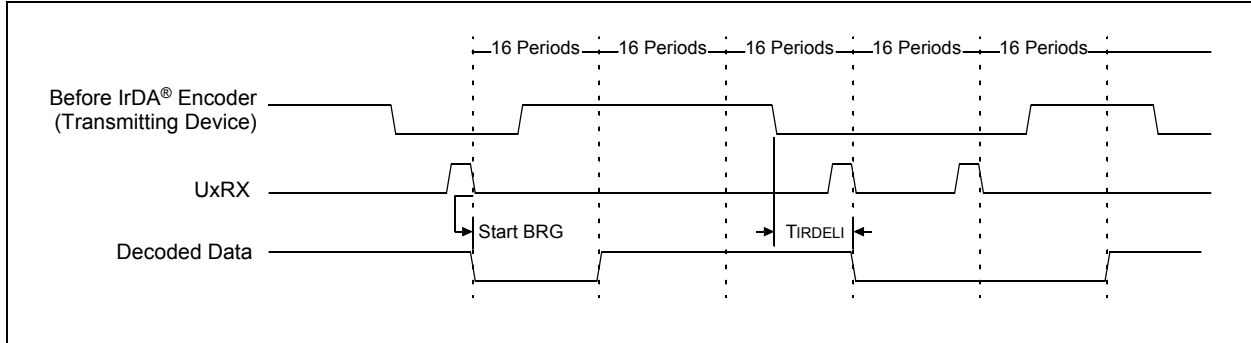

17.13.2.5 CLOCK JITTER

Due to jitter or slight frequency differences between the devices, the next falling bit edge might be missed for one of the 16x periods. In that case, a one clock wide pulse appears on the decoded data stream. Because the UART performs a majority detect around the bit center, this does not cause erroneous data. For more information, see Figure 17-25.

Figure 17-25: Clock Jitter Causing a Pulse Between Consecutive Zeros

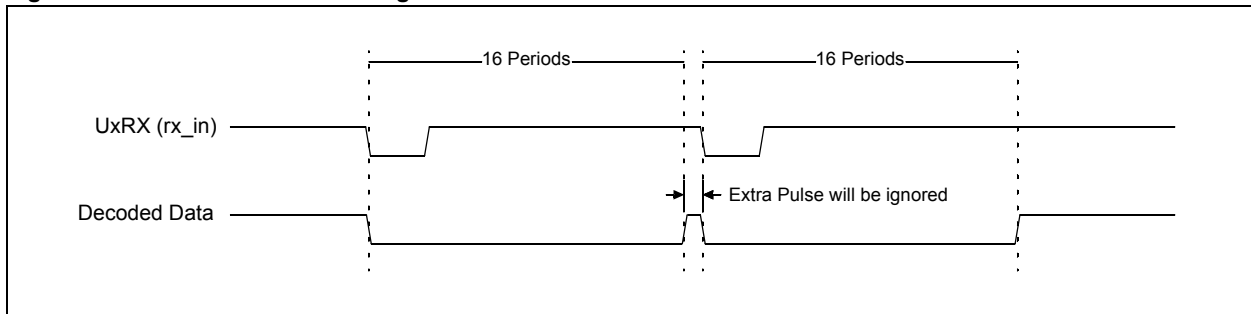

17.14 LIN SUPPORT

17.14.1 Introduction

The LIN protocol transmits data in the form of small blocks, known as frames. Each frame consists of a Break character with a delimiter, a Sync byte, a protected identifier, and the data to be transmitted. For more information, see Figure 17-26.

- Break Sequence: The break sequence indicates the beginning of a new frame. A break sequence generated by the master node consists of a Start bit followed by twelve bits of '0' and a break delimiter.
- Sync Byte: The Sync is a byte field loaded with the data value of 0x55. When the Auto-Baud feature is enabled, the UART module uses the Sync byte to compute the baud rate of the incoming data.
- Protected Identifier: The Protected Identifier contains the identifier and the identifier parity.

Figure 17-26: Frame Structure

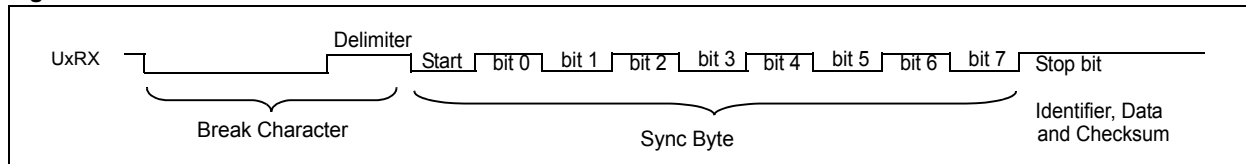

17.14.2 Data Reception Using LIN Protocol

When the LIN protocol is used, the UART module receives data in the form of frames and the incoming data is loaded into the receive buffer. For effective data reception, the BRG counter should be loaded with the Baud rate of incoming data.

In the following scenarios the bit rate of the incoming data can be detected:

- The Auto-Baud feature is enabled
- The WAKE bit is set before setting the ABAUD bit

The UART module uses the Sync byte to compute the baud rate of the incoming data. If the Wake bit is set before setting the ABAUD bit, the Auto-Baud Rate Detection occurs on the byte following the Break character. The module receives the Start bit of the Break character, the data and the invalid Stop bit (which sets FERR), but the receiver waits for a valid Stop bit before receiving the next Start bit. No further reception can occur until a Stop bit is received. The Wake bit is cleared after the Stop bit is received. After the fifth rising edge of the Sync character is detected, the Baud rate of the incoming data is loaded into the BRG counter and the ABAUD bit is automatically cleared.

If the Auto-Baud feature is enabled without setting the Wake bit, the delimiter is assumed to be the first bit of the Sync byte instead of the Start bit. This results in erroneous Baud rate calculation. This is because the receiver expects a Sync byte at the start of the reception. The LIN protocol, however, initiates the transmission with the Break character and the Sync byte follows. Thus, the delimiter, which can range from one to four bits, is assumed to be the first low-to-high transition on the RX line. Therefore, the delimiter acts as a first bit of the Sync byte instead of the Start bit. For more information, see Figure 17-27.

Note: Before data reception, the user application should load the BRG counter of the UART module with a value approximate to the bit rate of the incoming data.

Figure 17-27: Data Reception Using the LIN Protocol

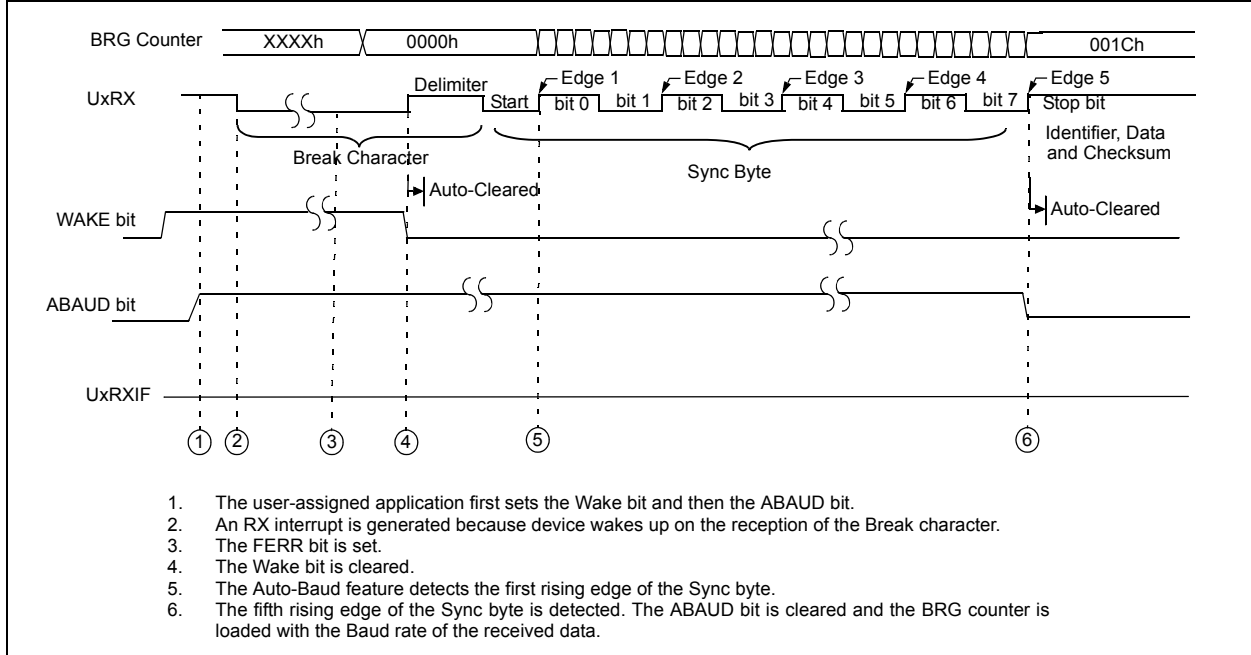

17.15 REGISTER MAP

A summary of the registers associated with the dsPIC33F/PIC24H family UARTx module is provided in Table 17-4.

Table 17-4: Registers Associated with UARTx

SFR Name	Bit 15	Bit 14	Bit 13	Bit 12	Bit 11	Bit 10	Bit 9	Bit 8	Bit 7	Bit 6	Bit 5	Bit 4	Bit 3	Bit 2	Bit 1	Bit 0	All Resets
UxMODE	UARTEN	—	USIDL	IREN	RTSMD	—	UEN<1:0>		WAKE	LPBACK	ABAUD	URXINV	BRGH	PDSEL<1:0>		STSEL	0000
UxSTA	UTXISEL1	UTXINV	UTXISEL0	—	UTXBRK	UTXEN	UTXBF	TRMT	URXISEL<1:0>		ADDEN	RIDLE	PERR	FERR	OERR	URXDA	0110
UxTXREG	—	—	—	—	—	—	—	UTX8	Transmit Register								xxxx
UxRXREG	—	—	—	—	—	—	—	URX8	Receive Register								0000
UxBRG	Baud Rate Generator Prescaler																0000
IFS0	—	—	—	U1TXIF	U1RXIF	—	—	—	—	—	—	—	—	—	—	—	0000
IFS1	U2TXIF	U2RXIF	—	—	—	—	—	—	—	—	—	—	—	—	—	—	0000
IFS4	—	—	—	—	—	—	—	—	—	—	—	—	—	U2EIF	U1EIF	—	0000
IEC0	—	—	—	U1TXIE	U1RXIE	—	—	—	—	—	—	—	—	—	—	—	0000
IEC1	U2TXIE	U2RXIE	—	—	—	—	—	—	—	—	—	—	—	—	—	—	0000
IEC4	—	—	—	—	—	—	—	—	—	—	—	—	—	U2EIE	U1EIE	—	0000
IPC2	—	U1RXIP<2:0>			—	—	—	—	—	—	—	—	—	—	—	—	4444
IPC3	—	—	—	—	—	—	—	—	—	—	—	—	—	U1TXIP<2:0>			4444
IPC7	—	U2TXIP<2:0>			—	U2RXIP<2:0>			—	—	—	—	—	—	—	—	4444
IPC16	—	—	—	—	—	U2EIP<2:0>			—	U1EIP<2:0>			—	—	—	—	4444

Legend: x = unknown value on Reset, — = unimplemented, read as '0'. Reset values are shown in hexadecimal.

Note: The registers associated with UARTx are shown for reference. See the device data sheet for the registers associated with other UART modules.

17.16 DESIGN TIPS

Question 1: *The data I transmit with the UART does not get received correctly. What could cause this?*

Answer: The most common reason for reception errors is that an incorrect value has been calculated for the UART Baud Rate Generator. Ensure the value written to the UxBRG register is correct.

Question 2: *I am getting framing errors even though the signal on the UART receive pin looks correct. What are the possible causes?*

Answer: Ensure the following control bits have been set up correctly:

- UxBRG: UART Baud Rate register
- PDSEL<1:0>: Parity and Data Size Selection bits
- STSEL: Stop bit Selection

17.17 RELATED APPLICATION NOTES

This section lists application notes that are related to this section of the manual. These application notes may not be written specifically for the dsPIC33F/PIC24H device family, but the concepts are pertinent and could be used with modification and possible limitations. The current application notes related to the UART module include the following:

Title	Application Note #
Related application notes are not available.	N/A

Note: Visit Microchip web site (www.microchip.com) for additional application notes and code examples for the dsPIC33F/PIC24H family of devices.

17.18 REVISION HISTORY

Revision A (February 2007)

This is the initial released revision of this document.

Revision B (February 2007)

Minor edits throughout document.

Revision C (June 2008)

This revision includes the following corrections and updates:

- Minor typographical and formatting corrections throughout the document
- Updated LIN reference in “”
- Added functional description of each register in **17.2 “Control Registers”**
- Changed bit value description for bit 14 in the UxSTA: UARTx Status and Control Register (see Register 17-2)
- Modified the BCLKx output status information in **17.3.1 “BCLKx Output”**
- Replaced last paragraph and added Figure 17-4 in **17.5 “UART Transmitter”** to describe the importance of a software delay between enabling the UART module and loading the data into the UARTx Transmit register.
- Added **17.6 “Data Bit Detection”**
- Removed the second sentence from the last paragraph of **17.7.2 “Receiver Error Handling”**
- Removed 17.8 “Receiving Break Characters”. This is covered in **17.14 “LIN Support”**
- Removed the fourth sentence from the first paragraph and the third sentence from the second paragraph of **17.9.2 “Auto-Baud Support”**
- Removed 17.9.2.1 “Break Detect Sequence”. This is covered in **17.14 “LIN Support”**
- Updated **17.11 “UART Operation During CPU Sleep and Idle Modes”**
- Added a Note to **17.13 “Infrared Support”**
- Removed references to the IrDA **17.13.2.2 “Transmit Polarity”**
- Added **17.14 “LIN Support”**

Revision D (May 2010)

This revision includes the following corrections and updates:

- Minor typographical and formatting corrections throughout the document
- Changed bit value description for bit 14 in the UxSTA: UARTx Status and Control Register (see Register 17-2)
- Merged dsPIC33F and PIC24H family reference manual sections.
- Updated **17.10 “UART Operation with DMA”**.
- Updated **Example 17-4: “UART Reception and Transmission with DMA”**.
- Added a note **17.7.4 “Setup for UART Reception”**
- Updated the note under **17.11.2 “UART Operation in Idle Mode”**
- Changed the figure **Figure 17-11: “UART Reception”**

NOTES:

Note the following details of the code protection feature on Microchip devices:

- Microchip products meet the specification contained in their particular Microchip Data Sheet.
- Microchip believes that its family of products is one of the most secure families of its kind on the market today, when used in the intended manner and under normal conditions.
- There are dishonest and possibly illegal methods used to breach the code protection feature. All of these methods, to our knowledge, require using the Microchip products in a manner outside the operating specifications contained in Microchip's Data Sheets. Most likely, the person doing so is engaged in theft of intellectual property.
- Microchip is willing to work with the customer who is concerned about the integrity of their code.
- Neither Microchip nor any other semiconductor manufacturer can guarantee the security of their code. Code protection does not mean that we are guaranteeing the product as “unbreakable.”

Code protection is constantly evolving. We at Microchip are committed to continuously improving the code protection features of our products. Attempts to break Microchip's code protection feature may be a violation of the Digital Millennium Copyright Act. If such acts allow unauthorized access to your software or other copyrighted work, you may have a right to sue for relief under that Act.

Information contained in this publication regarding device applications and the like is provided only for your convenience and may be superseded by updates. It is your responsibility to ensure that your application meets with your specifications. MICROCHIP MAKES NO REPRESENTATIONS OR WARRANTIES OF ANY KIND WHETHER EXPRESS OR IMPLIED, WRITTEN OR ORAL, STATUTORY OR OTHERWISE, RELATED TO THE INFORMATION, INCLUDING BUT NOT LIMITED TO ITS CONDITION, QUALITY, PERFORMANCE, MERCHANTABILITY OR FITNESS FOR PURPOSE. Microchip disclaims all liability arising from this information and its use. Use of Microchip devices in life support and/or safety applications is entirely at the buyer's risk, and the buyer agrees to defend, indemnify and hold harmless Microchip from any and all damages, claims, suits, or expenses resulting from such use. No licenses are conveyed, implicitly or otherwise, under any Microchip intellectual property rights.

Trademarks

The Microchip name and logo, the Microchip logo, dsPIC, KEELOQ, KEELOQ logo, MPLAB, PIC, PICmicro, PICSTART, PIC³² logo, rPIC and UNI/O are registered trademarks of Microchip Technology Incorporated in the U.S.A. and other countries.

FilterLab, Hampshire, HI-TECH C, Linear Active Thermistor, MXDEV, MXLAB, SEEVAL and The Embedded Control Solutions Company are registered trademarks of Microchip Technology Incorporated in the U.S.A.

Analog-for-the-Digital Age, Application Maestro, CodeGuard, dsPICDEM, dsPICDEM.net, dsPICworks, dsSPEAK, ECAN, ECONOMONITOR, FanSense, HI-TIDE, In-Circuit Serial Programming, ICSP, Mindi, MiWi, MPASM, MPLAB Certified logo, MPLIB, MPLINK, mTouch, Octopus, Omniscient Code Generation, PICC, PICC-18, PICDEM, PICDEM.net, PICkit, PICTail, REAL ICE, rLAB, Select Mode, Total Endurance, TSHARC, UniWinDriver, WiperLock and ZENA are trademarks of Microchip Technology Incorporated in the U.S.A. and other countries.

SQTP is a service mark of Microchip Technology Incorporated in the U.S.A.

All other trademarks mentioned herein are property of their respective companies.

© 2010, Microchip Technology Incorporated, Printed in the U.S.A., All Rights Reserved.

 Printed on recycled paper.

ISBN: 978-1-60932-162-8

Microchip received ISO/TS-16949:2002 certification for its worldwide headquarters, design and wafer fabrication facilities in Chandler and Tempe, Arizona; Gresham, Oregon and design centers in California and India. The Company's quality system processes and procedures are for its PIC[®] MCUs and dsPIC[®] DSCs, KEELOQ[®] code hopping devices, Serial EEPROMs, microperipherals, nonvolatile memory and analog products. In addition, Microchip's quality system for the design and manufacture of development systems is ISO 9001:2000 certified.

**QUALITY MANAGEMENT SYSTEM
CERTIFIED BY DNV
== ISO/TS 16949:2002 ==**



WORLDWIDE SALES AND SERVICE

AMERICAS

Corporate Office
2355 West Chandler Blvd.
Chandler, AZ 85224-6199
Tel: 480-792-7200
Fax: 480-792-7277
Technical Support:
<http://support.microchip.com>
Web Address:
www.microchip.com

Atlanta
Duluth, GA
Tel: 678-957-9614
Fax: 678-957-1455

Boston
Westborough, MA
Tel: 774-760-0087
Fax: 774-760-0088

Chicago
Itasca, IL
Tel: 630-285-0071
Fax: 630-285-0075

Cleveland
Independence, OH
Tel: 216-447-0464
Fax: 216-447-0643

Dallas
Addison, TX
Tel: 972-818-7423
Fax: 972-818-2924

Detroit
Farmington Hills, MI
Tel: 248-538-2250
Fax: 248-538-2260

Kokomo
Kokomo, IN
Tel: 765-864-8360
Fax: 765-864-8387

Los Angeles
Mission Viejo, CA
Tel: 949-462-9523
Fax: 949-462-9608

Santa Clara
Santa Clara, CA
Tel: 408-961-6444
Fax: 408-961-6445

Toronto
Mississauga, Ontario,
Canada
Tel: 905-673-0699
Fax: 905-673-6509

ASIA/PACIFIC

Asia Pacific Office
Suites 3707-14, 37th Floor
Tower 6, The Gateway
Harbour City, Kowloon
Hong Kong
Tel: 852-2401-1200
Fax: 852-2401-3431

Australia - Sydney
Tel: 61-2-9868-6733
Fax: 61-2-9868-6755

China - Beijing
Tel: 86-10-8528-2100
Fax: 86-10-8528-2104

China - Chengdu
Tel: 86-28-8665-5511
Fax: 86-28-8665-7889

China - Chongqing
Tel: 86-23-8980-9588
Fax: 86-23-8980-9500

China - Hong Kong SAR
Tel: 852-2401-1200
Fax: 852-2401-3431

China - Nanjing
Tel: 86-25-8473-2460
Fax: 86-25-8473-2470

China - Qingdao
Tel: 86-532-8502-7355
Fax: 86-532-8502-7205

China - Shanghai
Tel: 86-21-5407-5533
Fax: 86-21-5407-5066

China - Shenyang
Tel: 86-24-2334-2829
Fax: 86-24-2334-2393

China - Shenzhen
Tel: 86-755-8203-2660
Fax: 86-755-8203-1760

China - Wuhan
Tel: 86-27-5980-5300
Fax: 86-27-5980-5118

China - Xian
Tel: 86-29-8833-7252
Fax: 86-29-8833-7256

China - Xiamen
Tel: 86-592-2388138
Fax: 86-592-2388130

China - Zhuhai
Tel: 86-756-3210040
Fax: 86-756-3210049

ASIA/PACIFIC

India - Bangalore
Tel: 91-80-3090-4444
Fax: 91-80-3090-4123

India - New Delhi
Tel: 91-11-4160-8631
Fax: 91-11-4160-8632

India - Pune
Tel: 91-20-2566-1512
Fax: 91-20-2566-1513

Japan - Yokohama
Tel: 81-45-471- 6166
Fax: 81-45-471-6122

Korea - Daegu
Tel: 82-53-744-4301
Fax: 82-53-744-4302

Korea - Seoul
Tel: 82-2-554-7200
Fax: 82-2-558-5932 or
82-2-558-5934

Malaysia - Kuala Lumpur
Tel: 60-3-6201-9857
Fax: 60-3-6201-9859

Malaysia - Penang
Tel: 60-4-227-8870
Fax: 60-4-227-4068

Philippines - Manila
Tel: 63-2-634-9065
Fax: 63-2-634-9069

Singapore
Tel: 65-6334-8870
Fax: 65-6334-8850

Taiwan - Hsin Chu
Tel: 886-3-6578-300
Fax: 886-3-6578-370

Taiwan - Kaohsiung
Tel: 886-7-536-4818
Fax: 886-7-536-4803

Taiwan - Taipei
Tel: 886-2-2500-6610
Fax: 886-2-2508-0102

Thailand - Bangkok
Tel: 66-2-694-1351
Fax: 66-2-694-1350

EUROPE

Austria - Wels
Tel: 43-7242-2244-39
Fax: 43-7242-2244-393

Denmark - Copenhagen
Tel: 45-4450-2828
Fax: 45-4485-2829

France - Paris
Tel: 33-1-69-53-63-20
Fax: 33-1-69-30-90-79

Germany - Munich
Tel: 49-89-627-144-0
Fax: 49-89-627-144-44

Italy - Milan
Tel: 39-0331-742611
Fax: 39-0331-466781

Netherlands - Drunen
Tel: 31-416-690399
Fax: 31-416-690340

Spain - Madrid
Tel: 34-91-708-08-90
Fax: 34-91-708-08-91

UK - Wokingham
Tel: 44-118-921-5869
Fax: 44-118-921-5820