



Section 45. High-Speed Analog Comparator

HIGHLIGHTS

This section of the manual contains the following major topics:

45.1	Introduction	45-2
45.2	Features Overview	45-2
45.3	Module Description	45-3
45.4	Control Registers	45-4
45.5	Configuring the High-Speed Analog Comparator.....	45-7
45.6	Application Information	45-8
45.7	High-Speed Analog Comparator Limitations.....	45-9
45.8	Register Maps.....	45-10
45.9	Related Application Notes.....	45-11
45.10	Revision History	45-12

45.1 INTRODUCTION

The High-Speed Analog Comparator module in the dsPIC33F Switch Mode Power Supply (SMPS) and Digital Power Conversion device family provides a way to monitor voltage and currents in a power conversion application.

The High-Speed Analog Comparator module contains up to four high-speed analog comparators with dedicated 10-bit Digital-to-Analog Converters (DACs) that provide a programmable reference voltage to one input of the comparator.

45.2 FEATURES OVERVIEW

The following is a list of key features of the High-Speed Analog Comparator module:

- Up to four analog comparators
- Dedicated 10-bit DAC for each analog comparator
- Programmable output polarity
- Interrupt generation capability
- Up to 16 selectable input sources
- DAC output
- Multiple voltage references for the DAC:
 - $AV_{DD}/2$
 - Internal Reference $1.2V \pm 1\%$
 - External Reference $< (AV_{DD} - 1.6V)$
- Analog-to-Digital Converter (ADC) sample and convert trigger capability
- Ability to disable the High-Speed Analog Comparator module to reduce power consumption
- Functional support for High-Speed Power Supply PWM module, which includes:
 - PWM Duty Cycle Control
 - PWM Period Control
 - PWM Fault Detect

Section 45. High-Speed Analog Comparator

45.3 MODULE DESCRIPTION

Figure 45-1 shows a functional block diagram of one analog comparator from the High-Speed Analog Comparator module.

The analog comparator provides high speed operation with a typical delay of 20 ns. The comparator has a typical offset voltage of ± 5 mV. The negative input of the comparator is always connected to the DAC circuit. The positive input of the comparator is connected to an analog multiplexer that selects the desired source pin.

The analog comparator input pins are typically shared with pins used by the ADC module. Both the comparator and the ADC can use the same pins at the same time. This capability enables a user to measure an input voltage with the ADC and detect voltage transients with the comparator.

Figure 45-1: SMPS Comparator Module Block Diagram

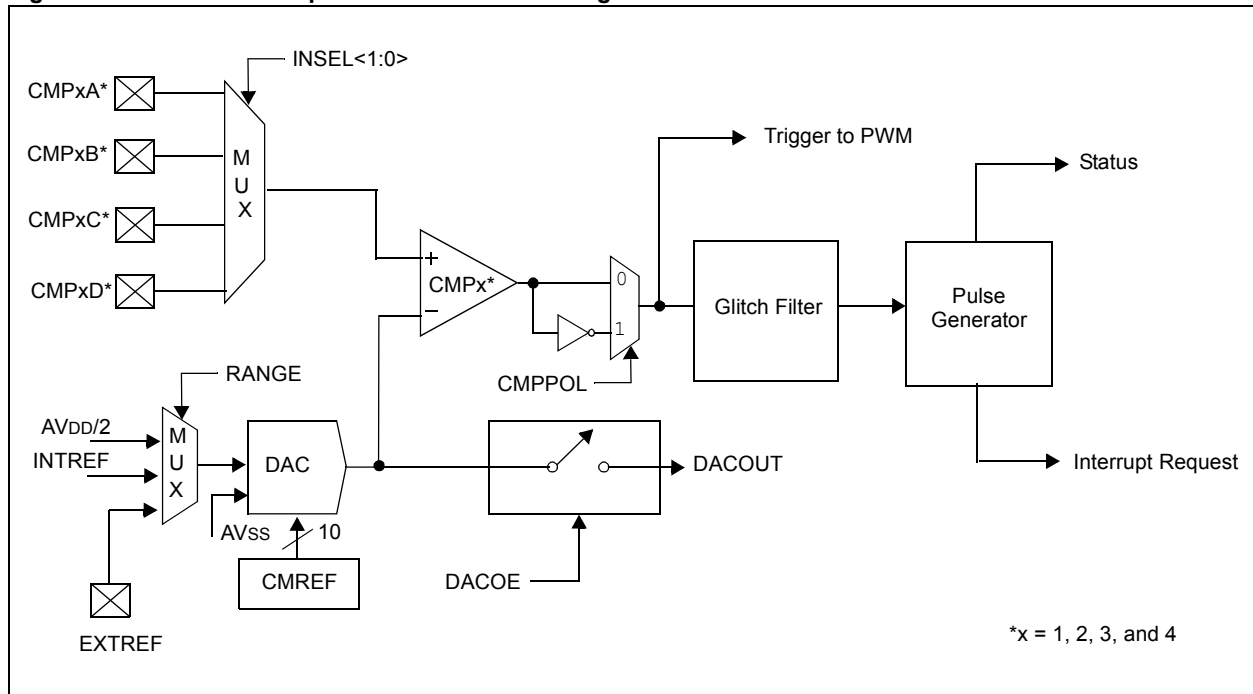

45.4 CONTROL REGISTERS

The following registers are used to configure the High-Speed Analog Comparator module:

- **Comparator Control Register x (CMPCONx)**

This register is used to configure the comparator voltage reference source, input pin and output polarity. Depending on the device variant, there are up to four individual registers (CMPCON1-CMPCON4), which correspond to the respective comparator.

- **Comparator DAC Control Register x (CMPDACx)**

The contents of this register determine the threshold voltage for the comparator. Depending on the device variant, there are up to four individual registers (CMPDAC1-CMPDAC4), which correspond to the respective comparator.

Section 45. High-Speed Analog Comparator

Register 45-1: Comparator Control Register x (CMPCONx)

R/W-0	U-0	R/W-0	U-0	U-0	U-0	U-0	R/W-0
CMPON	—	CMPSIDL	—	—	—	—	DACOE
bit 15							bit 8
R/W-0	R/W-0	R/W-0	U-0	R-0	U-0	R/W-0	R/W-0
INSEL<1:0>		EXTREF	—	CMPSTAT	—	CMPPOL	RANGE
bit 7							bit 0

Legend:

R = Readable bit	W = Writable bit	U = Unimplemented bit, read as '0'
-n = Value at POR	'1' = Bit is set	'0' = Bit is cleared x = Bit is unknown

- bit 15 **CMPON:** Comparator A/D Operating Mode bit
 1 = Comparator module is enabled
 0 = Comparator module is disabled (reduces power consumption)
- bit 14 **Unimplemented:** Read as '0'
- bit 13 **CMPSIDL:** Comparator Stop in Idle Mode bit
 1 = Discontinue module operation when device enters Idle mode
 0 = Continue module operation in Idle mode
 If a device has multiple comparators, any CMPSIDL bit set to '1' will disable all comparators while in Idle mode.
- bit 12-9 **Reserved:** Read as '0'
- bit 8 **DACOE:** DAC Output Enable
 1 = DAC analog voltage is output to DACOUT pin⁽¹⁾
 0 = DAC analog voltage is not connected to DACOUT pin
- bit 7-6 **INSEL<1:0>:** Comparator Input Source Select bit
 00 = Select CMPxA input pin
 01 = Select CMPxB input pin
 10 = Select CMPxC input pin
 11 = Select CMPxD input pin
- bit 5 **EXTREF:** External Reference Enable bit
 1 = External source provides reference to DAC (maximum DAC voltage determined by external voltage source)
 0 = Internal reference sources provide reference to DAC (maximum DAC voltage determined by RANGE bit setting)
- bit 4 **Reserved:** Read as '0'
- bit 3 **CMPSTAT:** Current state of comparator output including CMPPOL selection
- bit 2 **Reserved:** Read as '0'
- bit 1 **CMPPOL:** Comparator Output Polarity Control bit
 1 = Output is inverted
 0 = Output is not inverted
- bit 0 **RANGE:** DAC Output Voltage Range bit
 1 = High range: Max DAC value = AVDD/2 (1.65V @ 3.3V AVDD)
 0 = Low range: Max DAC value = INTREF (1.2V ±1%)

Note 1: DACOUT can only be associated with a single comparator at any given time.

45.5 CONFIGURING THE HIGH-SPEED ANALOG COMPARATOR

The High-Speed Analog Comparator module is configured using the CMPCONx register. The INSEL<1:0> bits are used to select the comparator input pin. The signal to be monitored must be connected to this pin.

The EXTREF bit in the CMPCONx register selects between an external reference source or the internal reference source. If the EXTREF bit is set (CMPCONx<5> = 1), the voltage applied to the EXTREF pin provides the comparator reference voltage.

If the EXTREF bit is cleared (CMPCONx<5> = 0), the RANGE bit (CMPCONx<0>) in the CMPCONx register determines the comparator reference voltage. If Low Range is selected (CMPCONx<0> = 0), the internal band gap reference (INTREF) provides the comparator reference. If High Range is selected (CMPCONx<0> = 1), AVDD/2 provides the comparator reference.

45.5.1 10-bit DAC

Each analog comparator in the High-Speed Analog Comparator module has a dedicated 10-bit DAC that is used to program the comparator threshold voltage.

Each DAC has an output enable bit (DACOE) in the Comparator Control (CMPCONx<8>) register that enables the DAC reference voltage to be an output on the device (DACOUT). DACOUT can only be associated with a single comparator at any given time. When more than one DACOE bit is set, the DACOUT pin will reflect the DAC output of the comparator with the highest priority. The comparator priority is based on the comparator number, with Comparator 1 having the highest priority.

The full range of the DAC (AVDD/2) will typically be used when the chosen input source pin is shared with an ADC input.

The reduced range option (INTREF) is typically used when monitoring currents via a current sense shunt resistor. Usually, the measured voltages in such applications are small (< 1.25V); therefore, the option of using a reduced reference range for the comparator extends the available DAC resolution in these applications.

The use of an external reference enables the user to connect to a reference that better suits their application.

45.5.2 Interaction with Digital I/O Pin Buffers

If the High-Speed Analog Comparator module is enabled and a pin has been selected as the source for the comparator, then the digital input buffer associated with that pin will be disabled. This is done to prevent excessive currents in the digital buffer due to analog input voltages.

45.5.3 Glitch Filter

The High-Speed Analog Comparator module provides a glitch filter for the comparator output to mask transient signals less than two instruction cycles in a duration. In Sleep or Idle mode, the glitch filter is bypassed to enable an asynchronous signal from the comparator to the interrupt controller. This asynchronous signal can be used to wake up the processor from Sleep or Idle mode.

45.5.4 Operation in Sleep and Idle Modes

The comparator can be disabled while in Idle mode if the CMPSIDL bit in the CMPCONx register is set (CMPCONx<13> = 1). Setting the CMPSIDL bit for any one of the comparators causes the entire High-Speed Analog Comparator module to be disabled while in Idle mode.

If the High-Speed Analog Comparator module is disabled (CMPCONx<15> = 0), all of the analog comparators and the DACs are disabled to reduce power consumption.

45.6 APPLICATION INFORMATION

The High-Speed Analog Comparator module provides high-speed analog comparators that can be used in many power conversion applications. The outputs of the High-Speed Analog Comparator module can be used to perform the following functions:

- Generate an interrupt
- Trigger an ADC sample and convert process
- Truncate the PWM signal (current limit)
- Truncate the PWM period (current reset)
- Disable the PWM outputs (fault-latch)

The output of the High-Speed Analog Comparator module can be used in multiple modes at the same time. For example, comparator output can be used to generate an interrupt, have the ADC take a sample and convert it, and truncate the PWM output, all in response to a voltage being detected beyond its expected value.

The comparator can also be used to wake up the system from Sleep or Idle mode when the analog input voltage exceeds the programmed threshold voltage.

The potential applications of the High-Speed Analog Comparator module are numerous and varied. The following section describes some typical applications in power conversion circuits.

45.6.1 Power Factor Correction Boost Converter: PWM Reset Using High-Speed Analog Comparator

Analog comparators are widely used in a Power Factor Correction Boost Converter as shown in Figure 45-2. The High-Speed Analog Comparator module can be utilized for this application instead of adding expensive circuitry. The High-Speed Analog Comparator is used in conjunction with the High-Speed Power Supply PWM module to generate the Current Reset mode PWM signal. For more information on this PWM mode of operation, refer to **Section 43: “High-Speed Power Supply PWM”**.

The High-Speed Analog Comparator is configured to reset the PWM module when the measured current through the inductor falls below the minimum acceptable current level. This minimum current level is determined by the application.

Initially, the power semiconductor switch is turned ON. After a constant ON time, the switch is turned OFF and the PWM module waits for the current to decay below the comparator threshold. When the current falls below the threshold, the comparator resets the PWM module, turning the power semiconductor switch back ON and thereby energizing the inductor again.

Figure 45-2: Application of Current Reset PWM Mode

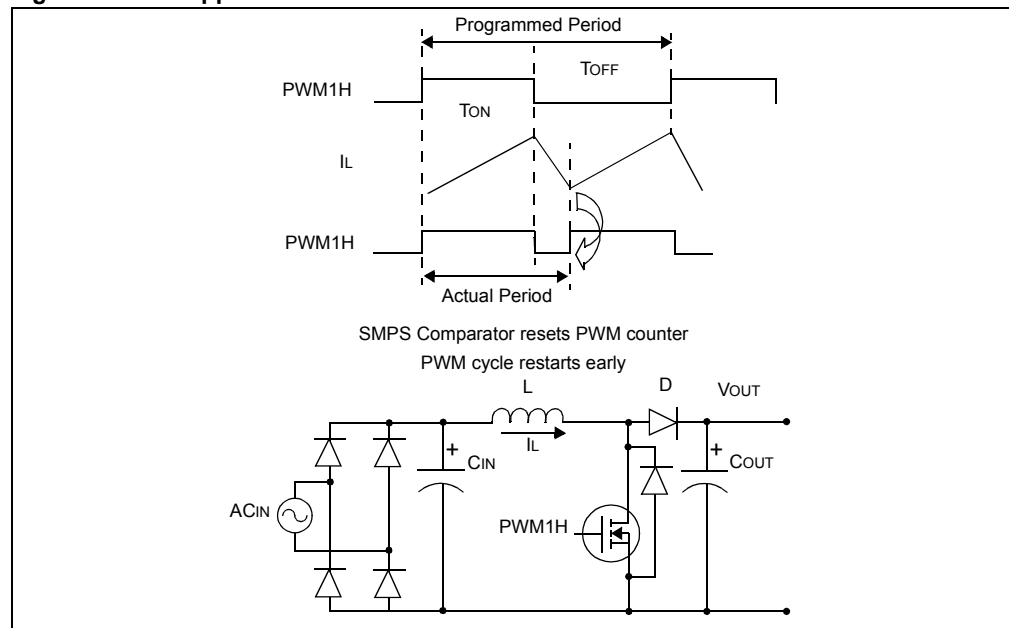

45.7 HIGH-SPEED ANALOG COMPARATOR LIMITATIONS

45.7.1 Comparator Input Range

The analog comparator has a limitation for the input Common Mode Range (CMR) of $(AV_{DD} - 1.5V)$ typical. This means that both inputs to the comparator (the chosen CMPx input pin and the selected reference source) should be within this range. As long as one of the inputs is within the CMR, the comparator output will be correct. However, any input exceeding the CMR limitation will cause the comparator input to be saturated.

If both inputs exceed the CMR, the comparator output will be indeterminate.

45.7.2 DAC Output Range

The maximum reference voltage input to the DAC should not exceed $(AV_{DD} - 1.6V)$. If the external reference voltage input exceeds this value, the DAC output will become indeterminate.

45.7.3 EXTREF Range

If EXTREF is selected as the comparator reference source, the voltage at the EXTREF pin should not exceed $(AV_{DD} - 1.5V)$. If the voltage at EXTREF exceeds this value, the comparator output can become unpredictable.

45.8 REGISTER MAPS

A summary of the registers associated with the High-Speed Analog Comparator module is provided in Table 45-1.

Table 45-1: Analog Comparator Control Register Map

File Name	ADR	Bit 15	Bit 14	Bit 13	Bit 12	Bit 11	Bit 10	Bit 9	Bit 8	Bit 7	Bit 6	Bit 5	Bit 4	Bit 3	Bit 2	Bit 1	Bit 0	All Resets
CMPCON1	0540	CMPON	—	CMPSIDL	—	—	—	—	DACOE	INSEL<1:0>	—	EXTREF	—	CMPSTAT	—	CMPPOL	RANGE	0.000
CMPDAC1	0542	—	—	—	—	—	—	—	—	—	—	CMREF<9:0>	—	—	—	—	—	0.000
CMPCON2	0544	CMPON	—	CMPSIDL	—	—	—	—	DACOE	INSEL<1:0>	—	EXTREF	—	CMPSTAT	—	CMPPOL	RANGE	0.000
CMPDAC2	0546	—	—	—	—	—	—	—	—	—	—	CMREF<9:0>	—	—	—	—	—	0.000
CMPCON3	0548	CMPON	—	CMPSIDL	—	—	—	—	DACOE	INSEL<1:0>	—	EXTREF	—	CMPSTAT	—	CMPPOL	RANGE	0.000
CMPDAC3	054A	—	—	—	—	—	—	—	—	—	—	CMREF<9:0>	—	—	—	—	—	0.000
CMPCON4	054C	CMPON	—	CMPSIDL	—	—	—	—	DACOE	INSEL<1:0>	—	EXTREF	—	CMPSTAT	—	CMPPOL	RANGE	0.000
CMPDAC4	054E	—	—	—	—	—	—	—	—	—	—	CMREF<9:0>	—	—	—	—	—	0.000

45.9 RELATED APPLICATION NOTES

This section lists application notes that are related to this section of the manual. These application notes may not be written specifically for the dsPIC33F product family, but the concepts are pertinent and could be used with modification and possible limitations. The current application notes related to the High-Speed Analog Comparator module are:

Title	Application Note #
No related applications notes at this time.	

Note: Please visit the Microchip web site (www.microchip.com) for additional Application Notes and code examples for the dsPIC33F family of devices.

45.10 REVISION HISTORY

Revision A (September 2007)

This is the initial release of this document.