

---

---

## Section 2. CPU

---

---

### HIGHLIGHTS

This section of the manual contains the following topics:

2.1	Introduction .....	2-2
2.2	Programmer's Model.....	2-5
2.3	Software Stack Pointer.....	2-9
2.4	CPU Register Descriptions .....	2-12
2.5	Arithmetic Logic Unit.....	2-17
2.6	DSP Engine .....	2-18
2.7	Divide Support .....	2-27
2.8	Instruction Flow Types .....	2-28
2.9	Loop Constructs.....	2-31
2.10	Address Register Dependencies .....	2-37
2.11	Register Maps.....	2-40
2.12	Related Application Notes.....	2-42
2.13	Revision History .....	2-43

**Note:** This family reference manual section is meant to serve as a complement to device data sheets. Depending on the device variant, this manual section may not apply to all dsPIC33F/PIC24H devices.

Please consult the note at the beginning of the “**CPU**” chapter in the current device data sheet to check whether this document supports the device you are using.

Device data sheets and family reference manual sections are available for download from the Microchip Worldwide Web site at: <http://www.microchip.com>

## 2.1 INTRODUCTION

The dsPIC33F/PIC24H CPU has a 16-bit (data) modified Harvard architecture with an enhanced instruction set, including significant support for digital signal processing. The CPU has a 24-bit instruction word, with a variable length opcode field. The Program Counter (PC) is 24 bits wide and addresses up to 4M x 24 bits of user program memory space.

A single-cycle instruction prefetch mechanism helps maintain throughput and provides predictable execution. All instructions execute in a single cycle, except the instructions that change the program flow, double-word move (`MOV.D`) instruction, table instructions and also instructions accessing Program Space Visibility (PSV) take more than one cycle. Overhead-free program loop constructs are supported using the `DO` and `REPEAT` instructions, both of which are interruptible at any point.

### 2.1.1 Registers

The dsPIC33F/PIC24H devices have sixteen 16-bit working registers in the programmer's model. Each working register can operate as data, address, or address offset register. The sixteenth working register (W15) operates as a Software Stack Pointer (SSP) for interrupts and calls.

### 2.1.2 Instruction Set

The dsPIC33F/PIC24H instruction set has two classes of instructions:

- MCU class instructions
- DSP class instructions

These two instruction classes are seamlessly integrated into the architecture and execute from a single execution unit. The instruction set includes many Addressing modes and is designed for optimum C compiler efficiency.

### 2.1.3 Data Space Addressing

The data space can be addressed as 32K words or 64 Kbytes and is split into two blocks, referred to as X and Y data memory. Each memory block has its own independent Address Generation Unit (AGU). The MCU class of instructions operate solely through the X memory AGU, which accesses the entire memory map as one linear data space. A few DSP instructions operate through the X and Y AGU to support dual operand read, which splits the data address space into two parts. The X and Y data space boundary is device specific.

The upper 32 Kbytes of the data space memory map can optionally be mapped into program space at any 16K program word boundary defined by the 8-bit Program Space Visibility Page (PSVPAG) register. The Program-to-Data-Space Mapping feature allows any instruction access program space as if it were data space. Furthermore, RAM can be connected to the program memory bus on devices with an external bus, and can be used to extend the internal data RAM.

Overhead-free circular buffers (modulo addressing) are supported in both X and Y address spaces. The modulo addressing removes the software boundary-checking overhead for DSP algorithms. The X AGU circular addressing can be used with any MCU class of instructions. The X AGU also supports bit-reverse addressing to greatly simplify input or output data reordering for radix-2 FFT algorithms.

### 2.1.4 Addressing Modes

The CPU supports the following addressing modes:

- Inherent (no operand)
- Relative
- Literal
- Memory Direct
- Register Direct
- Register Indirect

Each instruction is associated with a predefined addressing mode group, depending upon its functional requirements. As many as six addressing modes are supported for each instruction.

For most instructions, the dsPIC33F/PIC24H CPU can execute the following functions in a single instruction cycle:

- Data (or program data) memory read
- Working register (data) read
- Data memory write
- Program (instruction) memory read

Therefore, three operand instructions can be supported allowing  $A + B = C$  operations to be executed in a single cycle.

### 2.1.5 DSP Engine and Instructions

Following are the DSP Engine features:

- A high-speed, 17-bit by 17-bit multiplier (for Signed 16-bit multiplication)
- A 40-bit Arithmetic Logic Unit (ALU)
- Two 40-bit saturating accumulators
- A 40-bit bidirectional barrel shifter that is capable of shifting a 40-bit value up to 16 bits right or left, in a single cycle

The DSP instructions operate seamlessly with all other instructions and are designed for optimal real-time performance. The `MAC` instruction and other associated instructions can concurrently fetch two data operands from memory while multiplying two Working (W) registers. This requires that the data space be split for these instructions and linear for all others. This is achieved in a transparent and flexible manner by dedicating certain working registers to each address space.

## 2.1.6 Exception Processing

The dsPIC33F/PIC24H CPU has a vectored exception scheme with up to eight sources of non-maskable traps and 118 interrupt sources. Each interrupt source can be assigned to one of the seven priority levels. Figure 2-1 shows the CPU block diagram.

Figure 2-1: dsPIC33F/PIC24H CPU Block Diagram

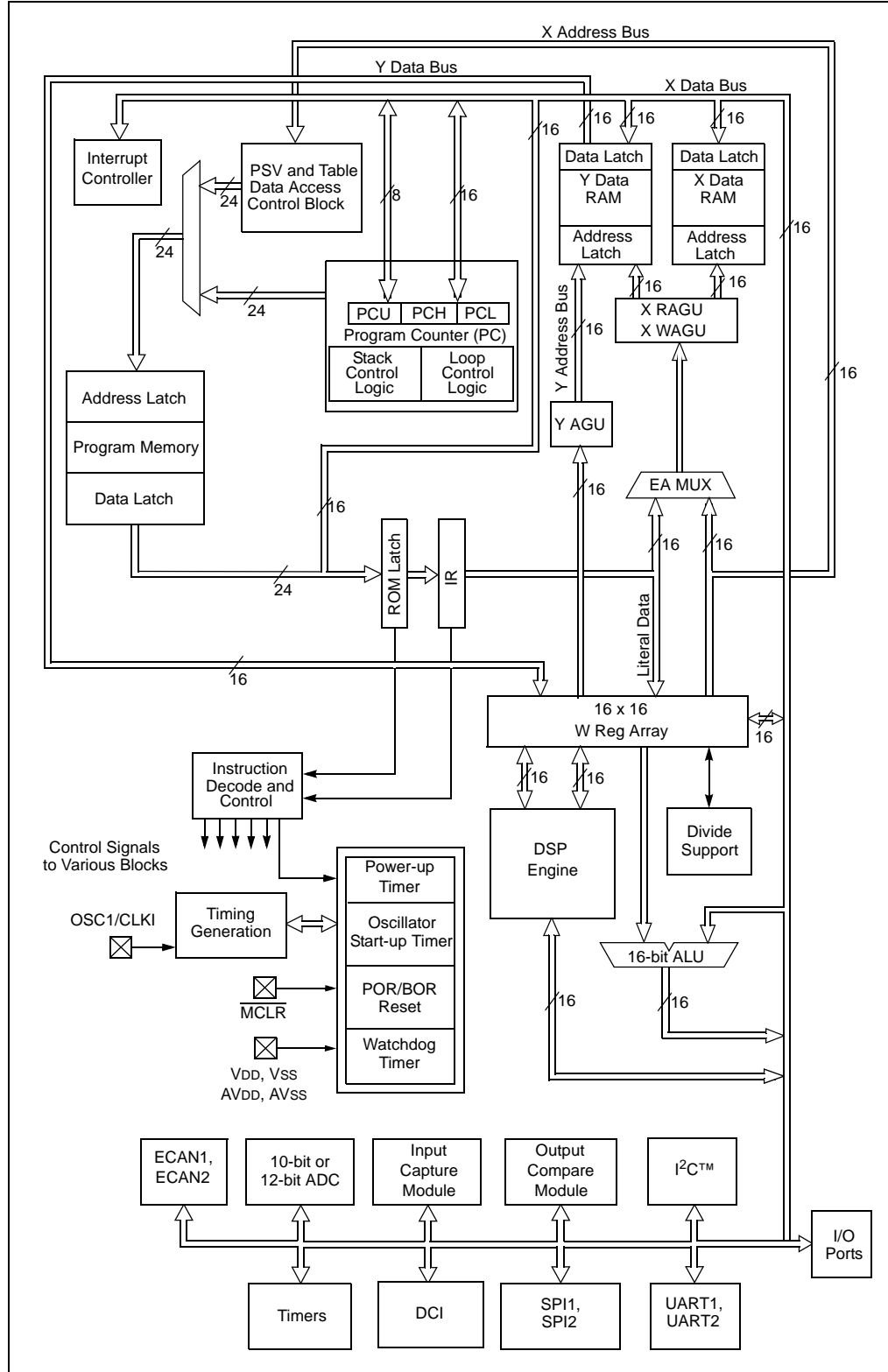

## 2.2 PROGRAMMER'S MODEL

The programmer's model for the dsPIC33F/PIC24H CPU is shown in [Figure 2-2](#). All registers in the programmer's model are memory mapped and can be manipulated directly using instructions. [Table 2-1](#) provides a description of each register.

**Table 2-1: Programmer's Model Register Descriptions**

Register	Description
W0 through W15	Working register array
ACCA, ACCB	40-bit DSP Accumulators
PC	23-bit PC
SR	ALU and DSP Engine Status register
SPLIM	Stack Pointer Limit Value register
TBLPAG	Table Memory Page Address register
PSVPAG	Program Space Visibility Page Address register
RCOUNT	REPEAT Loop Count register
DCOUNT	DO Loop Count register
DOSTART	DO Loop Start Address register
DOEND	DO Loop End Address register
CORCON	Contains DSP Engine and DO Loop control bits

In addition to the registers contained in the programmer's model, the dsPIC33F/PIC24H contains control registers for modulo addressing, bit-reversed addressing and interrupts. These registers are described in the subsequent sections in this document. All registers associated with the programmer's model are memory mapped as shown in [Table 2-3](#).

# dsPIC33F/PIC24H Family Reference Manual

Figure 2-2: Programmer's Model

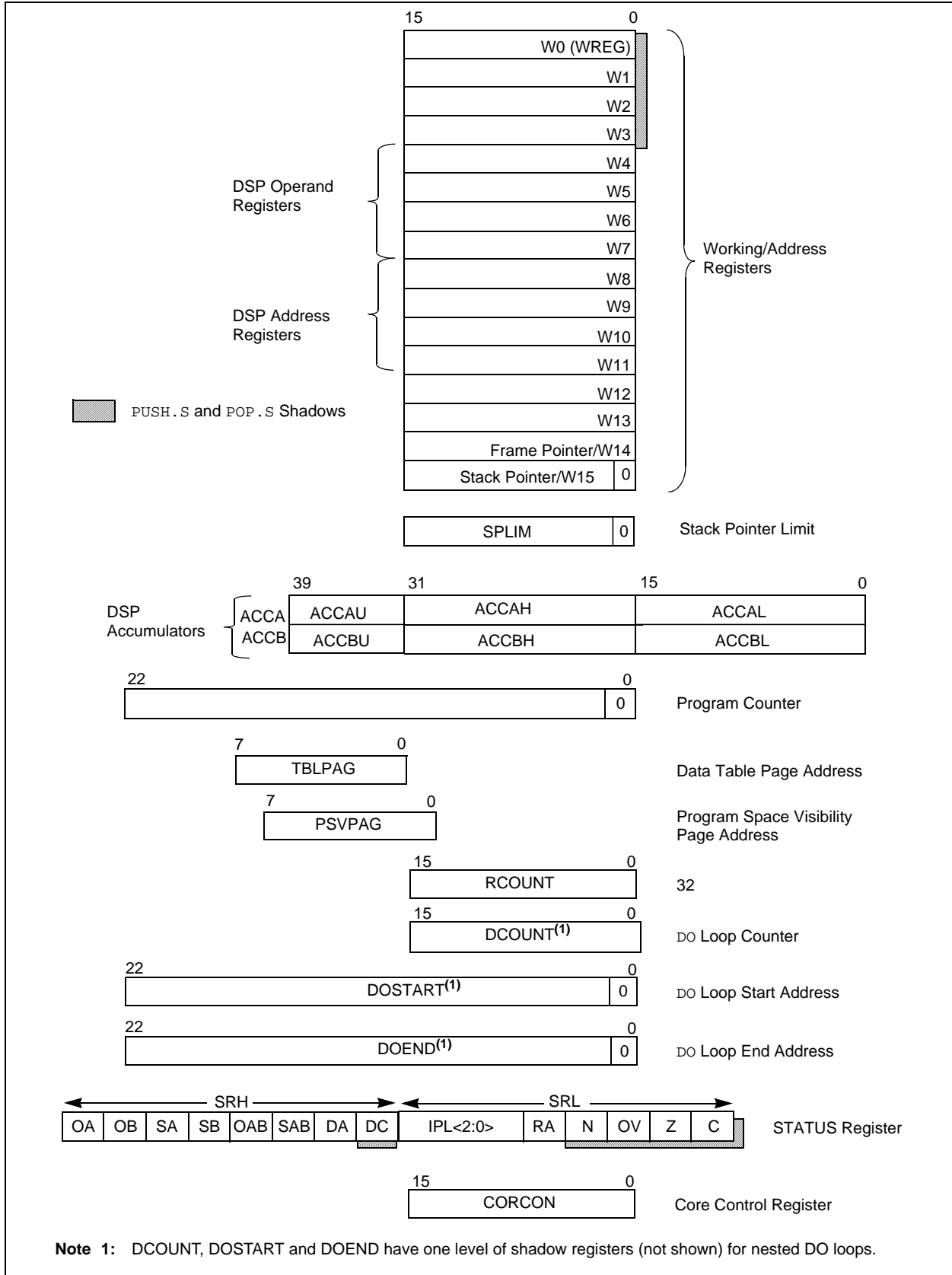

## 2.2.1 Working Register Array

The 16 working (W) registers can function as data, address or address offset registers. The function of a W register is determined by the addressing mode of the instruction that accesses it.

The dsPIC33F/PIC24H instruction set can be divided into two instruction types:

- Register instructions
- File register instructions

### 2.2.1.1 REGISTER INSTRUCTIONS

Register instructions can use each W register as a data value or an address offset value, as shown in [Example 2-1](#).

#### Example 2-1: Register Instructions

```
MOV    W0, W1      ; move contents of W0 to W1
MOV    W0, [W1]    ; move W0 to address contained in W1
ADD    W0, [W4], W5 ; add contents of W0 to contents pointed
                    ; to by W4. Place result in W5.
```

### 2.2.1.2 FILE REGISTER INSTRUCTIONS

File register instructions operate on a specific memory address contained in the instruction opcode and W0 register. W0 is a special working register used in file register instructions. Working registers W1-W15 cannot be specified as target registers in file register instructions.

The file register instructions provide backward compatibility with existing PIC<sup>®</sup> MCU devices that have only one W register. The label “WREG” is used in the assembler syntax to denote W0 in a file register instruction, as shown in [Example 2-2](#).

#### Example 2-2: File Register Instructions

```
MOV    WREG, 0x0100 ; move contents of W0 to address 0x0100
ADD    0x0100, WREG ; add W0 to address 0x0100, store in W0
```

**Note:** Refer to the “16-bit MCU and DSC Programmer’s Reference Manual” (DS70157), for complete descriptions of addressing modes and instruction syntax.

### 2.2.1.3 W REGISTER MEMORY MAPPING

Since the W registers are memory mapped, it is possible to access a W register in a file register instruction, as shown in [Example 2-3](#).

#### Example 2-3: Accessing W Register in File Register Instruction

```
MOV    0x0004, W10 ; equivalent to MOV W2, W10
```

where:  
0x0004 is the memory address of W2

Further, it is also possible to execute an instruction that uses a W register as both an address pointer and operand destination, as shown in [Example 2-4](#).

#### Example 2-4: W Register Used as Address Pointer and Operand Destination

```
MOV    W1, [W2++]
```

where:  
W1 = 0x1234  
W2 = 0x0004 ; [W2] addresses W2

In [Example 2-4](#), the contents of W2 are 0x0004. As W2 is used as an address pointer, it points to location 0x0004 in memory. W2 is also mapped to this address in memory. Even though this is an unlikely event, it is impossible to detect until run time. The dsPIC33F/PIC24H CPU ensures that the data write dominates, resulting in W2 = 0x1234 in this example.

## 2.2.1.4 W REGISTERS AND BYTE MODE INSTRUCTIONS

The byte instructions, which target the W register array, only affect the Least Significant Byte (LSB) of the target register. As the working registers are memory mapped, the LSB and Most Significant Byte (MSB) can be manipulated through byte wide data memory space access.

## 2.2.2 Shadow Registers

Many of the registers in the programmer's model have an associated shadow register, as shown in [Figure 2-2](#). None of the shadow registers are accessible directly. There are two types of shadow registers:

- Used by `PUSH.S` and `POP.S` instructions
- Used by `DO` instruction

### 2.2.2.1 PUSH.S AND POP.S SHADOW REGISTERS

The `PUSH.S` and `POP.S` instructions are useful for fast context save/restore during a function call or Interrupt Service Routine (ISR). The `PUSH.S` instruction transfers the following register values into their respective shadow registers:

- W0...W3
- SR (N, OV, Z, C, DC bits only)

The `POP.S` instruction restores the values from the shadow registers into these register locations. [Example 2-5](#) shows a code example using the `PUSH.S` and `POP.S` instructions.

#### Example 2-5: PUSH.S and POP.S Instructions

```
MyFunction:
    PUSH.S           ; Save W registers, MCU status
    MOV    #0x03,W0  ; load a literal value into W0
    ADD   RAM100     ; add W0 to contents of RAM100
    BTSC  SR,#Z      ; is the result 0?
    BSET  Flags,#IsZero ; Yes, set a flag
    POP.S           ; Restore W regs, MCU status
    RETURN
```

The `PUSH.S` instruction overwrites the contents that are previously saved in the shadow registers. The shadow registers are only one level in depth. Therefore, care must be taken if the shadow registers are to be used for multiple software tasks.

The user-assigned application must ensure that any task using the shadow registers are not interrupted by a higher priority task that also uses the shadow registers. If the higher priority task is allowed to interrupt the lower priority task, the contents of the shadow registers saved in the lower priority task are overwritten by the higher priority task.

### 2.2.2.2 DO LOOP SHADOW REGISTERS

The following registers are automatically saved in shadow registers when a `DO` instruction is executed:

- `DOSTART`
- `DOEND`
- `DCOUNT`

The `DO` shadow registers are one level in depth, permitting two loops to be automatically nested. Refer to [2.9.2.2 “DO Loop Nesting”](#), for more details on `DO` loop nesting.

## 2.2.3 Uninitialized W Register Reset

The W register array (with the exception of W15) is cleared during all resets and is considered uninitialized until written to. An attempt to use an uninitialized register as an address pointer will reset the device.

A word write must be performed to initialize a W register. A byte write will not affect the initialization detection logic.



## 2.3 SOFTWARE STACK POINTER

The W15 register serves as a dedicated Software Stack Pointer (SSP) and is automatically modified by exception processing, subroutine calls and returns. However, W15 can be referenced by any instruction in the same manner as all other W registers. This simplifies reading, writing and manipulating of the Stack Pointer (SP). For example, creating stack frames.

**Note:** To protect against misaligned stack access, W15<0> is set to '0' by the hardware.

W15 is initialized to 0x0800 during all resets. This address ensures that the SP points to valid RAM in all dsPIC33F/PIC24H devices and permits stack availability for non-maskable trap exceptions. These can occur before the SP is initialized by the user-assigned application software. The user can reprogram the SP during initialization to any location within data space.

The SP always points to the first available free word and fills the software stack, working from lower toward higher addresses. Figure 2-3 shows how it pre-decrements for a stack pop (read) and post-increments for a stack push (writes).

When the PC is pushed onto the stack, the PC<15:0> bits are pushed onto the first available stack word, and then PC<22:16> bits are pushed onto the second available stack location. For a PC push during any CALL instruction, the MSB of the PC is zero-extended before the push, as shown in Figure 2-3. During exception processing, the MSB of the PC is concatenated with the lower eight bits of the CPU status register, SR. This allows the contents of SRL to be preserved automatically during interrupt processing.

**Figure 2-3: Stack Operation for a CALL Instruction**

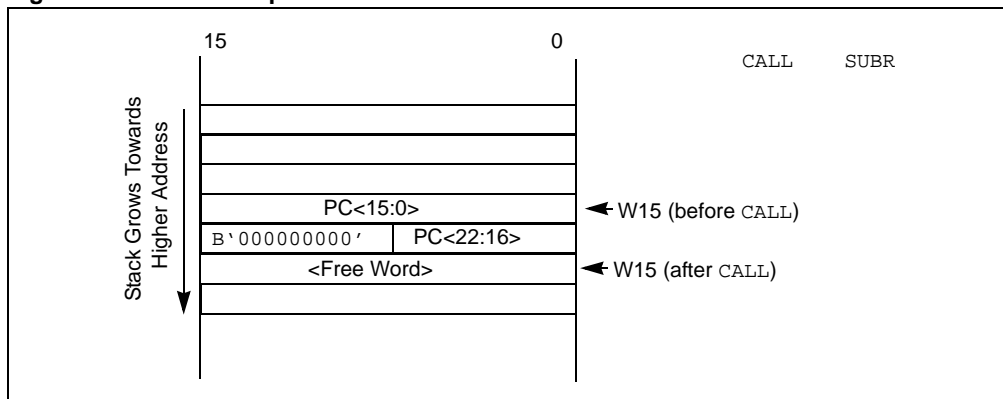

### 2.3.1 Software Stack Examples

The software stack is manipulated using the PUSH and POP instructions. The PUSH and POP instructions are the equivalent of a MOV instruction with W15 used as the destination pointer. The contents of W0 can be pushed onto the stack as shown in Example 2-6.

**Example 2-6: Software Stack Example**

```
PUSH W0
This syntax is equivalent to:
MOV W0, [W15++]
The contents of the top-of-stack can be returned to W0 by:
POP W0
This syntax is equivalent to:
MOV [--W15], W0
```

Figure 2-4 through Figure 2-7 show examples of how the software stack is used. Figure 2-4 shows the software stack at device initialization. W15 has been initialized to 0x0800. This example assumes the values 0x5A5A and 0x3636 have been written to W0 and W1, respectively. The stack is pushed for the first time in Figure 2-5 and the value contained in W0 is copied to the stack. W15 is automatically updated to point to the next available stack location (0x0802). In Figure 2-6, the contents of W1 are pushed onto the stack. Figure 2-7 shows how the stack is popped and the Top-of-Stack (TOS) value (previously pushed from W1) is written to W3.

**Figure 2-4: Stack Pointer at Device Reset**

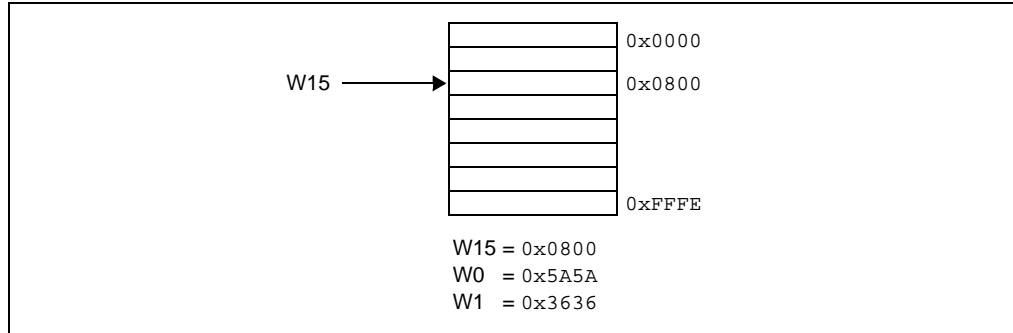

**Figure 2-5: Stack Pointer After the First PUSH Instruction**

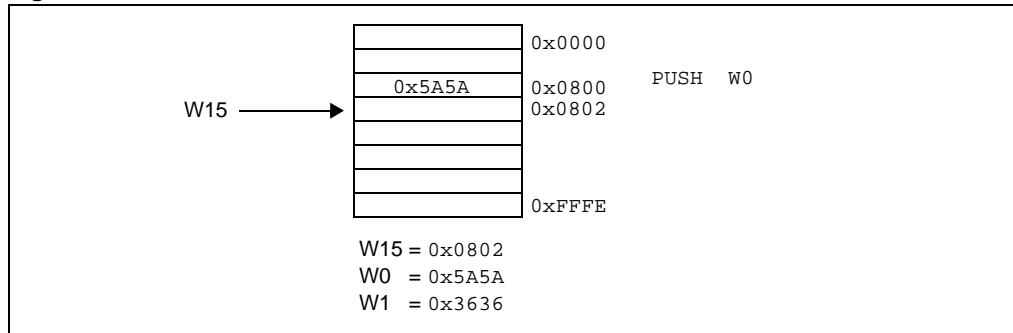

**Figure 2-6: Stack Pointer After the Second PUSH Instruction**

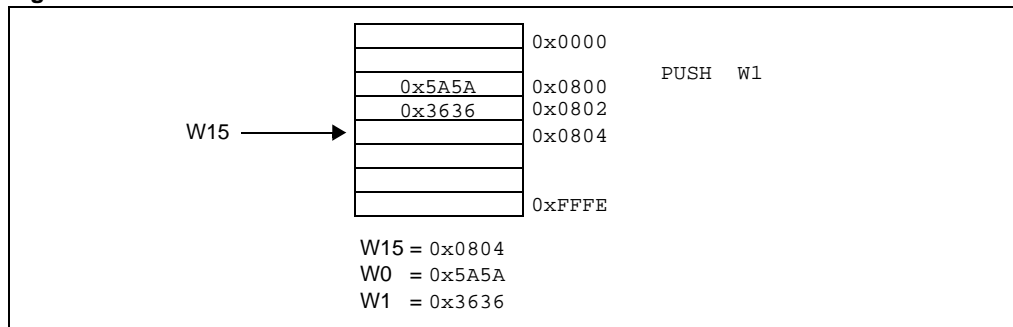

**Figure 2-7: Stack Pointer After a POP Instruction**



### 2.3.2 W14 Software Stack Frame Pointer

A frame is a user-defined section of memory in the stack that is used by a single subroutine. Working register W14 can be used as a stack frame pointer with the `LNK` (link) and `ULNK` (unlink) instructions. W14 can be used in a normal working register by instructions when it is not used as a frame pointer.

For software examples that use W14 as a stack frame pointer, refer to the “16-bit MCU and DSC Programmer’s Reference Manual” (DS70157).

### 2.3.3 Stack Pointer Overflow

The Stack Pointer Limit register (SPLIM) specifies the size of the stack buffer. The SPLIM register is a 16-bit register, but SPLIM<0> is set to '0' because all stack operations must be word-aligned.

The stack overflow check is not enabled until a word write to the SPLIM register occurs. After this time it can only be disabled by a device Reset. All effective addresses generated using W15 as a source or destination are compared against the value in SPLIM. If the contents of the Stack Pointer (W15) exceed the contents of the SPLIM register by 2, and a Push operation is performed, a stack error trap occurs on a subsequent Push operation. Thus, for example, if it is desirable to cause a stack error trap when the stack grows beyond address 0x2000 in RAM, initialize the SPLIM register with the value 0x1FFE.

**Note:** A stack error trap can be caused by any instruction that uses the contents of the W15 register to generate an Effective Address (EA). Thus, if the contents of W15 are greater than the contents of the SPLIM register by 2, and a `CALL` instruction is executed, or if an interrupt occurs, a stack error trap is generated.

If stack overflow checking is enabled, a stack error trap also occurs, if the W15 effective address calculation wraps over the end of data space (0xFFFF).

**Note:** A write to the SPLIM register should not be followed by an indirect read operation using W15.

Refer to **Section 6. "Interrupts"** (DS70184), for more details on stack error traps.

### 2.3.4 Stack Pointer Underflow

The stack is initialized to 0x0800 during a Reset. A stack error trap is initiated, if the Stack Pointer address is less than 0x0800.

**Note:** Locations in data space between 0x0000 and 0x07FF are, in general, reserved for core and peripheral Special Function Registers (SFRs).

## 2.4 CPU REGISTER DESCRIPTIONS

### 2.4.1 CPU Status Register: SR

The dsPIC33F/PIC24H CPU has a 16-bit Status Register (SR). A detailed description of the CPU Status Register is shown in [Register 2-1](#). The LSB of this register is referred to as the SRL (Status Register, Lower Byte). The MSB is referred to as SRH (Status Register, Higher Byte).

The SRL register contains all of the MCU ALU operation Status flags, the CPU Interrupt Priority Level Status bits (IPL<2:0>), and the REPEAT Loop Active Status bit, RA (SR<4>). During exception processing, SRL is concatenated with the MSB of the PC, to form a complete word value, which is then stacked.

The SRH register contains:

- The DSP Adder/Subtractor status bits
- The DO loop active bit, DA (SR<9>)
- The Digit Carry bit, DC (SR<8>)

The SR register bits are readable/writable with the following exceptions:

- The DA bit (SR<8>) is read-only
- The RA bit (SR<4>) is read-only
- The OA, OB (SR<15:14>) and OAB (SR<11>) bits are read-only and can only be modified by the DSP engine hardware
- The SA, SB (SR<13:12>) and SAB (SR<10>) bits are read- and clear-only, and can only be set by the DSP engine hardware. Once set, they remain set until cleared by the user-assigned application, irrespective of the results from any subsequent DSP operations.

**Note 1:** Clearing the SAB bit also clears both the SA and SB bits.

**2:** A description of the SR bits affected by each instruction is provided in the “16-bit MCU and DSC Programmer’s Reference Manual” (DS70157).

### 2.4.2 Core Control Register: CORCON

The CORCON register contains bits that control the operation of the DSP multiplier and DO loop hardware. The CORCON register contains the IPL3 status bit, which is concatenated with IPL<2:0> (SR<7:5>), to form the CPU Interrupt Priority Level (IPL). A detailed description of the CORCON register is provided in [Register 2-2](#).

## Register 2-1: SR: CPU Status Register

R-0	R-0	R/C-0	R/C-0	R-0	R/C-0	R-0	R/W-0
OA	OB	SA <sup>(1)</sup>	SB <sup>(2)</sup>	OAB	SAB <sup>(3)</sup>	DA	DC
bit 15						bit 8	

R/W-0 <sup>(4,5)</sup>	R/W-0 <sup>(4,5)</sup>	R/W-0 <sup>(4,5)</sup>	R-0	R/W-0	R/W-0	R/W-0	R/W-0
IPL<2:0>			RA	N	OV	Z	C
bit 7						bit 0	

<b>Legend:</b>	C = Clearable bit	U = Unimplemented bit, read as '0'
R = Readable bit	W = Writable bit	'0' = Bit is cleared
-n = Value at POR	'1' = Bit is set	x = Bit is unknown

- bit 15      **OA:** Accumulator A Overflow Status bit  
             1 = Accumulator A has overflowed  
             0 = Accumulator A has not overflowed
- bit 14      **OB:** Accumulator B Overflow Status bit  
             1 = Accumulator B has overflowed  
             0 = Accumulator B has not overflowed
- bit 13      **SA:** Accumulator A Saturation 'Sticky' Status bit<sup>(1)</sup>  
             1 = Accumulator A is saturated or has been saturated at some time  
             0 = Accumulator A is not saturated
- bit 12      **SB:** Accumulator B Saturation 'Sticky' Status bit<sup>(2)</sup>  
             1 = Accumulator B is saturated or has been saturated at some time  
             0 = Accumulator B is not saturated
- bit 11      **OAB:** OA || OB Combined Accumulator Overflow Status bit  
             1 = Accumulators A or B have overflowed  
             0 = Neither Accumulators A or B have overflowed
- bit 10      **SAB:** SA || SB Combined Accumulator 'Sticky' Status bit<sup>(3)</sup>  
             1 = Accumulators A or B are saturated or have been saturated at some time  
             0 = Neither Accumulator A or B are saturated
- bit 9        **DA:** DO Loop Active bit  
             1 = DO loop in progress  
             0 = DO loop not in progress
- bit 8        **DC:** MCU ALU Half Carry/Borrow bit  
             1 = A carry-out from the 4th low order bit (for byte-sized data) or 8th low order bit (for word-sized data) of the result occurred  
             0 = No carry-out from the 4th low order bit (for byte-sized data) or 8th low order bit (for word-sized data) of the result occurred

- Note 1:** The SA bit can be read or cleared (not set).  
**Note 2:** The SB bit can be read or cleared (not set).  
**Note 3:** The SAB bit can be read or cleared (not set). Clearing this bit clears SA and SB.  
**Note 4:** The IPL<2:0> bits are concatenated with the IPL<3> bit (CORCON<3>) to form the CPU Interrupt Priority Level. The value in parentheses indicates the IPL, if IPL<3> = 1. User interrupts are disabled when IPL<3> = 1.  
**Note 5:** The IPL<2:0> status bits are read only when NSTDIS = 1 (INTCON1<15>).

# dsPIC33F/PIC24H Family Reference Manual

---

## Register 2-1: SR: CPU Status Register (Continued)

bit 7-5	<b>IPL&lt;2:0&gt;</b> : CPU Interrupt Priority Level Status bits <sup>(4,5)</sup> 111 = CPU Interrupt Priority Level is 7 (15). User interrupts disabled 110 = CPU Interrupt Priority Level is 6 (14) 101 = CPU Interrupt Priority Level is 5 (13) 100 = CPU Interrupt Priority Level is 4 (12) 011 = CPU Interrupt Priority Level is 3 (11) 010 = CPU Interrupt Priority Level is 2 (10) 001 = CPU Interrupt Priority Level is 1 (9) 000 = CPU Interrupt Priority Level is 0 (8)
bit 4	<b>RA</b> : REPEAT Loop Active bit 1 = REPEAT loop in progress 0 = REPEAT loop not in progress
bit 3	<b>N</b> : MCU ALU Negative bit 1 = Result was negative 0 = Result was non-negative (zero or positive)
bit 2	<b>OV</b> : MCU ALU Overflow bit This bit is used for signed arithmetic (2's complement). It indicates an overflow of the magnitude that causes the sign bit to change state. 1 = Overflow occurred for signed arithmetic (in this arithmetic operation) 0 = No overflow occurred
bit 1	<b>Z</b> : MCU ALU Zero bit 1 = An operation that affects the Z bit has set it at some time in the past 0 = The most recent operation that affects the Z bit has cleared it (i.e., a non-zero result)
bit 0	<b>C</b> : MCU ALU Carry/Borrow bit 1 = A carry-out from the Most Significant bit (MSb) of the result occurred 0 = No carry-out from the Most Significant bit (MSb) of the result occurred

- Note 1:** The SA bit can be read or cleared (not set).  
**2:** The SB bit can be read or cleared (not set).  
**3:** The SAB bit can be read or cleared (not set). Clearing this bit clears SA and SB.  
**4:** The IPL<2:0> bits are concatenated with the IPL<3> bit (CORCON<3>) to form the CPU Interrupt Priority Level. The value in parentheses indicates the IPL, if IPL<3> = 1. User interrupts are disabled when IPL<3> = 1.  
**5:** The IPL<2:0> status bits are read only when NSTDIS = 1 (INTCON1<15>).

**Register 2-2: CORCON: Core Control Register**

U-0	U-0	U-0	R/W-0	R/W-0	R-0	R-0	R-0	
—	—	—	US	EDT <sup>(1)</sup>	DL<2:0>			
bit 15								bit 8

R/W-0	R/W-0	R/W-1	R/W-0	R/C-0	R/W-0	R/W-0	R/W-0
SATA	SATB	SATDW	ACCSAT	IPL3 <sup>(2)</sup>	PSV	RND	IF
bit 7							bit 0

<b>Legend:</b>	C = Clearable bit		
R = Readable bit	W = Writable bit	U = Unimplemented bit, read as '0'	
-n = Value at POR	'1' = Bit is set	'0' = Bit is cleared	x = Bit is unknown

- bit 15-13     **Unimplemented:** Read as '0'
- bit 12       **US:** DSP Multiply Unsigned/Signed Control bit  
1 = DSP engine multiplies are unsigned  
0 = DSP engine multiplies are signed
- bit 11       **EDT:** Early DO Loop Termination Control bit<sup>(1)</sup>  
1 = Terminate executing DO loop at end of current loop iteration  
0 = No effect
- bit 10-8     **DL<2:0>:** DO Loop Nesting Level Status bits  
111 = 7 DO loops active  
•  
•  
•  
001 = 1 DO loop active  
000 = 0 DO loop active
- bit 7        **SATA:** ACCA Saturation Enable bit  
1 = Accumulator A saturation enabled  
0 = Accumulator A saturation disabled
- bit 6        **SATB:** ACCB Saturation Enable bit  
1 = Accumulator B saturation enabled  
0 = Accumulator B saturation disabled
- bit 5        **SATDW:** Data Space Write from DSP Engine Saturation Enable bit  
1 = Data space write saturation enabled  
0 = Data space write saturation disabled
- bit 4        **ACCSAT:** Accumulator Saturation Mode Select bit  
1 = 9.31 saturation (super saturation)  
0 = 1.31 saturation (normal saturation)
- bit 3        **IPL3:** CPU Interrupt Priority Level Status bit 3<sup>(2)</sup>  
1 = CPU interrupt priority level is greater than 7  
0 = CPU interrupt priority level is 7 or less
- bit 2        **PSV:** Program Space Visibility in Data Space Enable bit  
1 = Program space visible in data space  
0 = Program space not visible in data space
- bit 1        **RND:** Rounding Mode Select bit  
1 = Biased (conventional) rounding enabled  
0 = Unbiased (convergent) rounding enabled
- bit 0        **IF:** Integer or Fractional Multiplier Mode Select bit  
1 = Integer mode enabled for DSP multiply  
0 = Fractional mode enabled for DSP multiply

**Note 1:** The EDT bit always reads as '0'.  
**Note 2:** The IPL3 bit is concatenated with the IPL<2:0> bits (SR<7:5>) to form the CPU interrupt priority level.

## 2.4.3 Other dsPIC33F/PIC24H CPU Control Registers

This section provides brief descriptions of additional registers that are associated with the dsPIC33F/PIC24H CPU. These registers are described in greater detail in other sections of the “dsPIC33F/PIC24H Family Reference Manual”.

- **TBLPAG: Table Page Register**

The TBLPAG register holds the upper eight bits of a program memory address during the table read and write operations. Table instructions are used to transfer data between program memory space and data memory space. Refer to **Section 4. “Program Memory”** (DS70203), for more details.

- **PSVPAG: Program Space Visibility Page Register**

The PSVPAG register allows the user-assigned application to map a 32 Kbytes section of the program memory space into the upper 32 Kbytes of data address space. This feature allows transparent access to constant data through dsPIC33F/PIC24H instructions that operate on data memory. The PSVPAG register selects the 32 Kbytes region of program memory space that is mapped to the data address space. Refer to **Section 4. “Program Memory”** (DS70203), for more details on the PSVPAG register.

- **MODCON: Modulo Control Register**

The MODCON register enables and configures modulo addressing (circular buffers). Refer to **Section 3. “Data Memory”** (DS70202), for more details on modulo addressing.

- **XMODSRT, XMODEND: X Modulo Start and End Address Registers**

The XMODSRT and XMODEND registers hold the start and end addresses for modulo (circular) buffers implemented in the X data memory address space. Refer to **Section 3. “Data Memory”** (DS70202), for more details on modulo addressing.

- **YMODSRT, YMODEND: Y Modulo Start and End Address Registers**

The YMODSRT and YMODEND registers hold the start and end addresses for modulo (circular) buffers implemented in the Y data memory address space. Refer to **Section 3. “Data Memory”** (DS70202), for more details on modulo addressing.

- **XBREV: X Modulo Bit-Reverse Register**

The XBREV register sets the buffer size used for bit-reversed addressing. Refer to **Section 3. “Data Memory”** (DS70202), for more details on modulo addressing.

- **DISICNT: Disable Interrupts Count Register**

The DISICNT register is used by the DISI instruction to disable interrupts of priority 1-6 for a specified number of cycles. Refer to **Section 6. “Interrupts”** (DS70184), for more details on interrupts.



## 2.5 ARITHMETIC LOGIC UNIT

The dsPIC33F/PIC24H Arithmetic Logic Unit (ALU) is 16 bits wide and is capable of addition, subtraction, single bit shifts, and logic operations. Unless otherwise mentioned, arithmetic operations are 2's complement in nature. Depending on the operation, the ALU can affect the values of these status bits in the SR register:

- Carry (C)
- Zero (Z)
- Negative (N)
- Overflow (OV)
- Digit Carry (DC)

The C and DC status bits operate as Borrow and Digit Borrow bits, respectively, for subtraction operations.

The ALU can perform 8-bit or 16-bit operations, depending on the mode of the instruction used. Data for the ALU operation can come from the W register array, or data memory, depending on the addressing mode of the instruction. Likewise, output data from the ALU can be written to the W register array or a data memory location.

Refer to the “16-bit MCU and DSC Programmer’s Reference Manual” (DS70157), for more details on the SR bits affected by each instruction, addressing modes and 8-bit/16-bit instruction modes.

**Note 1:** Byte operations use the 16-bit ALU and can produce results in excess of eight bits. However, to maintain backward compatibility with PIC MCU devices, the ALU result from all of the byte operations is written back as a byte (i.e., MSB is not modified), and the SR register is updated based only on the LSB state of the result.

**2:** All register instructions performed in Byte mode affect only the LSB of the W registers. The MSB of any W register can be modified by using file register instructions that access the memory mapped contents of the W registers.

### 2.5.1 Byte to Word Conversion

The dsPIC33F/PIC24H has two instructions that are helpful when mixing 8-bit and 16-bit ALU operations:

- The Sign-Extend (SE) instruction takes a byte value in a W register or data memory and creates a sign-extended word value that is stored in a W register.
- The Zero-Extend (ZE) instruction clears the 8 MSb of a word value in a W register or data memory and places the result in a destination W register.

## 2.6 DSP ENGINE

The DSP engine is a block of hardware that is fed with data from the W register array, but contains its own specialized result registers. The DSP engine is driven from the same instruction decoder that directs the MCU ALU. In addition, all operand Effective Addresses (EAs) are generated in the W register array. Concurrent operation with MCU instruction flow is not possible, though both the MCU ALU and DSP engine resources can be shared by all instructions in the instruction set.

The DSP engine consists of the following components:

- High-speed 17-bit by 17-bit multiplier
- Barrel shifter
- 40-bit adder/subtractor
- Two target accumulator registers
- Rounding logic with selectable modes
- Saturation logic with selectable modes

Data input to the DSP engine is derived from one of the following sources:

- Directly from the W array (registers W4, W5, W6 or W7) for dual source operand DSP instructions. Data values for the W4, W5, W6 and W7 registers are prefetched via the X and Y memory data buses
- From the X memory data bus for all other DSP instructions

Data output from the DSP engine is written to one of the following destinations:

- The target accumulator, as defined by the DSP instruction being executed
- The X memory data bus to any location in the data memory address space

The DSP engine can perform inherent accumulator-to-accumulator operations that require no additional data.

The MCU shift and multiply instructions use the DSP engine hardware to obtain their results. The X memory data bus is used for data reads and writes in these operations.

[Figure 2-8](#) shows the block diagram of the DSP engine.

<b>Note:</b> Refer to the <i>“16-bit MCU and DSC Programmer’s Reference Manual”</i> (DS70157), for detailed code examples and instruction syntax related to this section.
---

Figure 2-8: DSP Engine Block Diagram

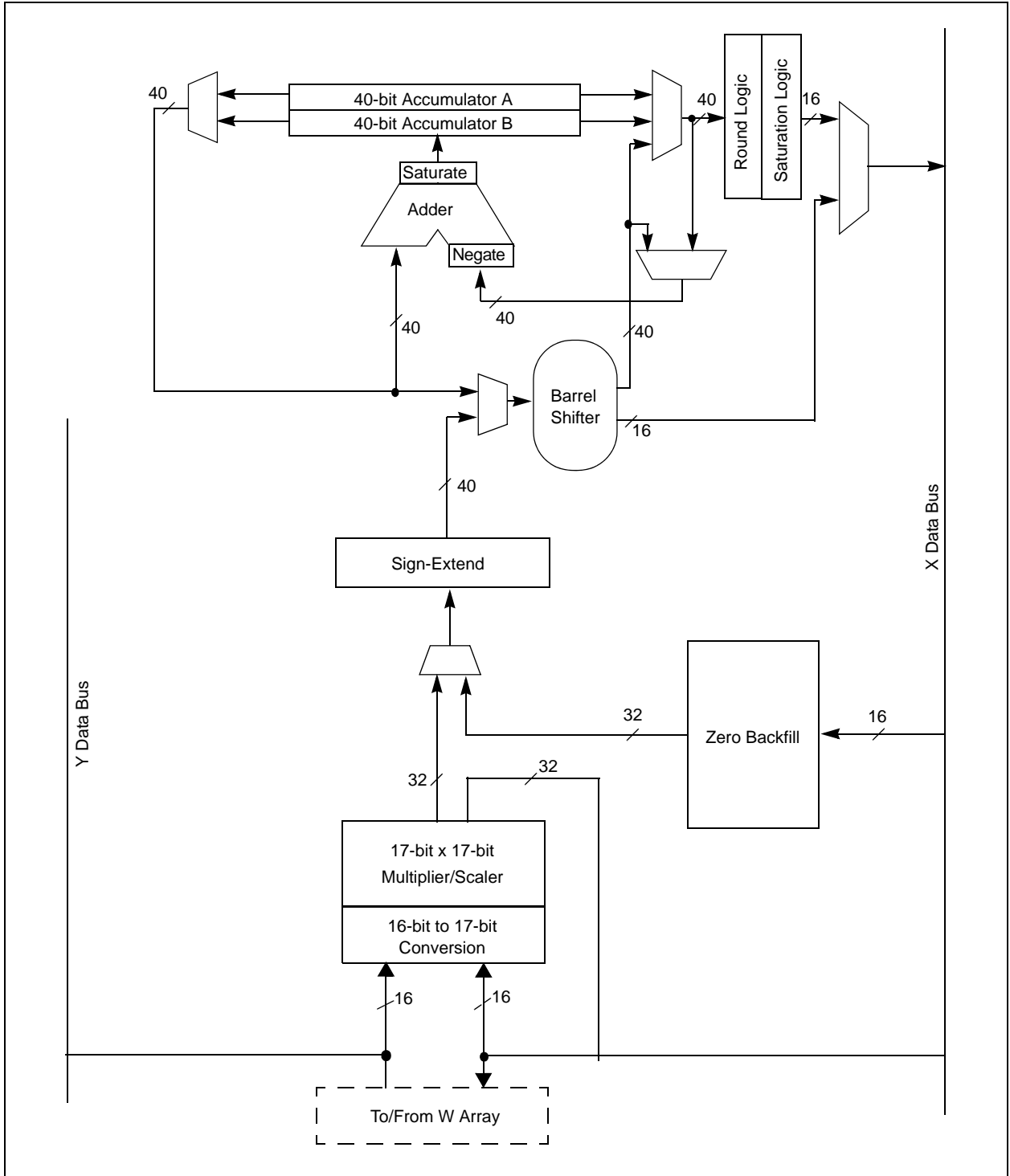

## 2.6.1 Data Accumulators

Two 40-bit data accumulators, ACCA and ACCB, are the result registers for the DSP instructions listed in [Table 2-3](#). Each accumulator is memory mapped to these three registers, where 'x' denotes the particular accumulator:

- ACCxL: ACCx<15:0>
- ACCxH: ACCx<31:16>
- ACCxU: ACCx<39:32>

For fractional operations that use the accumulators, the radix point is located to the right of bit 31. The range of fractional values that can be stored in each accumulator is  $-256.0$  to  $(256.0 - 2^{-31})$ .

For integer operations that use the accumulators, the radix point is located to the right of bit 0. The range of integer values that can be stored in each accumulator is  $-549,755,813,888$  to  $549,755,813,887$ .

## 2.6.2 Multiplier

The dsPIC33F/PIC24H CPU features a 17-bit by 17-bit multiplier (for 16-bit Signed multiplication) shared by both the MCU ALU and the DSP engine. The multiplier is capable of signed or unsigned operation and supports either 1.31 fractional (Q.31) or 32-bit integer results.

The multiplier takes in 16-bit input data and converts the data to 17 bits. Signed operands to the multiplier are sign-extended. Unsigned input operands are zero-extended. The internal 17-bit representation of data in the multiplier allows correct execution of mixed-sign and unsigned 16-bit by 16-bit multiplication operations.

The representation of data in hardware for Integer and Fractional Multiplier modes is as follows:

- Integer data is inherently represented as a signed 2's complement value, where the Most Significant bit is defined as a sign bit. Generally, the range of an N-bit 2's complement integer is  $-2^{N-1}$  to  $2^{N-1} - 1$
- Fractional data is represented as a 2's complement fraction where the MSb is defined as a sign bit and the radix point is implied to lie just after the sign bit (Q.X format). The range of an N-bit 2's complement fraction with this implied radix point is  $-1.0$  to  $(1 - 2^{1-N})$ .

The range of data in both Integer and Fractional modes is listed in [Table 2-2](#). [Figure 2-9](#) and [Figure 2-10](#) illustrate how the multiplier hardware interprets data in Integer and Fractional modes.

The Integer or Fractional Multiplier Mode Select bit (IF) in the Core Control register (CORCON<0>) determines integer/fractional operation for the instructions listed in [Table 2-3](#). The IF bit does not affect MCU multiply instructions listed in [Table 2-4](#), which are always integer operations. The multiplier scales the result one bit to the left for fractional operation. The Least Significant bits (LSBs) of the result are always cleared. The multiplier defaults to Fractional mode for DSP operations at a device Reset.

**Table 2-2: dsPIC33F/PIC24H Data Ranges**

Register Size	Integer Range	Fraction Range	Fraction Resolution
16-bit	-32768 to 32767	-1.0 to $(1.0 - 2^{-15})$ (Q.15 Format)	$3.052 \times 10^{-5}$
32-bit	-2,147,483,648 to 2,147,483,647	-1.0 to $(1.0 - 2^{-31})$ (Q.31 Format)	$4.657 \times 10^{-10}$
40-bit	-549,755,813,888 to 549,755,813,887	-256.0 to $(256.0 - 2^{-31})$ (Q.31 Format with eight guard bits)	$4.657 \times 10^{-10}$

**Figure 2-9: Integer and Fractional Representation of 0x4001**

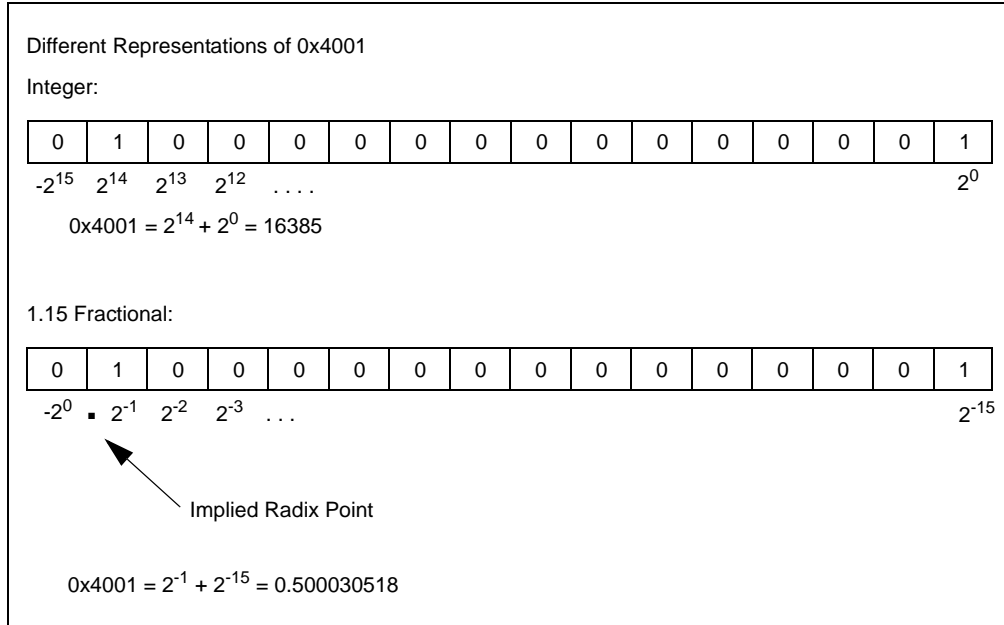

**Figure 2-10: Integer and Fractional Representation of 0xC002**

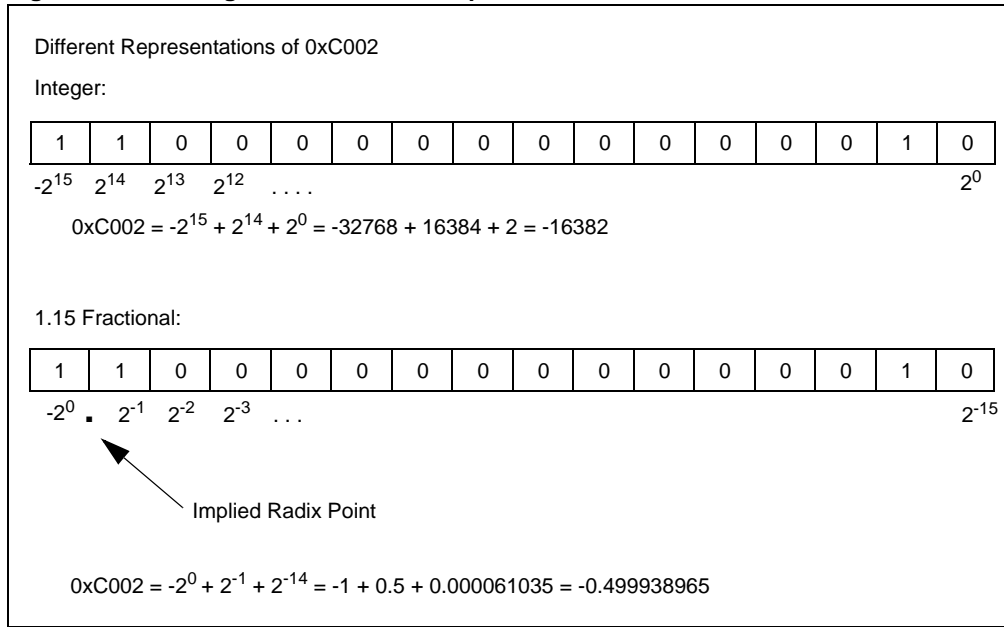

## 2.6.2.1 DSP MULTIPLY INSTRUCTIONS

The DSP instructions that use the multiplier are summarized in [Table 2-3](#).

**Table 2-3: DSP Instructions that Use the Multiplier**

DSP Instruction	Description	Algebraic Equivalent
MAC	Multiply and Add to Accumulator or Square and Add to Accumulator	$a = a + b * c$ $a = a + b^2$
MSC	Multiply and Subtract from Accumulator	$a = a - b * c$
MPY	Multiply	$a = b * c$
MPY.N	Multiply and Negate Result	$a = -b * c$
ED	Partial Euclidean Distance	$a = (b - c)^2$
EDAC	Add Partial Euclidean Distance to the Accumulator	$a = a + (b - c)^2$

**Note:** DSP instructions using the multiplier can operate in Fractional (1.15) or Integer modes.

The DSP Multiplier Unsigned/Signed Control bit (US) in the CORCON register determines whether DSP multiply instructions are signed (default) or unsigned. The US bit does not influence the MCU multiply instructions, which have specific instructions for signed or unsigned operation. If the US bit is set, the input operands for instructions shown in [Table 2-3](#) are considered as unsigned values, which are always zero-extended into the seventeenth bit of the multiplier value.

## 2.6.2.2 MCU MULTIPLY INSTRUCTIONS

The same multiplier supports the MCU multiply instructions, which include integer 16-bit signed, unsigned, and mixed sign multiplies as shown in [Table 2-4](#). All multiplications performed by the MUL instruction produce integer results. The MUL instruction can be directed to use byte-sized or word-sized operands. Byte input operands produce a 16-bit result and word input operands produce a 32-bit result to the specified register(s) in the W array.

**Table 2-4: MCU Instructions that Utilize the Multiplier**

MCU Instruction	Description
MUL/MUL.UU	Multiply two unsigned integers
MUL.SS	Multiply two signed integers
MUL.SU/MUL.US	Multiply a signed integer with an unsigned integer

**Note 1:** MCU instructions using the multiplier operate only in Integer mode.

**2:** Result of an MCU multiply is 32 bits long and is stored in a pair of W registers.

**Table 2-5: Multiplication Options**

Instruction Class	Signed x Signed	Unsigned x Unsigned	Unsigned x Signed	Signed x Unsigned
MAC (DSP Multiplication)	Yes (Integer or Fractional)	Yes (Integer or Fractional)	No	No
MUL (MCU Multiplication)	Yes (Integer only)	Yes (Integer only)	Yes (Integer only)	Yes (Integer only)

### 2.6.3 Data Accumulator Adder/Subtractor

The data accumulators have a 40-bit adder/subtractor with automatic sign extension logic for the multiplier result (if signed). It can select one of two accumulators (A or B) as its pre-accumulation source and post-accumulation destination. For the `ADD` (accumulator) and `LAC` instructions, the data to be accumulated or loaded can optionally be scaled via the barrel shifter prior to accumulation.

The 40-bit adder/subtractor can optionally negate one of its operand inputs to change the sign of the result (without changing the operands). The negate is used during multiply and subtract (`MSC`), or multiply and negate (`MPY.N`) operations.

The 40-bit adder/subtractor has an additional saturation block that controls accumulator data saturation, if enabled.

#### 2.6.3.1 ACCUMULATOR STATUS BITS

Six STATUS register bits that support saturation and overflow are located in the CPU STATUS register (SR), and are listed in [Table 2-6](#):

**Table 2-6: Accumulator Overflow and Saturation Status Bits**

Status Bit	Location	Description
OA	SR<15>	Accumulator A overflowed into guard bits (ACCA<39:32>)
OB	SR<14>	Accumulator B overflowed into guard bits (ACCB<39:32>)
SA	SR<13>	ACCA saturated (bit 31 overflow and saturation) or ACCA overflowed into guard bits and saturated (bit 39 overflow and saturation)
SB	SR<12>	ACCB saturated (bit 31 overflow and saturation) or ACCB overflowed into guard bits and saturated (bit 39 overflow and saturation)
OAB	SR<11>	OA logically ORed with OB
SAB	SR<10>	SA logically ORed with SB Clearing SAB also clears SA and SB

The OA and OB bits are read-only and are modified each time the data is passed through the accumulator add/subtract logic. When set, they indicate that the most recent operation has overflowed into the accumulator guard bits (bit 32 through bit 39). This type of overflow is not catastrophic; the guard bits preserve the accumulator data. The OAB status bit is the logical OR value of OA and OB.

The OA and OB bits, when set, can optionally generate an arithmetic error trap. The trap is enabled by setting the corresponding Overflow Trap Flag Enable bit (OVATE or OVBTE) in Interrupt Control Register 1 (INTCON1<10> or <9>) in the Interrupt controller. The trap event allows the user to perform immediate corrective action, if desired.

The SA and SB bits can be set each time data passes through the accumulator saturation logic. Once set, these bits remain set until cleared by the user-assigned application. The SAB status bit indicates the logical OR value of SA and SB. The SA and SB bits are cleared when SAB is cleared. When set, these bits indicate that the accumulator has overflowed its maximum range (bit 31 for 32-bit saturation or bit 39 for 40-bit saturation) and are saturated (if saturation is enabled).

When saturation is not enabled, the SA and SB bits indicate that a catastrophic overflow has occurred (the sign of the accumulator has been destroyed). If the Catastrophic Overflow Trap Enable bit (COVTE) in the INTCON1 register is set, SA and SB bits will generate an arithmetic error trap when saturation is disabled.

**Note 1:** Refer to [Section 6. “Interrupts” \(DS70184\)](#), for more details on arithmetic warning traps.

**2:** The SA, SB and SAB status bits can have different meaning depending on whether accumulator saturation is enabled. The Accumulator Saturation mode is controlled via the CORCON register.

## 2.6.3.2 SATURATION AND OVERFLOW MODES

The dsPIC33F/PIC24H CPU supports three saturation and overflow modes: Accumulator 39-bit Saturation, Accumulator 31-bit Saturation and Accumulator Catastrophic Overflow.

- **Accumulator 39-bit Saturation**

In this mode, the saturation logic loads the maximally positive 9.31 value (0x7FFFFFFF), or maximally negative 9.31 value (0x80000000), into the target accumulator. The SA or SB bit is set and remains set until cleared by the user-assigned application. This saturation mode is useful for extending the dynamic range of the accumulator.

To configure for this mode of saturation, set the Accumulator Saturation Mode Select bit (ACCSAT) in the CORCON register. Additionally, set the ACCA Saturation Enable bit (SATA) in the CORCON register, and/or the ACCB Saturation Enable bit (SATB) in the CORCON register to enable accumulator saturation.

- **Accumulator 31-bit Saturation**

In this mode, the saturation logic loads the maximally positive 1.31 value (0x007FFFFFFF) or maximally negative 1.31 value (0xFF800000) into the target accumulator. The SA or SB bit is set and remains set until cleared by the user. When this saturation mode is in effect, the guard bits 32 through 39 are not used except for sign-extension of the accumulator value. Consequently, the OA, OB or OAB bits in SR are never set.

To configure for this mode of overflow and saturation, the ACCSAT bit (CORCON<4>) must be cleared. Additionally, the SATA (CORCON<7>) and/or SATB (CORCON<6>) bits must be set to enable accumulator saturation.

- **Accumulator Catastrophic Overflow**

If the SATA (CORCON<7>) and/or SATB (CORCON<6>) bits are not set, then no saturation operation is performed on the accumulator, and the accumulator is allowed to overflow all the way up to bit 39 (destroying its sign). If the Catastrophic Overflow Trap Enable bit (COVTE) (INTCON1<8> in the interrupt controller) is set, a catastrophic overflow initiates an arithmetic error trap.

Accumulator saturation and overflow detection can only result from the execution of a DSP instruction that modifies one of the two accumulators via the 40-bit DSP ALU. Saturation and overflow detection does not take place when the accumulators are accessed as memory mapped registers through the MCU class instructions. Furthermore, the accumulator status bits shown in [Table 2-6](#) are not modified. However, the MCU status bits (Z, N, C, OV, DC) will be modified, depending on the MCU instruction that accesses the accumulator.

<b>Note:</b> Refer to <b>Section 6. “Interrupts”</b> (DS70184), for more details on arithmetic error traps.
---

## 2.6.3.3 DATA SPACE WRITE SATURATION

In addition to adder/subtractor saturation, writes to data space can be saturated without affecting the contents of the source accumulator. This feature allows data to be limited, while not sacrificing the dynamic range of the accumulator during intermediate calculation stages. Data space write saturation is enabled by setting the Data Space Write from DSP Engine Saturation Enable bit (SATDW) in the CORCON register. Data space write saturation is enabled by default at a device Reset.

The data space write saturation feature works with the `SAC` and `SAC.R` instructions. The value held in the accumulator is never modified when these instructions are executed. The hardware performs the following steps to obtain the saturated write result:

1. The read data is scaled based upon the arithmetic shift value specified in the instruction.
2. The scaled data is rounded (`SAC.R` only).
3. The scaled/rounded value is saturated to a 16-bit result based on the value of the guard bits. For data values greater than 0x007FFF, the data written to memory is saturated to the maximum positive 1.15 value, 0x7FFF. For input data less than 0xFF8000, data written to memory is saturated to the maximum negative 1.15 value, 0x8000.



### 2.6.3.4 ACCUMULATOR 'WRITE BACK'

The `MAC` and `MSC` instructions can optionally write a rounded version of the accumulator that is not the target of the current operation into data space memory. The write is performed across the X bus into combined X and Y address space. This accumulator write-back feature is beneficial in certain FFT and LMS algorithms.

The following addressing modes are supported by the accumulator write back hardware:

- `W13`, register direct: The rounded contents of the non-target accumulator are written into `W13` as a 1.15 fractional result
- `[W13] += 2`, register indirect with post-increment: The rounded contents of the non-target accumulator are written into the address pointed to by `W13` as a 1.15 fraction. `W13` is then incremented by 2.

### 2.6.4 Round Logic

The round logic can perform a conventional (biased) or convergent (unbiased) round function during an accumulator write (store). The Round mode is determined by the state of the Rounding Mode Select bit (`RND`) in the `CORCON` register. It generates a 16-bit, 1.15 data value, which is passed to the data space write saturation logic. If rounding is not indicated by the instruction, a truncated 1.15 data value is stored.

The two rounding modes are shown in [Figure 2-11](#). Conventional rounding takes bit 15 of the accumulator, zero-extends it and adds it to the most significant word (`msw`), excluding the guard or overflow bits (bits 16 through 31). If the least significant word (`lsw`) of the accumulator is between `0x8000` and `0xFFFF` (`0x8000` included), the `msw` is incremented. If the `lsw` of the accumulator is between `0x0000` and `0x7FFF`, the `msw` does not change. A consequence of this algorithm is that over a succession of random rounding operations, the value tends to be biased slightly positive.

Convergent (or unbiased) rounding operates in the same manner as conventional rounding except when the `lsw` equals `0x8000`. If this is the case, the `LSb` of the `msw` (bit 16 of the accumulator) is examined. If it is '1', the `msw` is incremented. If it is '0', the `msw` is not modified. Assuming that bit 16 is effectively random in nature, this scheme removes any rounding bias that may accumulate.

The `SAC` and `SAC.R` instructions store either a truncated (`SAC`) or rounded (`SAC.R`) version of the contents of the target accumulator to data memory via the X-bus (subject to data saturation). Refer to [2.6.3.3 "Data Space Write Saturation"](#), for more details.

For the `MAC` class of instructions, the accumulator write-back data path is always subject to rounding.

**Figure 2-11: Conventional and Convergent Rounding Modes**

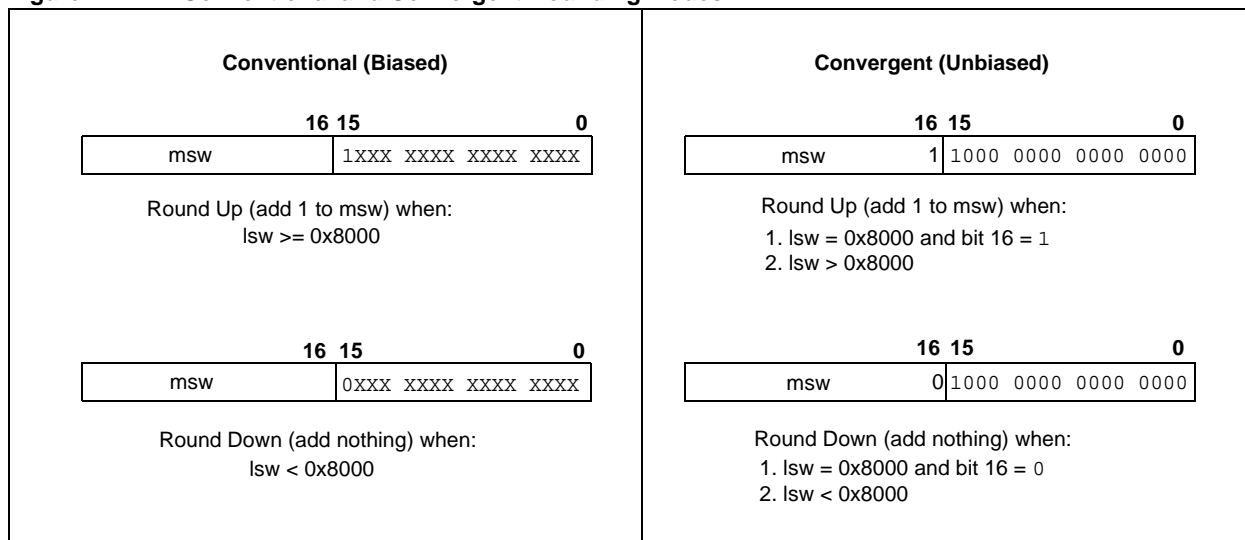

## 2.6.5 Barrel Shifter

The barrel shifter can perform up to a 16-bit arithmetic right shift, or up to a 16-bit left shift, in a single cycle. DSP or MSU instructions can use the barrel shifter for multi-bit shifts.

The shifter requires a signed binary value to determine both the magnitude (number of bits) and direction of the shift operation:

- A positive value shifts the operand right
- A negative value shifts the operand left
- A value of '0' does not modify the operand

The barrel shifter is 40 bits wide to accommodate the width of the accumulators. A 40-bit output result is provided for DSP shift operations, and a 16-bit result is provided for MCU shift operations.

Table 2-7 provides a summary of instructions that use the barrel shifter.

**Table 2-7: Instructions that Use the DSP Engine Barrel Shifter**

Instruction	Description
ASR	Arithmetic multi-bit right shift of data memory location
LSR	Logical multi-bit right shift of data memory location
SL	Multi-bit shift left of data memory location
SAC	Store DSP accumulator with optional shift
SFTAC	Shift DSP accumulator

## 2.6.6 DSP Engine Mode Selection

The operational characteristics of the DSP engine discussed in previous sections can be selected through the CPU Core Configuration register (CORCON):

- Fractional or integer multiply operation
- Conventional or convergent rounding
- Automatic saturation on/off for ACCA
- Automatic saturation on/off for ACCB
- Automatic saturation on/off for writes to data memory
- Accumulator saturation mode selection

## 2.6.7 DSP Engine Trap Events

The following arithmetic error traps can be generated for handling exceptions in the DSP engine and are selected through the Interrupt Control register (INTCON1):

- Trap on ACCA overflow enable, using OVATE (INTCON1<10>)
- Trap on ACCB overflow enable, using OVBTE (INTCON1<9>)
- Trap on catastrophic ACCA and/or ACCB overflow enable, using COVTE (INTCON1<8>)

Occurrence of the traps is indicated by the following error status bits:

- OVAERR (INTCON1<14>)
- OVBERR (INTCON1<13>)
- COVAERR (INTCON1<12>)
- COVBERR (INTCON1<11>)

An arithmetic error trap is also generated when the user-assigned application attempts to shift a value beyond the maximum allowable range ( $\pm 16$  bits) using the SFTAC instruction. This trap source cannot be disabled, and is indicated by the Shift Accumulator Error Status bit (SFTACERR) (INTCON1<7> in the Interrupt controller). The instruction will execute, but the results of the shift are not written to the target accumulator. Refer to **Section 6. "Interrupts"** (DS70184), for more details on bits in the INTCON1 register and arithmetic error traps.

## 2.7 DIVIDE SUPPORT

The dsPIC33F/PIC24H supports the following types of division operations:

- `DIVF`: 16/16 signed fractional divide
- `DIV.SD`: 32/16 signed divide
- `DIV.UD`: 32/16 unsigned divide
- `DIV.SW`: 16/16 signed divide
- `DIV.UW`: 16/16 unsigned divide

The quotient for all divide instructions is placed in working register `W0`. The remainder is placed in `W1`. The 16-bit divisor can be located in any `W` register. A 16-bit dividend can be located in any `W` register and a 32-bit dividend must be located in an adjacent pair of `W` registers.

All divide instructions are iterative operations and must be executed 18 times within a `REPEAT` loop. The developer is responsible for programming the `REPEAT` instruction. A complete divide operation takes 19 instruction cycles to execute.

The divide flow is interruptible, just like any other `REPEAT` loop. All data is restored into the respective data registers after each iteration of the loop. Therefore, the user-assigned application is responsible for saving the appropriate `W` registers in the ISR. Although they are important to the divide hardware, the intermediate values in the `W` registers have no meaning to the user-assigned application. The divide instructions must be executed 18 times in a `REPEAT` loop to produce a meaningful result.

A Divide-by-Zero error generates a math error trap. This condition is indicated by the Math Error Status bit (`DIV0ERR`) (`INTCON1<6>` in the Interrupt controller). Refer to the “16-bit MCU and DSC Programmer’s Reference Manual” (DS70157), for more details and programming examples for the divide instructions.

## 2.8 INSTRUCTION FLOW TYPES

Most instructions in the dsPIC33F/PIC24H architecture occupy a single word of program memory and execute in a single cycle. An instruction prefetch mechanism facilitates single cycle (1 Tcy) execution. However, some instructions take two or three instruction cycles to execute. Consequently, there are seven different types of instruction flow in the dsPIC<sup>®</sup> DSC architecture, which are listed below and are described in this section:

- 1 Instruction Word, 1 Instruction Cycle
- 1 Instruction Word, 2 Instruction Cycles
- 1 Instruction Word, 2 or 3 Instruction Cycles (Program Flow Changes)
- 1 Instruction Word, 3 Instruction Cycles (RETFLW, RETURN, RETLW)
- Table Read and Table Write Instructions
- 2 Instruction Words, 2 Instruction Cycles
- Address Register Dependencies

### 2.8.1 1 Instruction Word, 1 Instruction Cycle

These instructions take one instruction cycle to execute as shown in [Figure 2-12](#). Most instructions are one-word, one-cycle instructions.

**Figure 2-12: Instruction Flow: One-Word, One-Cycle**

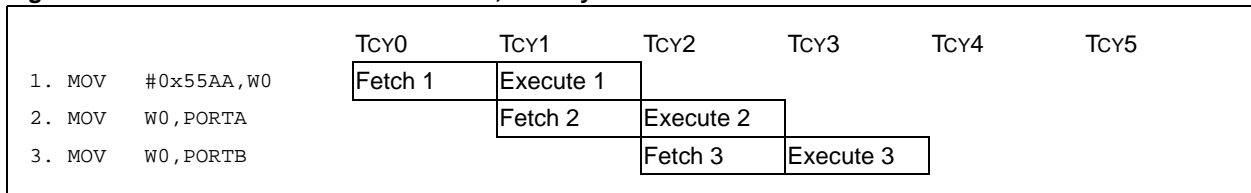

### 2.8.2 1 Instruction Word, 2 Instruction Cycles

In these instructions, there is no prefetch flush. The only instructions of this type are the MOV.D instructions (load and store double-word). Two cycles are required to complete these instructions, as shown in [Figure 2-13](#).

**Figure 2-13: Instruction Flow: One-Word, Two-Cycle (MOV.D Operation)**

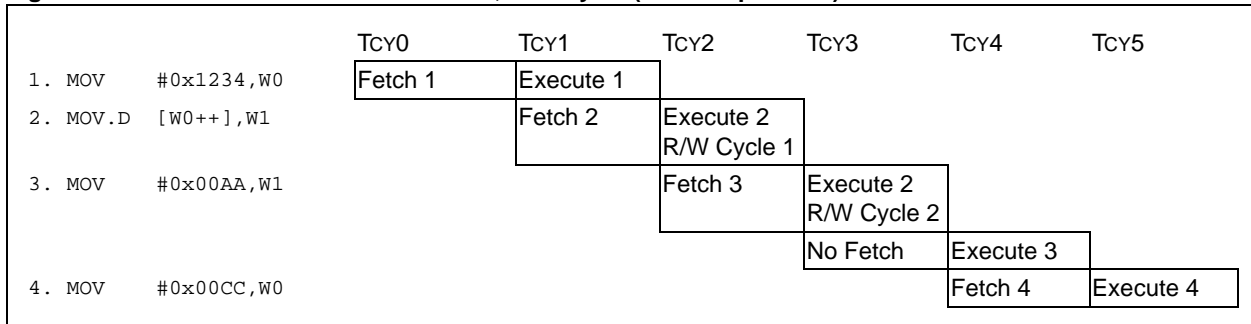

### 2.8.3 1 Instruction Word, 2 or 3 Instruction Cycles (Program Flow Changes)

These instructions include relative call and branch instructions, and skip instructions. When an instruction changes the PC (other than to increment it), the program memory prefetch data must be discarded. This makes the instruction take two effective cycles to execute, as shown in Figure 2-14.

Figure 2-14: Instruction Flow: One-Word, Two-Cycle (Program Flow Change)

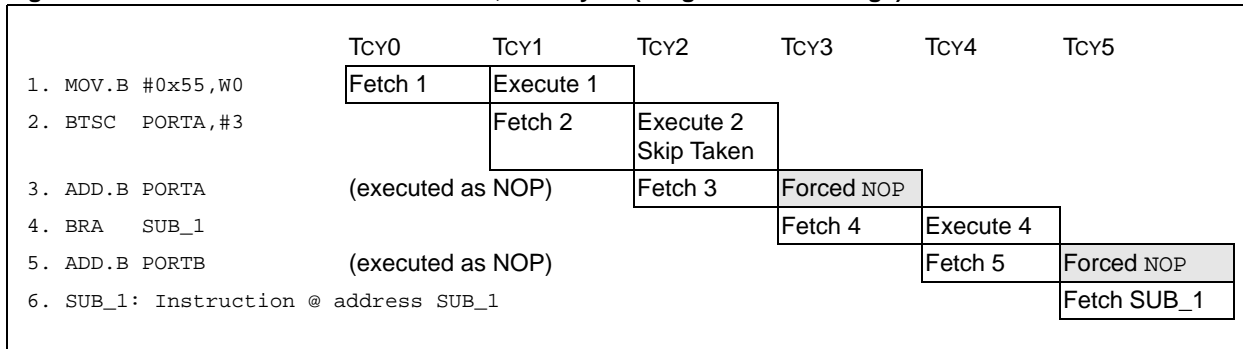

Three cycles are required when a two-word instruction is skipped. In this case, the program memory prefetch data is discarded and the second word of the two-word instruction is fetched. Figure 2-15 shows the second word of the instruction is executed as a NOP.

Figure 2-15: Instruction Flow: One-Word, Three-Cycle (Two-Word Instruction Skipped)

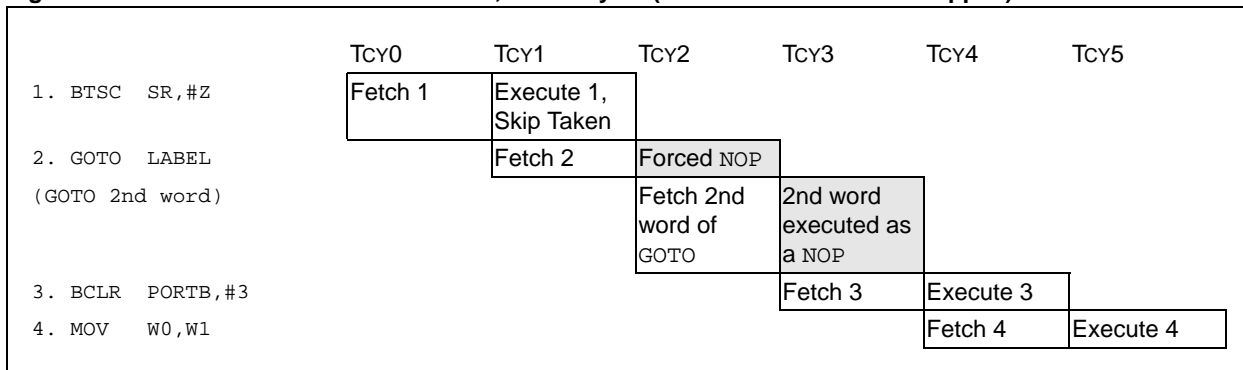

### 2.8.4 1 Instruction Word, 3 Instruction Cycles (RETFIE, RETURN, RETLW)

Figure 2-16 shows the RETFIE, RETURN and RETLW instructions, used to return from a subroutine call or an ISR, take three instruction cycles to execute.

Figure 2-16: Instruction Flow: One-Word, Three-Cycle (RETURN, RETFIE, RETLW)

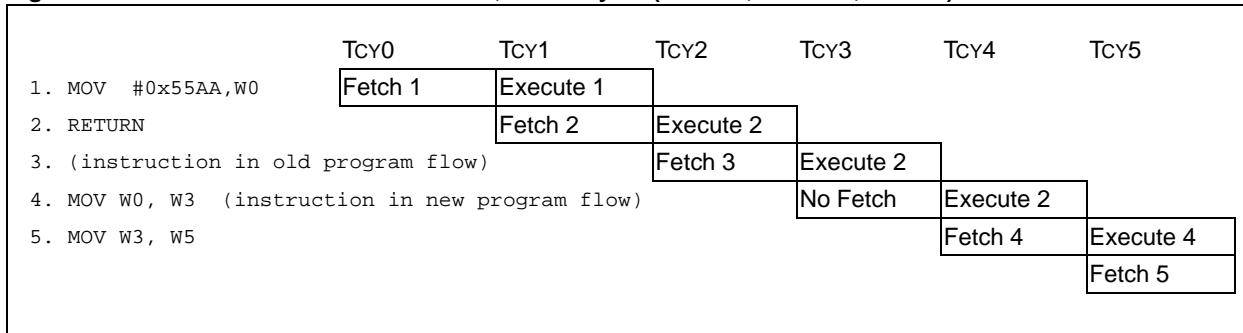

## 2.8.5 Table Read/Write Instructions

These instructions suspend fetching to insert a read or write cycle to the program memory. Figure 2-17 shows the instruction fetched while executing the table operation is saved for one cycle and executed in the cycle immediately after the table operation.

**Figure 2-17: Instruction Pipeline Flow: Table Operations**

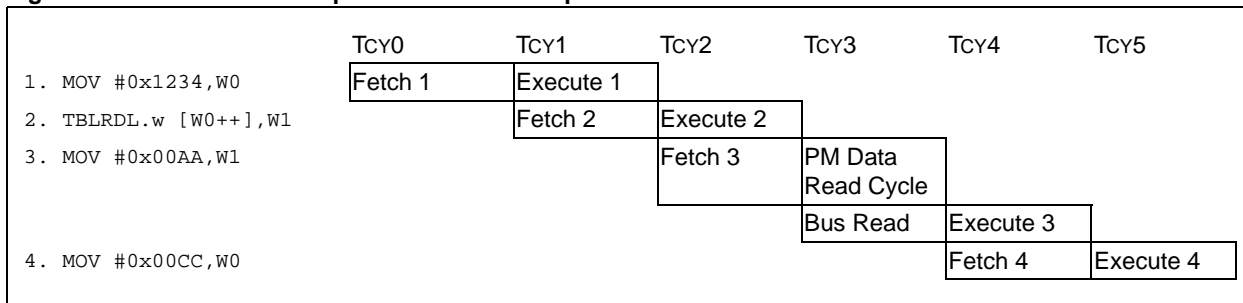

## 2.8.6 2 Instruction Words, 2 Instruction Cycles

In these instructions, the fetch after the instruction contains data. This results in a two-cycle instruction, as shown in Figure 2-18. The second word of a two-word instruction is encoded so that it executes as a NOP if it is fetched by the CPU, when the CPU did not first fetch the first word of the instruction. This is important when a two-word instruction is skipped by a skip instruction (refer to Figure 2-15).

**Figure 2-18: Instruction Pipeline Flow: Two-Word, Two-Cycle**

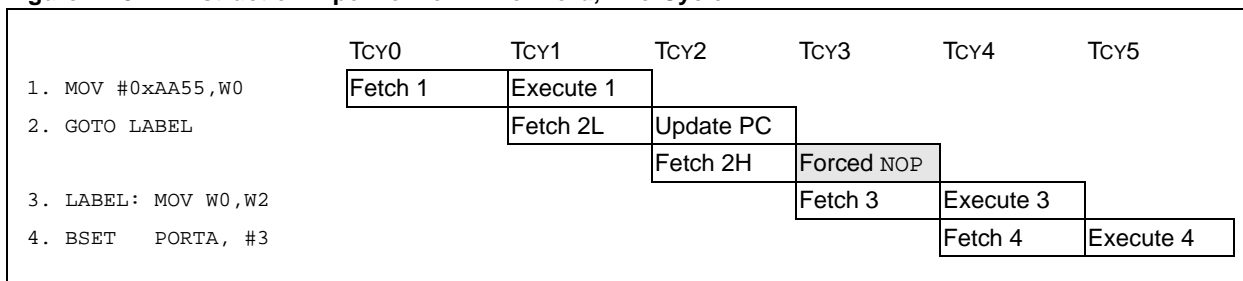

## 2.8.7 Address Register Dependencies

These are instructions that are subject to a stall due to data address dependency between the X-data space read and write operations. An additional cycle is inserted to resolve the resource conflict, and is discussed in 2.10 “Address Register Dependencies”.

**Figure 2-19: Instruction Pipeline Flow: One-Word, One-Cycle (With Instruction Stall)**

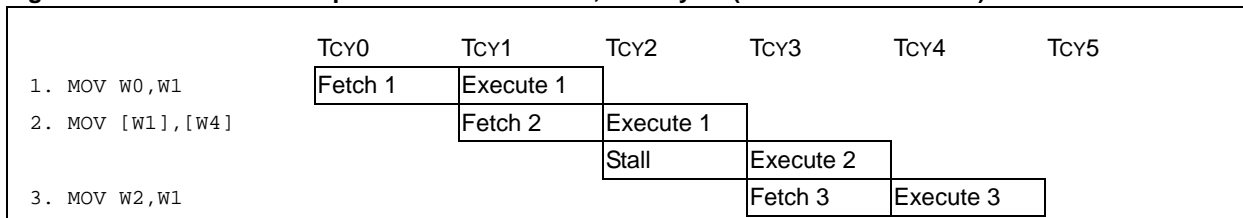

**Note:** If the RETURN instruction is placed at the end of the program memory, the illegal address error trap will be generated by the device during the run-time. This is due to the prefetch operation that will try to preload the next two instructions from the memory location, which in this case do not exist. The solution is to leave two extra instruction words available after the RETURN instruction, so that the compiler can place NOP and RESET instructions at the end of the program memory.

## 2.9 LOOP CONSTRUCTS

The dsPIC33F/PIC24H CPU supports both REPEAT and DO instruction constructs to provide unconditional automatic program loop control. The REPEAT instruction implements a single instruction program loop. The DO instruction implements a multiple instruction program loop. Both instructions use control bits within the CPU Status register (SR) to temporarily modify the CPU operation.

### 2.9.1 REPEAT Loop Construct

The REPEAT instruction causes the instruction that follows it to be repeated a specified number of times. A literal value contained in the instruction or a value in one of the W registers can be used to specify the REPEAT count value. The W register option enables the loop count to be a software variable.

An instruction in a REPEAT loop is executed at least once. The number of iterations for a REPEAT loop is the 14-bit literal value + 1, or Wn + 1.

The syntax for the two forms of the REPEAT instruction is as follows:

#### Example 2-7: REPEAT Instruction Syntax

```
REPEAT #lit14          ; RCOUNT <-- lit14
(Valid target Instruction)

or

REPEAT Wn              ; RCOUNT <-- Wn
(Valid target Instruction)
```

#### 2.9.1.1 REPEAT OPERATION

The loop count for REPEAT operations is held in the 14-bit REPEAT Loop Counter register (RCOUNT), which is memory mapped. The RCOUNT register is initialized by the REPEAT instruction. The REPEAT instruction sets the REPEAT Loop Active bit (RA) in the SR register to '1', if the RCOUNT is a non-zero value.

The RA bit is read-only and cannot be modified through software. For REPEAT loop count values greater than '0', the PC is not incremented. Further, PC increments are inhibited until RCOUNT = 0. For an instruction flow example of a REPEAT loop, refer to Figure 2-20.

For a loop count value equal to '0', REPEAT has the effect of a NOP and the RA bit (SR<4>) is not set. The REPEAT loop is essentially disabled before it begins, allowing the target instruction to execute only once while prefetching the subsequent instruction (i.e., normal execution flow).

**Note:** The instruction immediately following the REPEAT instruction (i.e., the target instruction) is always executed at least one time, and it is always executed one time more than the value specified in the 14-bit literal or the W register operand.

Figure 2-20: REPEAT Instruction Pipeline Flow

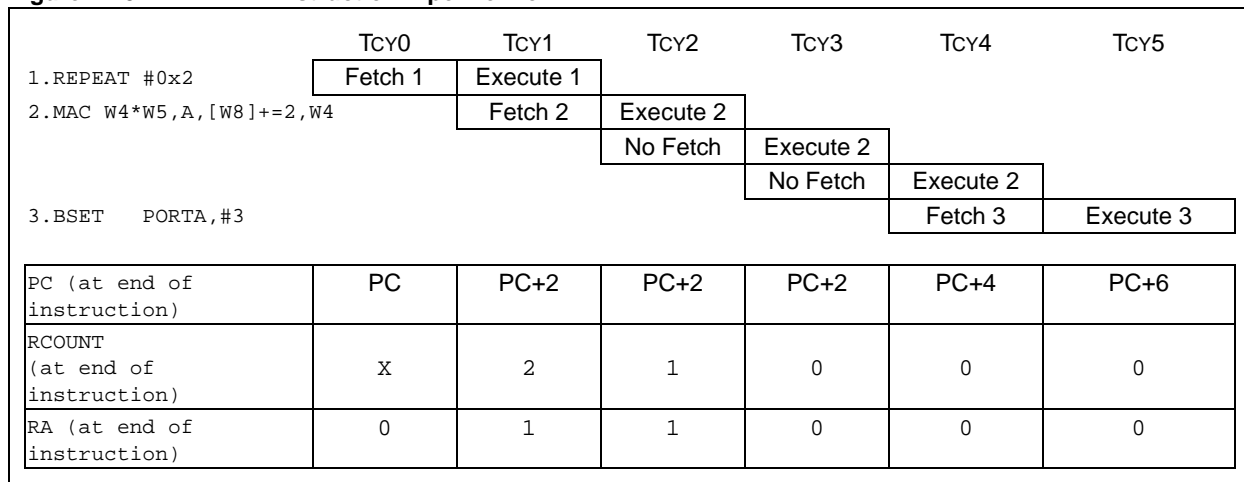

## 2.9.1.2 INTERRUPTING A REPEAT LOOP

A `REPEAT` instruction loop can be interrupted any time. The state of the RA bit is preserved on the stack during exception processing to enable the user-assigned application to execute further `REPEAT` loops from within any number of nested interrupts. After the SRL register is stacked, the RA status bit is cleared to restore normal execution flow within the ISR.

- |   |
|---|
| <p><b>Note 1:</b> If a <code>REPEAT</code> loop has been interrupted, and an ISR is being processed, the user-assigned application must stack the <code>REPEAT</code> Count register (RCOUNT) before it executes another <code>REPEAT</code> instruction within an ISR.</p> <p><b>2:</b> If a <code>REPEAT</code> instruction is used within an ISR, the user-assigned application must unstack the RCOUNT register before it executes the <code>RETFIE</code> instruction.</p> |
|---|

Returning into a `REPEAT` loop from an ISR using the `RETFIE` instruction requires no special handling. Interrupts prefetch the repeated instruction during the third cycle of the `RETFIE` instruction. The stacked RA bit is restored when the SRL register is popped and, if set, the interrupted `REPEAT` loop is resumed.

- |  |
|--|
| <p><b>Note:</b> When the repeated instruction (target instruction in the <code>REPEAT</code> loop) accesses the data from Program Space (PS) using PSV, it will require two instruction cycles the first time it is executed after a return from an exception. Similar to the first iteration of a loop, the timing limitations do not allow the first instruction to access data residing in Program Space in a single instruction cycle.</p> |
|--|

### 2.9.1.2.1 Early Termination of a REPEAT Loop

An interrupted `REPEAT` loop can be terminated earlier than normal in the ISR by clearing the RCOUNT register in software.

## 2.9.1.3 RESTRICTIONS ON THE REPEAT INSTRUCTION

Any instruction can immediately follow a `REPEAT` except for the following:

- Program Flow Control instructions (any branch, compare and skip, subroutine calls, returns, etc.)
- Another `REPEAT` or `DO` instruction
- `DISI`, `ULNK`, `LNK`, `PWRSV` or `RESET`
- `MOV.D` instruction

- |  |
|--|
| <p><b>Note:</b> Some instructions and/or instruction addressing modes can be executed within a <code>REPEAT</code> loop, but it is not necessary to repeat all instructions.</p> |
|--|



## 2.9.2 DO Loop Construct

The `DO` instruction can execute a group of instructions that follow a specified number of times without the software overhead. The set of instructions up to and including the end address are repeated. The `DO` iteration count value for the `DO` instruction can be specified by a 14-bit literal or by the contents of a `W` register declared within the instruction. The syntax for the 14-bit literal form of the `DO` instruction is as shown in [Example 2-8](#).

### Example 2-8: Syntax for the 14-bit Literal Form of the `DO` Instruction

```
DO    #lit14,LOOP_END      ; DCOUNT <-- lit14
Instruction1
Instruction2
:
:
LOOP_END: Instruction n
```

The syntax for the `W` register declared form of the `DO` instruction is as shown in [Example 2-9](#):

### Example 2-9: Syntax for the `W` Register Declared Form of the `DO` Instruction

```
DO    Wn,LOOP_END         ; DCOUNT <-- Wn<13:0>
Instruction1
Instruction2
:
:
LOOP_END: Instruction n
```

The following features are provided in the `DO` loop construct:

- A `W` register can be used to specify the loop count, which allows the loop count to be defined at run-time
- The instruction execution order need not be sequential (i.e., there can be branches, subroutine calls, etc.)
- The loop end address need not be greater than the start address

#### 2.9.2.1 `DO` LOOP REGISTERS AND OPERATION

The number of iterations executed by a `DO` loop will be the 14-bit literal value + 1 or the `Wn` value + 1. If a `W` register is used to specify the number of iterations, the two Most Significant bits are not used to specify the loop count. The operation of a `DO` loop is similar to the `DO-WHILE` construct in the C programming language, because the instructions in the loop will always be executed at least once.

The dsPIC33F/PIC24H CPU consists of the following three registers that are associated with `DO` loops:

- The `DO` Loop Start Address register (`DOSTART`) is a 22-bit register that holds the starting address of the `DO` loop
- The `DO` Loop End Address register (`DOEND`) is a 16-bit register that holds the end address of the `DO` loop
- The `DO` Loop Counter register (`DCOUNT`) is a 16-bit register that holds the number of iterations to be executed by the loop

These registers are memory mapped and are automatically loaded by the hardware when the `DO` instruction is executed. The MSb and LSb of these registers are set to '0'. The LSb is not stored in these registers because `PC<0>` is always forced to '0'.

The `DO` Loop Active bit (`DA`) in the `SR` register indicates that a single `DO` loop (or nested `DO` loops) is active. When a `DO` instruction is executed, the `DA` bit is set, which enables the `PC` address to be compared with the `DOEND` register on each subsequent instruction cycle. When the `PC` matches the value in `DOEND`, `DCOUNT` is decremented.

If the DCOUNT register is not zero, the PC is loaded with the address contained in the DOSTART register to start another iteration of the DO loop. When DCOUNT reaches zero, the DO loop terminates.

If no other nested DO loops are in progress, the DA bit is also cleared.

**Note:** The group of instructions in a DO loop construct is always executed at least one time. The DO loop is always executed one time more than the value specified in the literal or W register operand.

## 2.9.2.2 DO LOOP NESTING

The DOSTART, DOEND and DCOUNT registers each have an associated shadow register that allows the DO loop hardware to support one level of automatic nesting. The DOSTART, DOEND and DCOUNT registers are user accessible. They can be manually saved to permit additional nesting, where required.

The DO Loop Nesting Level bits (DL<2:0>) in the CORCON register indicate the nesting level of the DO loop currently being executed. When the first DO instruction is executed, DL<2:0> is set to 'b001 to indicate that one level of the DO loop is underway. The DO Loop Active bit (DA) in the SR register is also set.

When another DO instruction is executed within the first DO loop, the DOSTART, DOEND and DCOUNT registers are transferred into the shadow registers before they are updated with the new loop values. The DL<2:0> bits are set to 'b010 to indicate that a second, nested DO loop is in progress. The DA bit (SR<9>) also remains set.

If no more than one level of DO loop nesting is required in the application, no special attention is required. However, if the user-assigned application requires more than one level of DO loop nesting, it can be achieved by saving the DOSTART, DOEND and DCOUNT registers before executing the next DO instruction. These registers should be saved whenever DL<2:0> is 'b010 or greater.

The DOSTART, DOEND and DCOUNT registers are automatically restored from their shadow registers when a DO loop terminates and DL<2:0> = 'b010.

**Note:** The DL<2:0> (CORCON<10:8>) bits are combined (logically ORed) to form the DA bit (SR<9>). If nested DO loops are being executed, the DA bit is cleared only when the loop count associated with the outermost loop expires.

## 2.9.2.3 INTERRUPTING A DO LOOP

DO loops can be interrupted at any time. If another DO loop is to be executed during the ISR, the user-assigned application must check the DL<2:0> status bits and save the DOSTART, DOEND and DCOUNT registers as required.

No special handling is required if the user-assigned application can ensure that only one level of DO loop will be executed in:

- Both background and any one ISR handler (if interrupt nesting is enabled) or
- Both background and any ISR (if interrupt nesting is disabled)

Alternatively, up to two (nested) DO loops can be executed in either background or within:

- One ISR handler (if interrupt nesting is enabled) or
- Any ISR (if interrupt nesting is disabled)

It is assumed that no DO loops are used within any trap handlers.

Returning to a DO loop from an ISR using the RETFIE instruction requires no special handling.

#### 2.9.2.4 EARLY TERMINATION OF THE DO LOOP

There are two ways to terminate a DO loop earlier than normal:

- The Early DO Loop Termination Control bit (EDT) in the CORCON register provides a means for the user-assigned application to terminate a DO loop before it completes all loops. Writing a '1' to the EDT bit forces the loop to complete the iteration underway and then terminate. If EDT is set during the next-to-last (pen-ultimate) or last instruction of the loop, one more iteration of the loop occurs. EDT always reads as a '0'; clearing it has no effect. After the EDT bit is set, the user can optionally branch out of the DO loop.
- Alternatively, the code can branch out of the loop at any point except from the last instruction, which cannot be a flow-control instruction. Although the DA bit (SR<9>) enables the DO loop hardware, it has no effect unless the address of the pen-ultimate instruction is encountered during an instruction prefetch. This is not a recommended method for terminating a DO loop.

**Note:** Exiting a DO loop without using EDT is not recommended, because the hardware will continue to check for DOEND addresses.

#### 2.9.2.5 DO LOOP RESTRICTIONS

The use of DO loops imposes restrictions such as:

- When the DOEND register can be read.
- A few instructions must not be used as the last instruction in the loop.
- Certain small loop lengths are prohibited, as listed in [Table 2-8](#) (loop length refers to the size of the block of instructions that is being repeated in the loop).

##### 2.9.2.5.1 DOEND Register Restrictions

All DO loops must contain at least two instructions because the loop termination tests are performed in the pen-ultimate instruction. REPEAT should be used for single instruction loops.

The DOEND Special Function Register (SFR), cannot be read by user software in the instruction that immediately follows either a DO instruction or a file register write operation to the DOEND SFR.

The instruction before the pen-ultimate instruction in a DO loop should not modify:

- CPU priority level governed by the CPU IPL status bits (SR<7:5>).
- Peripheral Interrupt Enable bits governed by Interrupt Enable Control registers IEC0, IEC1 and IEC2.
- Peripheral Interrupt Priority bits governed by Interrupt Priority Control registers IPC0 through IPC11.

If these restrictions are not observed, the DO loop may execute incorrectly.

##### 2.9.2.5.2 Last Instruction Restrictions

The last instruction in a DO loop should not be any of the following:

- Flow control instruction (e.g., any branch, compare and skip, GOTO, CALL, RCALL, TRAP).
- Another REPEAT or DO instruction.
- Target instruction within a REPEAT loop. This restriction implies that the one before the last instruction also cannot be a REPEAT.
- Any instruction that occupies two words in program space.
- DISI instruction.

RETURN, RETFIE and RETLW work correctly as the last instruction of a DO loop, but the user-assigned application is responsible for returning to the loop to complete it.

# dsPIC33F/PIC24H Family Reference Manual

## 2.9.2.5.3 Loop Length Restrictions

Loop length is defined as the signed offset of the last instruction from the first instruction in the DO loop. The loop length, when added to the address of the first instruction in the loop, forms the address of the last instruction of the loop. [Table 2-8](#) lists the loop lengths to avoid.

**Table 2-8: Loop Lengths to Avoid**

Loop Length	Reason to Avoid
-2	<p>Execution starts at the first instruction in the loop (i.e., at the PC address) and continues until the loop-end address (in this case [PC – 4]) is prefetched. As this is the first word of the DO instruction, it executes the DO instruction again, re-initializing the DCOUNT and prefetching [PC]. This continues forever as long as the loop end address [PC – 4] is prefetched. This value of n has the potential of creating an infinite loop (subject to a Watchdog Timer Reset).</p> <p>For example:</p> <pre> end_loop: DO #33, end_loop ;DO is a two-word instruction           NOP                ;2nd word of DO executes as a NOP           ADD W2,W3,W4       ;First instruction in DO loop([PC]) </pre>
-1	<p>Execution starts at the first instruction in the loop (i.e., at [PC]) and continues until the loop end address ([PC – 2]) is prefetched. Since the loop end address is the second word of the DO instruction, it executes as a NOP but will still prefetch [PC]. The loop will then execute again. This will continue as long as the loop end address [PC – 2] is prefetched and the loop does not terminate. If the value in the DCOUNT register reaches zero and on a subsequent decrement generates a borrow, the loop will terminate. However, in such a case the initial instruction outside the loop is once again the first loop instruction.</p> <p>For example:</p> <pre>           DO #33, end_loop ;DO is a two-word instruction end_loop: NOP                ;2nd word of DO executes as a NOP           ADD W2,W3,W4       ;First instruction in DO loop([PC]) </pre>
0	<p>Execution starts at the first instruction in the loop (i.e., at [PC]) and continues until the loop end address ([PC]) is prefetched. If the loop continues, this prefetch causes the DO loop hardware to load the DOEND address ([PC]) into the PC for the next fetch (which will be [PC] again). After the first true iteration of the loop, the first instruction in the loop executes repeatedly until the loop count underflows and the loop terminates. When this occurs, the initial instruction outside the loop is the instruction after [PC].</p> <p>For example:</p> <pre>           DO #33, end_loop ;DO is a two-word instruction           NOP                ;2nd word of DO executes as a NOP end_loop: ADD W2,W3,W4       ;First instruction in DO loop([PC]) </pre>

## 2.10 ADDRESS REGISTER DEPENDENCIES

The dsPIC33F/PIC24H architecture supports a data space read (source) and a data space write (destination) for most MCU class instructions. The Effective Address (EA) calculation by the AGU, and subsequent data space read or write, each take one instruction cycle to complete. This timing causes the data space read and write operations for each instruction to partially overlap, as shown in Figure 2-21. Because of this overlap, a Read-After-Write (RAW) data dependency can occur across instruction boundaries. RAW data dependencies are detected and handled at run-time by the dsPIC33F/PIC24H CPU.

**Figure 2-21: Data Space Access Timing**

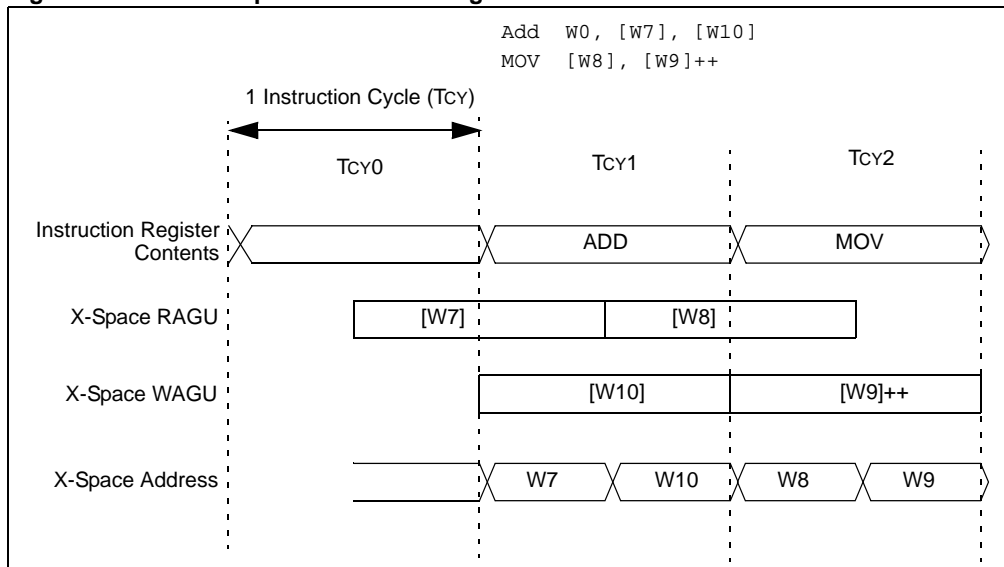

### 2.10.1 Read-After-Write (RAW) Dependency Rules

If the W register is used as a write operation destination in the current instruction, and the W register being read in the prefetched instruction are the same, the following rules apply:

- If the destination write (current instruction) does not modify the contents of  $W_n$ , no stalls will occur
- If the source read (prefetched instruction) does not calculate an EA using  $W_n$ , no stalls will occur

During each instruction cycle, the dsPIC33F/PIC24H hardware automatically checks to see if a RAW data dependency is about to occur. If the conditions specified above are not satisfied, the CPU automatically adds a one-instruction-cycle delay before executing the prefetched instruction. The instruction stall provides enough time for the destination W register write to take place before the next (prefetched) instruction uses the written data. Table 2-9 provides the RAW dependency summary.

**Table 2-9: Read-After-Write Dependency Summary**

Destination Addressing Mode Using Wn	Source Addressing Mode Using Wn	Status	Examples (Wn = W2)
Direct	Direct	Allowed	ADD.w W0, W1, W2 MOV.w W2, W3
Direct	Indirect	Stall	ADD.w W0, W1, W2 MOV.w [W2], W3
Direct	Indirect with modification	Stall	ADD.w W0, W1, W2 MOV.w [W2++], W3
Indirect	Direct	Allowed	ADD.w W0, W1, [W2] MOV.w W2, W3
Indirect	Indirect	Allowed	ADD.w W0, W1, [W2] MOV.w [W2], W3
Indirect	Indirect with modification	Allowed	ADD.w W0, W1, [W2] MOV.w [W2++], W3
Indirect with modification	Direct	Allowed	ADD.w W0, W1, [W2++] MOV.w W2, W3
Indirect	Indirect	Stall	ADD.w W0, W1, [W2] MOV.w [W2], W3 ; W2=0x0004 (mapped W2)
Indirect	Indirect with modification	Stall	ADD.w W0, W1, [W2] MOV.w [W2++], W3 ; W2=0x0004 (mapped W2)
Indirect with modification	Indirect	Stall	ADD.w W0, W1, [W2++] MOV.w [W2], W3
Indirect with modification	Indirect with modification	Stall	ADD.w W0, W1, [W2++] MOV.w [W2++], W3

## 2.10.2 Instruction Stall Cycles

An instruction stall is essentially a one instruction cycle wait period appended in front of the read phase of an instruction to allow the prior write to complete before the next read operation. For the purposes of interrupt latency, the stall cycle is associated with the instruction following the instruction where it was detected (i.e., stall cycles always precede instruction execution cycles).

If a RAW data dependency is detected, the dsPIC33F/PIC24H CPU begins an instruction stall. During an instruction stall, the following events occur:

- The write operation underway (for the previous instruction) is allowed to complete as normal.
- Data space is not addressed until after the instruction stall.
- PC increment is inhibited until after the instruction stall.
- Further instruction fetches are inhibited until after the instruction stall.

### 2.10.2.1 INSTRUCTION STALL CYCLES AND INTERRUPTS

When an interrupt event coincides with two adjacent instructions that will cause an instruction stall, one of two possible outcomes can occur:

- If the interrupt coincides with the first instruction, the first instruction is allowed to complete while the second instruction is executed after the ISR completes. In this case, the stall cycle is eliminated from the second instruction because the exception process provides time for the first instruction to complete the write phase.
- If the interrupt coincides with the second instruction, the second instruction and the appended stall cycle are allowed to execute before to the ISR. In this case, the stall cycle associated with the second instruction executes normally. However, the stall cycle is effectively absorbed into the exception process timing. The exception process proceeds as if an ordinary one-cycle instruction or two-cycle instruction is interrupted.

### 2.10.2.2 INSTRUCTION STALL CYCLES AND FLOW CHANGE INSTRUCTIONS

The `CALL` and `RCALL` instructions write to the stack using working register `W15` and can, therefore, force an instruction stall prior to the next instruction, if the source read of the next instruction uses `W15`.

The `RETFIE` and `RETURN` instructions can never force an instruction stall prior to the next instruction because they only perform read operations. However, the `RETLW` instruction can force a stall, because it writes to a `W` register during the last cycle.

The `GOTO` and branch instructions can never force an instruction stall because they do not perform write operations.

### 2.10.2.3 INSTRUCTION STALLS AND `DO` AND `REPEAT` LOOPS

Other than the addition of instruction stall cycles, RAW data dependencies do not affect the operation of either `DO` or `REPEAT` loops.

The prefetched instruction within a `REPEAT` loop does not change until the loop is complete or an exception occurs. Although register dependency checks occur across instruction boundaries, the dsPIC33F/PIC24H CPU effectively compares the source and destination of the same instruction during a `REPEAT` loop.

The last instruction of a `DO` loop will either prefetch the instruction at the loop start address or the next instruction (outside the loop). The instruction stall decision is based on the last instruction in the loop and the contents of the prefetched instruction.

### 2.10.2.4 INSTRUCTION STALLS AND PROGRAM SPACE VISIBILITY (PSV)

When Program Space (PS) is mapped to data space by enabling the PSV bit (`CORCON<2>`), and the X space EA falls within the visible program space window, the read cycle redirects to the address in program space. Accessing data from program space takes up to three instruction cycles.

Instructions operating in PSV address space are subject to RAW data dependencies and consequent instruction stalls, just like any other instruction. Consider the code segment, as shown in [Example 2-10](#).

#### Example 2-10: Code Example to Operate on the PSV

```
ADD    W0, [W1], [W2++]      ; PSV = 1, W1=0x8000, PSVPAG=0xAA
MOV    [W2], [W3]
```

This sequence of instructions would take five instruction cycles to execute. Two instruction cycles are added to perform the PSV access via `W1`. An instruction stall cycle is inserted to resolve the RAW data dependency caused by `W2`.

## 2.11 REGISTER MAPS

A summary of the registers associated with the dsPIC33F/PIC24H CPU is provided in [Table 2-3](#).

**Table 2-10: CPU Register Map**

Name	Bit 15	Bit 14	Bit 13	Bit 12	Bit 11	Bit 10	Bit 9	Bit 8	Bit 7	Bit 6	Bit 5	Bit 4	Bit 3	Bit 2	Bit 1	Bit 0	All Resets	
W0	W0 (WREG)																0000 0000 0000 0000	
W1	W1																0000 0000 0000 0000	
W2	W2																0000 0000 0000 0000	
W3	W3																0000 0000 0000 0000	
W4	W4																0000 0000 0000 0000	
W5	W5																0000 0000 0000 0000	
W6	W6																0000 0000 0000 0000	
W7	W7																0000 0000 0000 0000	
W8	W8																0000 0000 0000 0000	
W9	W9																0000 0000 0000 0000	
W10	W10																0000 0000 0000 0000	
W11	W11																0000 0000 0000 0000	
W12	W12																0000 0000 0000 0000	
W13	W13																0000 0000 0000 0000	
W14	W14																0000 0000 0000 0000	
W15	W15																0000 0000 0000 0000	
SPLIM	SPLIM																0000 0000 0000 0000	
ACCAL	ACCAL																0000 0000 0000 0000	
ACCAH	ACCAH																0000 0000 0000 0000	
ACCAU	Sign-extension of ACCA<39>								ACCAU								0000 0000 0000 0000	
ACCBL	ACCBL																0000 0000 0000 0000	
ACCBH	ACCBH																0000 0000 0000 0000	
ACCBU	Sign-extension of ACCB<39>								ACCBU								0000 0000 0000 0000	
PCL	PCL																0000 0000 0000 0000	
PCH	—	—	—	—	—	—	—	—	—	PCH						0	0000 0000 0000 0000	
TBLPAG	—	—	—	—	—	—	—	—	TBLPAG								0000 0000 0000 0000	
PSVPAG	—	—	—	—	—	—	—	—	PSVPAG								0000 0000 0000 0000	
RCOUNT	RCOUNT																xxxx xxxx xxxx xxxx	
DCOUNT	DCOUNT																xxxx xxxx xxxx xxxx	
DOSTARTL	DOSTARTL																0	xxxx xxxx xxxx xxx0
DOSTARTH	—	—	—	—	—	—	—	—	—	DOSTARTH						0000 0000 00xx xxxxx		

**Legend:** x = unknown value on Reset, — = unimplemented, read as '0'. Reset values are shown in hexadecimal.

**Note:** Refer to the device data sheet for more details on the specific core register map.



**Table 2-10: CPU Register Map (Continued)**

Name	Bit 15	Bit 14	Bit 13	Bit 12	Bit 11	Bit 10	Bit 9	Bit 8	Bit 7	Bit 6	Bit 5	Bit 4	Bit 3	Bit 2	Bit 1	Bit 0	All Resets
DOENDL	DOENDL															0	xxxx xxxx xxxx xxx0
DOENDH	—	—	—	—	—	—	—	—	—	—	DOENDH						0000 0000 00xx xxxx
SR	OA	OB	SA	SB	OAB	SAB	DA	DC	IPL2	IPL1	IPL0	RA	N	OV	Z	C	0000 0000 0000 0000
CORCON	—	—	—	US	EDT	DL<2:0>			SATA	SATB	SATDW	ACCSAT	IPL3	PSV	RND	IF	0000 0000 0010 0000
MODCON	XMODEN	YMODEN	—	—	BWM<3:0>				YWM<3:0>				XWM<3:0>				0000 0000 0000 0000
XMODSRT	XMODSRT<15:0>															0	xxxx xxxx xxxx xxx0
XMODEND	XMODEND<15:0>															1	xxxx xxxx xxxx xxx1
YMODSRT	YMODSRT<15:0>															0	xxxx xxxx xxxx xxx0
YMODEND	YMODEND<15:0>															1	xxxx xxxx xxxx xxx1
XBREV	BREN	XBREV<14:0>															xxxx xxxx xxxx xxxx
DISICNT	—	—	DISICNT<13:0>													0000 0000 0000 0000	

**Legend:** x = unknown value on Reset, — = unimplemented, read as '0'. Reset values are shown in hexadecimal.

**Note:** Refer to the device data sheet for more details on the specific core register map.

## 2.12 RELATED APPLICATION NOTES

This section lists application notes that are related to this section of the manual. These application notes may not be written specifically for the dsPIC33F/PIC24H Product Family, but the concepts are pertinent and could be used with modification and possible limitations. The current application notes related to the CPU module include the following:

Title	Application Note #
No related application notes at this time.	N/A

<b>Note:</b> Please visit the Microchip web site ( <a href="http://www.microchip.com">www.microchip.com</a> ) for additional Application Notes and code examples for the dsPIC33F/PIC24H family of devices.
---

## 2.13 REVISION HISTORY

### Revision A (April 2007)

This is the initial released version of this document.

### Revision B (September 2009)

This revision incorporates the following updates:

- Note:
  - Added a note on program memory error in [2.8.7 “Address Register Dependencies”](#)
- Registers:
  - Removed the Address column in [Table 2-10](#) in [2.11 “Register Maps”](#)
- Sections:
  - Updated [2.1 “Introduction”](#) with the following data: All instructions execute in a single cycle, except the instructions that change the program flow, double-word move (MOV.D) instruction, table instructions and also the instructions accessing Program Space Visibility (PSV) take more than one cycle
  - Updated the REPEAT count value as “DO iteration count value” in [2.9.2 “DO Loop Construct”](#)
  - Updated the exception process in [2.10.2.1 “Instruction Stall Cycles and Interrupts”](#) as follows: The exception process proceeds as if an ordinary one-cycle instruction or two-cycle instruction is interrupted
  - Updated the read or write cycle as “read cycle” in [2.10.2.4 “Instruction Stalls and Program Space Visibility \(PSV\)”](#)
- Tables:
  - Added a table (see [Table 2-5](#)) on Multiplication Options in [2.6.2.2 “MCU Multiply Instructions”](#)
- Updated the incorrect references to external documents specified in this document.
- Additional minor corrections such as language and formatting updates were incorporated throughout the document

### Revision C (September 2011)

This revision includes the following updates:

- All occurrences of dsPIC33F were changed to dsPIC33F/PIC24H
- The Preliminary document status was removed
- The STATUS register bit, shown as ‘SZ’, was corrected to ‘Z’ in the Programmer’s Model (see [Figure 2-2](#))
- Updated Accessing W Register in File Register Instruction (see [Example 2-3](#))
- Added a sentence with a cross-reference to the CORCON register in [2.4.2 “Core Control Register: CORCON”](#)
- Minor corrections to text and formatting were incorporated throughout the document

NOTES:

---

---

**Note the following details of the code protection feature on Microchip devices:**

- Microchip products meet the specification contained in their particular Microchip Data Sheet.
- Microchip believes that its family of products is one of the most secure families of its kind on the market today, when used in the intended manner and under normal conditions.
- There are dishonest and possibly illegal methods used to breach the code protection feature. All of these methods, to our knowledge, require using the Microchip products in a manner outside the operating specifications contained in Microchip's Data Sheets. Most likely, the person doing so is engaged in theft of intellectual property.
- Microchip is willing to work with the customer who is concerned about the integrity of their code.
- Neither Microchip nor any other semiconductor manufacturer can guarantee the security of their code. Code protection does not mean that we are guaranteeing the product as "unbreakable."

Code protection is constantly evolving. We at Microchip are committed to continuously improving the code protection features of our products. Attempts to break Microchip's code protection feature may be a violation of the Digital Millennium Copyright Act. If such acts allow unauthorized access to your software or other copyrighted work, you may have a right to sue for relief under that Act.

---

Information contained in this publication regarding device applications and the like is provided only for your convenience and may be superseded by updates. It is your responsibility to ensure that your application meets with your specifications. MICROCHIP MAKES NO REPRESENTATIONS OR WARRANTIES OF ANY KIND WHETHER EXPRESS OR IMPLIED, WRITTEN OR ORAL, STATUTORY OR OTHERWISE, RELATED TO THE INFORMATION, INCLUDING BUT NOT LIMITED TO ITS CONDITION, QUALITY, PERFORMANCE, MERCHANTABILITY OR FITNESS FOR PURPOSE. Microchip disclaims all liability arising from this information and its use. Use of Microchip devices in life support and/or safety applications is entirely at the buyer's risk, and the buyer agrees to defend, indemnify and hold harmless Microchip from any and all damages, claims, suits, or expenses resulting from such use. No licenses are conveyed, implicitly or otherwise, under any Microchip intellectual property rights.

**Trademarks**

The Microchip name and logo, the Microchip logo, dsPIC, KEELOQ, KEELOQ logo, MPLAB, PIC, PICmicro, PICSTART, PIC<sup>32</sup> logo, rPIC and UNI/O are registered trademarks of Microchip Technology Incorporated in the U.S.A. and other countries.

FilterLab, Hampshire, HI-TECH C, Linear Active Thermistor, MXDEV, MXLAB, SEEVAL and The Embedded Control Solutions Company are registered trademarks of Microchip Technology Incorporated in the U.S.A.

Analog-for-the-Digital Age, Application Maestro, chipKIT, chipKIT logo, CodeGuard, dsPICDEM, dsPICDEM.net, dsPICworks, dsSPEAK, ECAN, ECONOMONITOR, FanSense, HI-TIDE, In-Circuit Serial Programming, ICSP, Mindi, MiWi, MPASM, MPLAB Certified logo, MPLIB, MPLINK, mTouch, Omniscent Code Generation, PICC, PICC-18, PICDEM, PICDEM.net, PICkit, PICtail, REAL ICE, rfLAB, Select Mode, Total Endurance, TSHARC, UniWinDriver, WiperLock and ZENA are trademarks of Microchip Technology Incorporated in the U.S.A. and other countries.

SQTP is a service mark of Microchip Technology Incorporated in the U.S.A.

All other trademarks mentioned herein are property of their respective companies.

© 2007-2011, Microchip Technology Incorporated, Printed in the U.S.A., All Rights Reserved.

 Printed on recycled paper.

ISBN: 978-1-61341-659-4

*Microchip received ISO/TS-16949:2009 certification for its worldwide headquarters, design and wafer fabrication facilities in Chandler and Tempe, Arizona; Gresham, Oregon and design centers in California and India. The Company's quality system processes and procedures are for its PIC<sup>®</sup> MCUs and dsPIC<sup>®</sup> DSCs, KEELOQ<sup>®</sup> code hopping devices, Serial EEPROMs, microperipherals, nonvolatile memory and analog products. In addition, Microchip's quality system for the design and manufacture of development systems is ISO 9001:2000 certified.*

**QUALITY MANAGEMENT SYSTEM**  
**CERTIFIED BY DNV**  
**== ISO/TS 16949:2009 ==**



# MICROCHIP

## Worldwide Sales and Service

### AMERICAS

**Corporate Office**  
2355 West Chandler Blvd.  
Chandler, AZ 85224-6199  
Tel: 480-792-7200  
Fax: 480-792-7277  
Technical Support:  
<http://www.microchip.com/support>  
Web Address:  
[www.microchip.com](http://www.microchip.com)

**Atlanta**  
Duluth, GA  
Tel: 678-957-9614  
Fax: 678-957-1455

**Boston**  
Westborough, MA  
Tel: 774-760-0087  
Fax: 774-760-0088

**Chicago**  
Itasca, IL  
Tel: 630-285-0071  
Fax: 630-285-0075

**Cleveland**  
Independence, OH  
Tel: 216-447-0464  
Fax: 216-447-0643

**Dallas**  
Addison, TX  
Tel: 972-818-7423  
Fax: 972-818-2924

**Detroit**  
Farmington Hills, MI  
Tel: 248-538-2250  
Fax: 248-538-2260

**Indianapolis**  
Noblesville, IN  
Tel: 317-773-8323  
Fax: 317-773-5453

**Los Angeles**  
Mission Viejo, CA  
Tel: 949-462-9523  
Fax: 949-462-9608

**Santa Clara**  
Santa Clara, CA  
Tel: 408-961-6444  
Fax: 408-961-6445

**Toronto**  
Mississauga, Ontario,  
Canada  
Tel: 905-673-0699  
Fax: 905-673-6509

### ASIA/PACIFIC

**Asia Pacific Office**  
Suites 3707-14, 37th Floor  
Tower 6, The Gateway  
Harbour City, Kowloon  
Hong Kong  
Tel: 852-2401-1200  
Fax: 852-2401-3431

**Australia - Sydney**  
Tel: 61-2-9868-6733  
Fax: 61-2-9868-6755

**China - Beijing**  
Tel: 86-10-8569-7000  
Fax: 86-10-8528-2104

**China - Chengdu**  
Tel: 86-28-8665-5511  
Fax: 86-28-8665-7889

**China - Chongqing**  
Tel: 86-23-8980-9588  
Fax: 86-23-8980-9500

**China - Hangzhou**  
Tel: 86-571-2819-3187  
Fax: 86-571-2819-3189

**China - Hong Kong SAR**  
Tel: 852-2401-1200  
Fax: 852-2401-3431

**China - Nanjing**  
Tel: 86-25-8473-2460  
Fax: 86-25-8473-2470

**China - Qingdao**  
Tel: 86-532-8502-7355  
Fax: 86-532-8502-7205

**China - Shanghai**  
Tel: 86-21-5407-5533  
Fax: 86-21-5407-5066

**China - Shenyang**  
Tel: 86-24-2334-2829  
Fax: 86-24-2334-2393

**China - Shenzhen**  
Tel: 86-755-8203-2660  
Fax: 86-755-8203-1760

**China - Wuhan**  
Tel: 86-27-5980-5300  
Fax: 86-27-5980-5118

**China - Xian**  
Tel: 86-29-8833-7252  
Fax: 86-29-8833-7256

**China - Xiamen**  
Tel: 86-592-2388138  
Fax: 86-592-2388130

**China - Zhuhai**  
Tel: 86-756-3210040  
Fax: 86-756-3210049

### ASIA/PACIFIC

**India - Bangalore**  
Tel: 91-80-3090-4444  
Fax: 91-80-3090-4123

**India - New Delhi**  
Tel: 91-11-4160-8631  
Fax: 91-11-4160-8632

**India - Pune**  
Tel: 91-20-2566-1512  
Fax: 91-20-2566-1513

**Japan - Yokohama**  
Tel: 81-45-471- 6166  
Fax: 81-45-471-6122

**Korea - Daegu**  
Tel: 82-53-744-4301  
Fax: 82-53-744-4302

**Korea - Seoul**  
Tel: 82-2-554-7200  
Fax: 82-2-558-5932 or  
82-2-558-5934

**Malaysia - Kuala Lumpur**  
Tel: 60-3-6201-9857  
Fax: 60-3-6201-9859

**Malaysia - Penang**  
Tel: 60-4-227-8870  
Fax: 60-4-227-4068

**Philippines - Manila**  
Tel: 63-2-634-9065  
Fax: 63-2-634-9069

**Singapore**  
Tel: 65-6334-8870  
Fax: 65-6334-8850

**Taiwan - Hsin Chu**  
Tel: 886-3-5778-366  
Fax: 886-3-5770-955

**Taiwan - Kaohsiung**  
Tel: 886-7-536-4818  
Fax: 886-7-330-9305

**Taiwan - Taipei**  
Tel: 886-2-2500-6610  
Fax: 886-2-2508-0102

**Thailand - Bangkok**  
Tel: 66-2-694-1351  
Fax: 66-2-694-1350

### EUROPE

**Austria - Wels**  
Tel: 43-7242-2244-39  
Fax: 43-7242-2244-393

**Denmark - Copenhagen**  
Tel: 45-4450-2828  
Fax: 45-4485-2829

**France - Paris**  
Tel: 33-1-69-53-63-20  
Fax: 33-1-69-30-90-79

**Germany - Munich**  
Tel: 49-89-627-144-0  
Fax: 49-89-627-144-44

**Italy - Milan**  
Tel: 39-0331-742611  
Fax: 39-0331-466781

**Netherlands - Druenen**  
Tel: 31-416-690399  
Fax: 31-416-690340

**Spain - Madrid**  
Tel: 34-91-708-08-90  
Fax: 34-91-708-08-91

**UK - Wokingham**  
Tel: 44-118-921-5869  
Fax: 44-118-921-5820

08/02/11