



Section 2. CPU

HIGHLIGHTS

This section of the manual contains the following topics:

2.1	Introduction	2-2
2.2	Programmer's Model.....	2-5
2.3	Software Stack Pointer.....	2-9
2.4	CPU Register Descriptions	2-13
2.5	Arithmetic Logic Unit (ALU).....	2-19
2.6	DSP Engine	2-20
2.7	Divide Support	2-30
2.8	Instruction Flow Types	2-31
2.9	Loop Constructs.....	2-34
2.10	Address Register Dependencies	2-39
2.11	Data Space Arbiter Stalls	2-41
2.12	Register Map.....	2-42
2.13	Related Application Notes.....	2-44
2.14	Revision History.....	2-45
	Worldwide Sales and Service	2-48

2.1 INTRODUCTION

Note: This family reference manual section is meant to serve as a complement to device data sheets. Depending on the device variant, this manual section may not apply to all dsPIC33E/PIC24E devices.

Please consult the note at the beginning of the “**CPU**” chapter in the current device data sheet to check whether this document supports the device you are using.

Device data sheets and family reference manual sections are available for download from the Microchip Worldwide Web site at: <http://www.microchip.com>

The dsPIC33E/PIC24E CPU has a 16-bit (data) modified Harvard architecture with an enhanced instruction set, including significant support for digital signal processing. The CPU has a 24-bit instruction word, with a variable length opcode field. The Program Counter (PC) is 24 bits wide and addresses up to 4M x 24 bits of user program memory space.

An instruction prefetch mechanism helps maintain throughput and provides predictable execution. Most instructions execute in a single-cycle effective execution rate, with the exception of instructions that change the program flow, like the double-word Move (MOV.D) instruction, PSV accesses and the table instructions. Overhead free program loop constructs are supported using the DO and REPEAT instructions, both of which are interruptible at any point.

2.1.1 Registers

The dsPIC33E/PIC24E devices have sixteen 16-bit working registers in the programmer's model. Each of the working registers can act as a data, address or address offset register. The 16th working register (W15) operates as a software stack pointer for interrupts and calls.

2.1.2 Instruction Set

The dsPIC33E/PIC24E instruction set has two classes of instructions:

- MCU class of instructions
- DSP class of instructions

These two instruction classes are seamlessly integrated into the architecture and execute from a single execution unit. The instruction set includes many Addressing modes and was designed for optimum C compiler efficiency.

2.1.3 Data Space Addressing

The base data space can be addressed as 32K words or 64 Kbytes and is split into two blocks, as X and Y data memory. Each memory block has its own independent Address Generation Unit (AGU). The MCU class of instructions operate solely through the X memory AGU, which accesses the entire memory map as one linear data space. Certain DSP instructions operate through the X and Y AGUs to support dual operand reads, which splits the data address space into two parts. The X and Y data space boundary is device specific.

The upper 32 Kbytes of the data space memory map can optionally be mapped into program space at any 16K program word boundary. The program-to-data-space mapping feature known as Program Space Visibility (PSV), allows any instruction access program space as if it were data space. Moreover, the Base Data Space address is used in conjunction with a read or write page register (DSRPAG or DSWPAG) to form an Extended Data Space (EDS) address. The EDS can be addressed as 8M words or 16 Mbytes. Refer to **Section 3. “Data Memory”** (DS70595) for more details on EDS, PSV and table accesses.

In dsPIC33E devices, overhead-free circular buffers (modulo addressing) are supported in both X and Y address spaces. The modulo addressing removes the software boundary-checking overhead for DSP algorithms. The X AGU circular addressing can be used with any of the MCU class of instructions. The X AGU also supports bit-reverse addressing to greatly simplify input or output data reordering for radix-2 FFT algorithms.

2.1.4 Addressing Modes

The CPU supports the following addressing modes:

- Inherent (no operand)
- Relative
- Literal
- Memory Direct
- Register Direct
- Register Indirect

Each instruction is associated with a predefined Addressing mode group, depending upon its functional requirements. As many as six Addressing modes are supported for each instruction.

For most instructions, the dsPIC33E/PIC24E can execute the following functions in a single instruction cycle:

- Data memory read
- Working register (data) read
- Data memory write
- Program (instruction) memory read

As a result, three operand instructions can be supported, allowing $A+B=C$ operations to be executed in a single cycle.

2.1.5 DSP Engine and Instructions (dsPIC33E Devices Only)

The DSP engine features:

- A high speed 17-bit by 17-bit multiplier
- A 40-bit ALU
- Two 40-bit saturating accumulators
- A 40-bit bidirectional barrel shifter, capable of shifting a 40-bit value up to 16 bits right, or up to 16 bits left, in a single cycle

The DSP instructions operate seamlessly with all other instructions and are designed for optimal real-time performance. The `MAC` instruction and other associated instructions can concurrently fetch two data operands from memory while multiplying two `W` registers. This requires that the data space be split for these instructions and linear for all others. This is achieved in a transparent and flexible manner by assigning certain working registers to each address space.

2.1.6 Exception Processing

The dsPIC33E/PIC24E has a vectored exception scheme with up to eight possible sources of non-maskable traps and up to 246 possible interrupt sources. Each interrupt source can be assigned to one of seven priority levels. The user can select between fixed and variable interrupt latency depending on the application requirements. For more information on interrupt latency, refer to **Section 6. “Interrupts”** (DS70600). Figure 2-1 illustrates dsPIC33E/PIC24E CPU block diagram.

dsPIC33E/PIC24E Family Reference Manual

Figure 2-1: dsPIC33E/PIC24E CPU Block Diagram

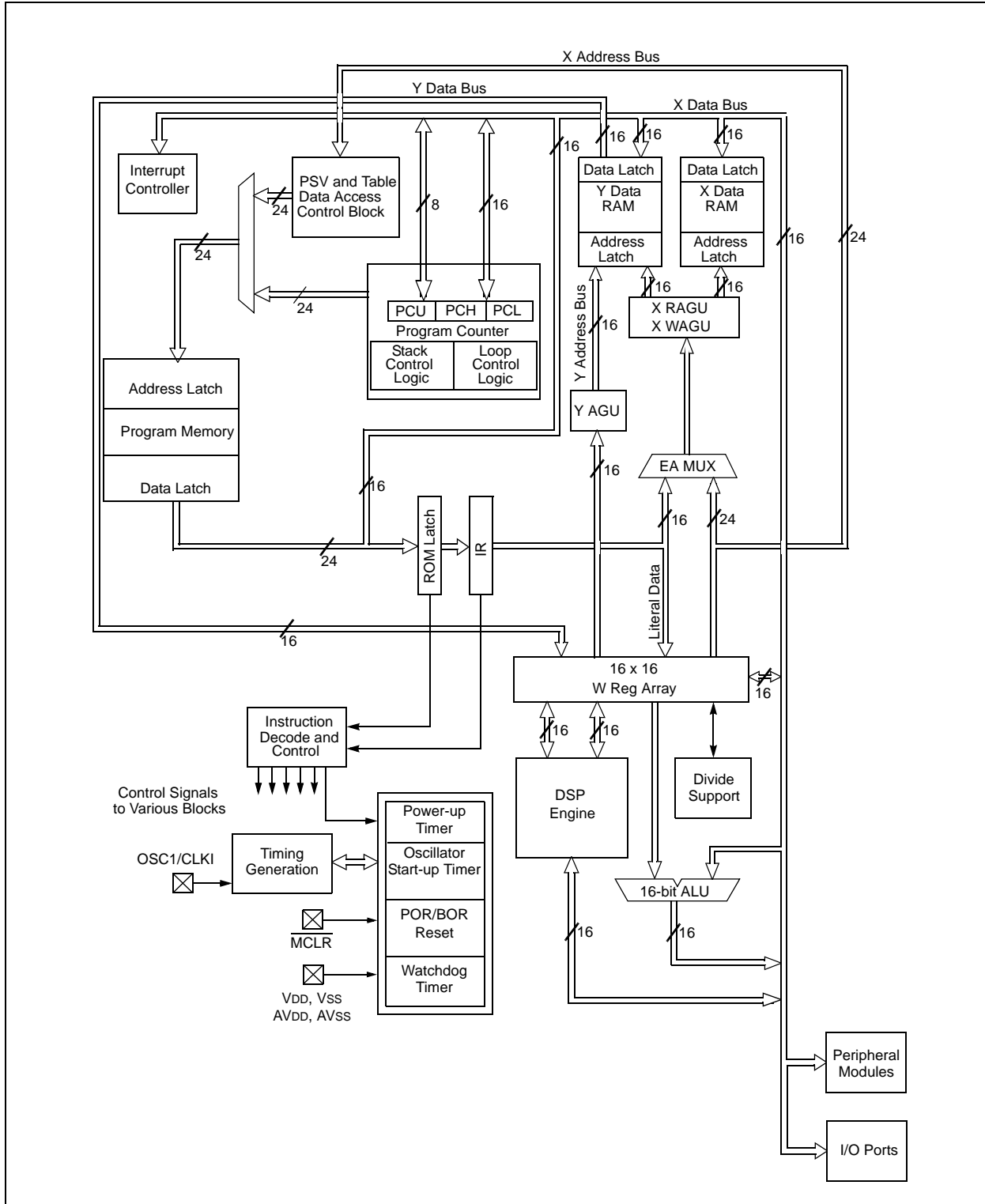

2.2 PROGRAMMER'S MODEL

The programmer's model for the dsPIC33E/PIC24E is shown in Figure 2-2. All registers in the programmer's model are memory mapped and can be manipulated directly by instructions. Table 2-1 provides a description of each register in the programmer's model.

Table 2-1: Programmer's Model Register Descriptions

Register(s) Name	Description
W0 through W15	Working register array
ACCA, ACCB ⁽¹⁾	40-bit DSP Accumulators
PC	23-bit Program Counter
SR	ALU and DSP Engine Status register
SPLIM	Stack Pointer Limit Value register
TBLPAG	Table Memory Page Address register
DSRPAG	Extended Data Space (EDS) Read Page register
DSWPAG	Extended Data Space (EDS) Write Page register
RCOUNT	REPEAT Loop Count register
DCOUNT ⁽¹⁾	DO Loop Count register
DOSTARTH, DOSTARTL ⁽¹⁾	DO Loop Start Address register (High and Low)
DOENDH, DOENDL ⁽¹⁾	DO Loop End Address register (High and Low)
CORCON	Contains DSP Engine and DO Loop control bits

Note 1: These registers are only present in dsPIC33E devices. Please refer to the specific device data sheet for availability.

In addition to the registers contained in the programmer's model, the dsPIC33E/PIC24E contains control registers for modulo addressing, bit-reversed addressing and interrupts. These registers are described in subsequent sections of this document.

All registers associated with the programmer's model are memory mapped, as shown in Table 2-8.

dsPIC33E/PIC24E Family Reference Manual

Figure 2-2: Programmer's Model

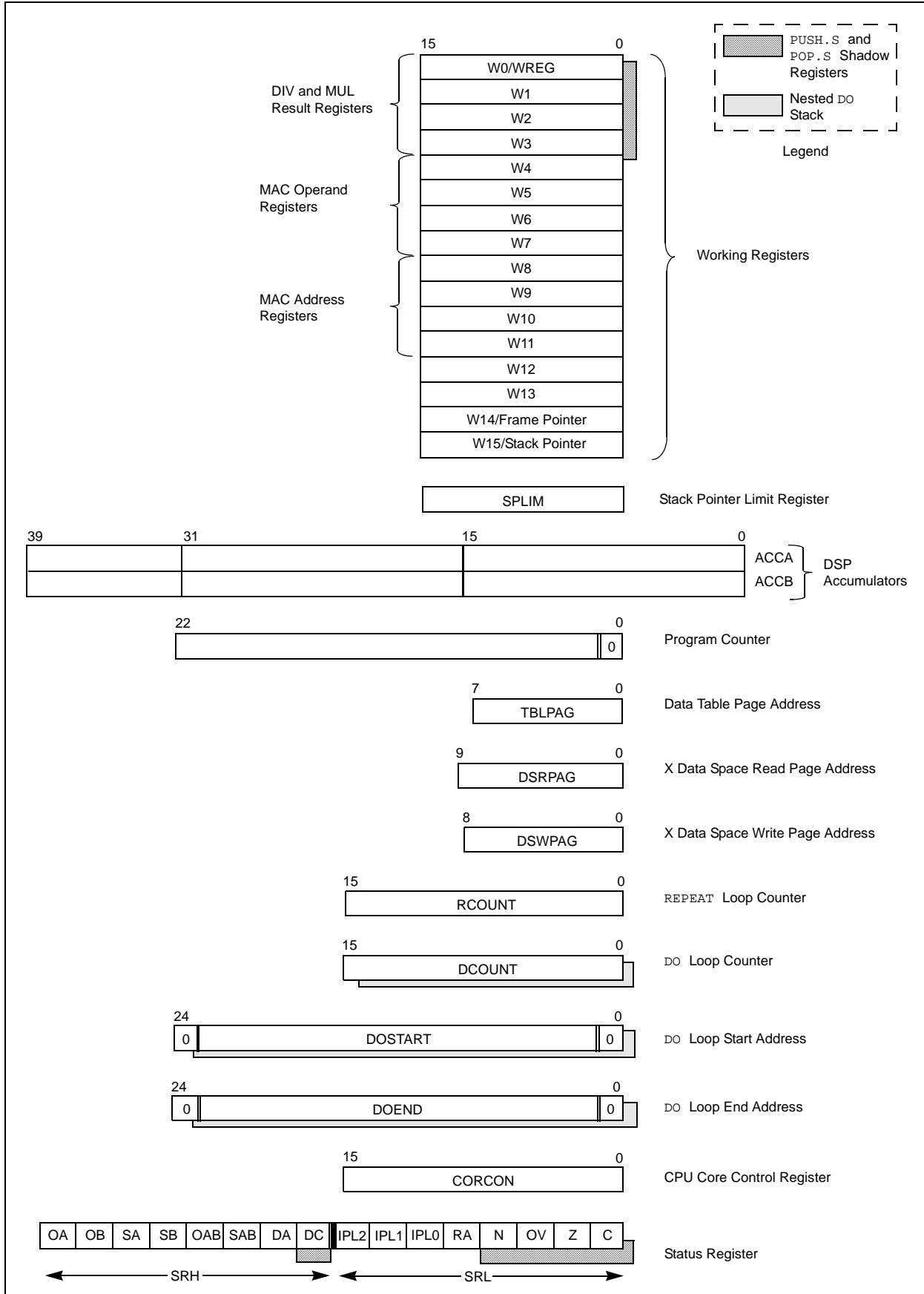

2.2.1 Working Register Array

The 16 Working (W) registers can function as data, address or address offset registers. The function of a W register is determined by the Addressing mode of the instruction that accesses it.

The dsPIC33E/PIC24E instruction set can be divided into two instruction types:

- Register instructions
- File register instructions

2.2.1.1 REGISTER INSTRUCTIONS

Register instructions can use each W register as a data value or an address offset value. Example 2-1 shows Register instructions.

Example 2-1:

```
MOV W0,W1      ; move contents of W0 to W1
MOV W0,[W1]    ; move W0 to address contained in W1
ADD W0,[W4],W5 ; add contents of W0 to contents pointed
                ; to by W4. Place result in W5.
```

2.2.1.2 FILE REGISTER INSTRUCTIONS

File register instructions operate on a specific memory address contained in the instruction opcode and register W0. W0 is a special working register used in file register instructions. Working registers W1-W15 cannot be specified as target registers in file register instructions.

The file register instructions provide backward compatibility with existing PIC® MCU devices, which have only one W register. The label 'WREG' is used in the assembler syntax to denote W0 in a file register instruction. Example 2-2 shows File register instructions.

Example 2-2:

```
MOV WREG,0x0100 ; move contents of W0 to address 0x0100
ADD 0x0100,WREG ; add W0 to address 0x0100, store in W0
```

Note: For a complete description of Addressing modes and instruction syntax, refer to the "16-bit MCU and DSC Programmer's Reference Manual" (DS70157).

2.2.1.3 W REGISTER MEMORY MAPPING

The W registers are memory mapped, and thus it is possible to access a W register in a file register instruction, as shown in the Example 2-3.

Example 2-3:

```
MOV 0x0004, W10 ; equivalent to MOV W2, W10
where:
0x0004 = memory addresses of W2
```

Further, it is also possible to execute an instruction that uses a W register as both an address pointer and operand destination, as shown in Example 2-4.

Example 2-4:

```
MOV W1,[W2++]
where:
W1 = 0x1234
W2 = 0x0004 ;[W2] addresses W2
```

In the example above, the contents of W2 are 0x0004. Since W2 is used as an address pointer, it points to location 0x0004 in memory. W2 is also mapped to this address in memory. Even though this is an unlikely event, it is impossible to detect until run time. The dsPIC33E/PIC24E ensures that the data write dominates, resulting in W2 = 0x1234 in the example above.

2.2.1.4 W REGISTERS AND BYTE MODE INSTRUCTIONS

Byte instructions that target the W register array affect only the Least Significant Byte (LSB) of the target register. Since the working registers are memory mapped, the LSB and the Most Significant Byte (MSB) can be manipulated through byte-wide data memory space accesses.

2.2.2 Shadow Registers

Many of the registers in the programmer's model have an associated shadow register, as shown in Figure 2-2. None of the shadow registers are accessible directly.

The `PUSH.S` and `POP.S` instructions are useful for fast context save/restore during a function call or Interrupt Service Routine (ISR). The `PUSH.S` instruction transfers the following register values into their respective shadow registers:

- W0...W3
- SR (N, OV, Z, C, DC bits only)

The `POP.S` instruction restores the values from the shadow registers into these register locations. Example 2-5 shows code example using the `PUSH.S` and `POP.S` instructions.

Example 2-5:

```
MyFunction:
    PUSH.S           ; Save W registers, MCU status
    MOV    #0x03,W0 ; load a literal value into W0
    ADD   RAM100    ; add W0 to contents of RAM100
    BTSC  SR,#Z     ; is the result 0?
    BSET  Flags,#IsZero ; Yes, set a flag
    POP.S           ; Restore W regs, MCU status
    RETURN
```

The `PUSH.S` instruction overwrites the contents previously saved in the shadow registers. The shadow registers are only one level in depth, so care must be taken if the shadow registers are to be used for multiple software tasks.

The user application must ensure that any task using the shadow registers are not interrupted by a higher-priority task that also uses the shadow registers. If the higher-priority task is allowed to interrupt the lower priority task, the contents of the shadow registers saved in the lower priority task are overwritten by the higher priority task.

2.2.3 Uninitialized W Register Reset

The W register array (with the exception of W15) is cleared during all Resets and is considered uninitialized until written to. An attempt to use an uninitialized register as an address pointer will reset the device.

A word write must be performed to initialize a W register. A byte write will not affect the initialization detection logic.

2.3 SOFTWARE STACK POINTER

The W15 register serves as a dedicated software stack pointer and is automatically modified by exception processing, subroutine calls and returns; however, W15 can be referenced by any instruction in the same manner as all other W registers. This simplifies reading, writing and manipulating of the stack pointer (for example, creating stack frames).

Note: To protect against misaligned stack accesses, W15<0> is fixed to '0' by the hardware.

W15 is initialized to 0x1000 during all Resets. This address ensures that the Stack Pointer (SP) points to valid RAM in all dsPIC33E/PIC24E devices and permits stack availability for non-maskable trap exceptions. These can occur before the SP is initialized by the user software. You can reprogram the SP during initialization to any location within data space.

The stack pointer always points to the first available free word and fills the software stack, working from lower toward higher addresses. Figure 2-3 illustrates how it pre-decrements for a stack pop (read) and post-increments for a stack push (writes).

When the PC is pushed onto the stack, PC<15:0> is pushed onto the first available stack word, then PC<22:16> is pushed into the second available stack location. For a PC push during any CALL instruction, the MSB of the PC is zero-extended before the push, as shown in Figure 2-3. During exception processing, the MSB of the PC is concatenated with the lower 8 bits of the CPU status register, SR. This allows the contents of SRL to be preserved automatically during interrupt processing.

Note: The Stack Pointer, W15, is never subject to paging; therefore, stack addresses are restricted to the Base Data Space (0x0000 – 0xFFFF).

Figure 2-3: Stack Operation for a CALL Instruction

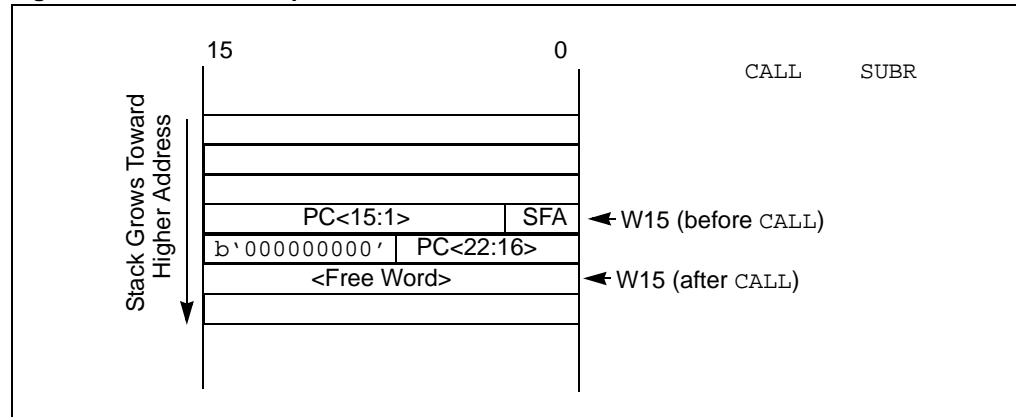

2.3.1 Software Stack Examples

The software stack is manipulated using the PUSH and POP instructions. The PUSH and POP instructions are the equivalent of a MOV instruction with W15 as the destination pointer. For example, the contents of W0 can be pushed onto the stack by:

```
PUSH W0
```

This syntax is equivalent to:

```
MOV W0, [W15++]
```

The contents of the top-of-stack can be returned to W0 by:

```
POP W0
```

This syntax is equivalent to:

```
MOV [--W15], W0
```

Figure 2-4 through Figure 2-7 illustrates examples of how the software stack is used. Figure 2-4 illustrates the software stack at device initialization. W15 has been initialized to 0x1000. This example assumes the values 0x5A5A and 0x3636 have been written to W0 and W1, respectively. In Figure 2-5, the stack is pushed for the first time and the value contained in W0 is copied to the stack. W15 is automatically updated to point to the next available stack location (0x1002). In Figure 2-6, the contents of W1 are pushed onto the stack. Figure 2-7 illustrates how the stack is popped and the top-of-stack value (previously pushed from W1) is written to W3.

Figure 2-4: Stack Pointer at Device Reset

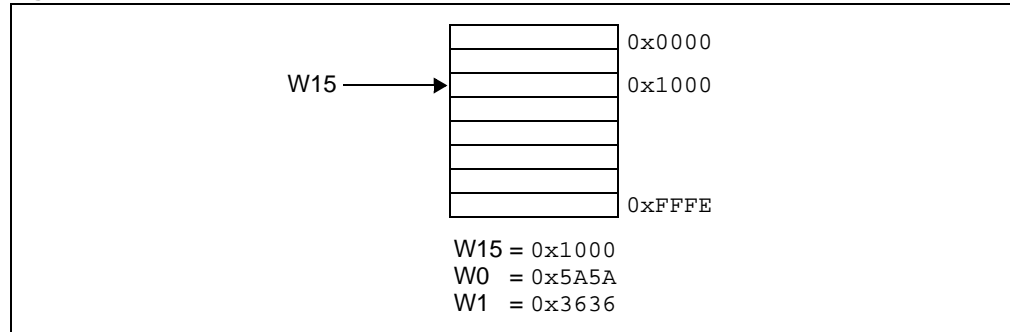

Figure 2-5: Stack Pointer After the First PUSH Instruction

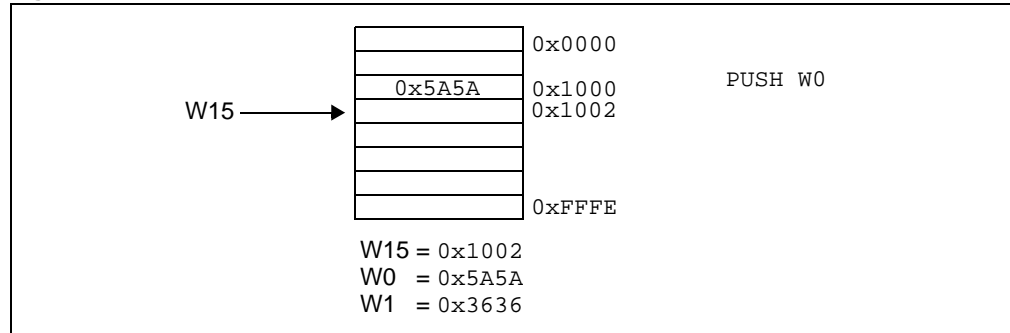

Figure 2-6: Stack Pointer After the Second PUSH Instruction

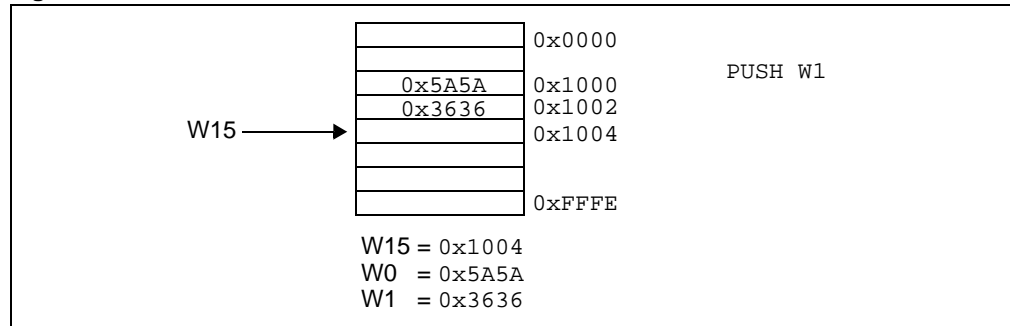

Figure 2-7: Stack Pointer After a POP Instruction



2.3.2 W14 Software Stack Frame Pointer

A frame is a user-defined section of memory in the stack that is used by a single subroutine. working register, W14, which can be used as a stack frame pointer with the `LNK` (link) and `ULNK` (unlink) instructions. W14 can be used in a normal working register by instructions when it is not used as a frame pointer.

For software examples that use W14 as a stack frame pointer, refer to the “16-bit MCU and DSC Programmer’s Reference Manual” (DS70157).

2.3.3 Stack Pointer Overflow

The Stack Pointer Limit register (SPLIM) specifies the size of the stack buffer. SPLIM is a 16-bit register, but SPLIM<0> is fixed to ‘0’ because all stack operations must be word aligned.

The stack overflow check is not enabled until a word write to SPLIM occurs. After this it can only be disabled by a device Reset. All effective addresses generated using W15 as a source or destination are compared against the value in SPLIM. If the contents of the Stack Pointer (W15) exceed the contents of the SPLIM register by 2 and a push operation is performed, a stack error trap occurs on a subsequent push operation. For example, if it is desirable to cause a stack error trap when the stack grows beyond address 0x2000 in RAM, initialize the SPLIM with the value 0x1FFE.

Note: A stack error trap can be caused by any instruction that uses the contents of the W15 register to generate an Effective Address (EA). Therefore, if the contents of W15 are greater than the contents of the SPLIM register by a value of 2, and a `CALL` instruction is executed, or if an interrupt occurs, a stack error trap is generated.

A Stack error trap is also caused by a `LNK` instruction when the SFA bit is high or on a `ULNK` instruction when the SFA bit is ‘0’.

If stack overflow checking is enabled, a stack error trap also occurs if the W15 effective address calculation wraps over the end of data space (0xFFFF).

Note: A write to the SPLIM, should not be followed by an indirect read operation using W15.

For more information on the stack error trap, refer to **Section 6. “Interrupts”** (DS70600).

2.3.4 Stack Pointer Underflow

The stack is initialized to 0x1000 during a Reset. A stack error trap is initiated if the stack pointer address is less than 0x1000.

Note: Locations in data space between 0x0000 and 0x0FFF are, in general, reserved for core and peripheral special function registers.

2.3.5 Stack Frame Active (SFA) Control

W15 is never subject to paging and is therefore restricted to address range 0x000000 to 0x00FFFF. However, the Stack Frame Pointer (W14) for any user software function is only dedicated to that function when a stack frame addressed by W14 is active (i.e., after a `LNK` instruction). Therefore, it is desirable to have the ability to dynamically switch W14 between use as a general purpose W register, and use as a Stack Frame Pointer. The SFA Status (CORCON<2>) bit achieves this function without additional S/W overhead.

When SFA is clear, W14 may be used with any page register. When SFA is set, W14 is not subject to paging and is locked into the same address range as W15 (0x000000 to 0x00FFFF). Operation of the SFA register lock is as follows:

- The `LNK` instruction sets SFA (and creates a stack frame).
- The `ULNK` instruction clears SFA (and deletes the stack frame).

dsPIC33E/PIC24E Family Reference Manual

- The `CALL`, `CALLW`, `CALLWL`, `RCALL` and `RCALLW` instructions or vectored interrupt also stack the SFA bit (placing it in the Least Significant bit (LSb) of the stacked PC), and clear the SFA bit after the stacking operation is complete. The called procedure as well as interrupt vectoring is now free to either use W14 as a general purpose register, or create another stack frame using the `LNK` instruction.
- The `RETURN`, `RETLW` and `RETFIE` instructions all restore the SFA bit from its previously stacked value.

The SFA bit is a read-only bit. It can only be set by execution of the `LNK` instruction, and cleared by the `ULNK`, `CALL`, `CALLW`, `CALLWL`, `RCALL` and `RCALLW` instructions.

2.4 CPU REGISTER DESCRIPTIONS

2.4.1 SR: CPU Status Register

The dsPIC33E/PIC24E CPU has a 16-bit Status Register (SR). A detailed description of the CPU SR is shown in Register 2-1. The LSB of this register is referred to as the SRL (Status Register, Low Byte). The MSB is referred to as SRH (Status Register, High Byte).

SRL contains:

- All MCU ALU operation status flags
- The CPU interrupt priority status bits, IPL<2:0>
- The REPEAT loop active status bit, RA (SR<4>)

During exception processing, SRL is concatenated with the MSB of the PC to form a complete word value, which is then stacked.

SRH contains:

- The DSP Adder/Subtractor status bits
- The DO loop active bit, DA (SR<9>)
- The Digit Carry bit, DC (SR<8>)

The SR bits are readable/writable with the following exceptions:

- The DA bit (SR<8>) is read-only
- The RA bit (SR<4>) is read-only
- The OA, OB (SR<15:14>), OAB (SR<11>), SA, SB (SR<13:12>), and SAB (SR<10>) bits are readable and writable; however, once set, they remain set until cleared by the user application, regardless of the results from any subsequent DSP operations.

Note: Clearing the SAB bit also clears both the SA and SB bits. Similarly, clearing the OAB bit also clears both the OA and OB bits. A description of the Status register bits affected by each instruction is provided in the “16-bit MCU and DSC Programmer’s Reference Manual” (DS70157).

2.4.2 CORCON: Core Control Register

The Core Control Register (CORCON) has bits that control the operation of the DSP multiplier and DO loop hardware. The CORCON register also contains the IPL3 status bit, which is concatenated with IPL<2:0> (SR<7:5>), to form the CPU Interrupt Priority Level.

dsPIC33E/PIC24E Family Reference Manual

Register 2-1: SR: CPU Status Register

R/W-0	R/W-0	R/W-0	R/W-0	R/C-0	R/C-0	R-0	R/W-0
OA ⁽²⁾	OB ⁽²⁾	SA ^(1,2)	SB ^(1,2)	OAB ⁽²⁾	SAB ⁽²⁾	DA ⁽²⁾	DC
bit 15						bit 8	

R/W-0 ^(3,4)	R/W-0 ^(1,2)	R/W-0 ^(3,4)	R-0	R/W-0	R/W-0	R/W-0	R/W-0
IPL<2:0>			RA	N	OV	Z	C
bit 7						bit 0	

Legend:			U = Unimplemented bit, read as '0'				
R = Readable bit	W = Writable bit		C = Clearable bit				
-n = Value at POR	'1' = Bit is set		'0' = Bit is cleared		x = Bit is unknown		

- bit 15 **OA:** Accumulator A Overflow Status bit⁽²⁾
 1 = Accumulator A has overflowed
 0 = Accumulator A has not overflowed
- bit 14 **OB:** Accumulator B Overflow Status bit⁽²⁾
 1 = Accumulator B has overflowed
 0 = Accumulator B has not overflowed
- bit 13 **SA:** Accumulator A Saturation 'Sticky' Status bit^(1,2)
 1 = Accumulator A is saturated or has been saturated at some time
 0 = Accumulator A is not saturated
- bit 12 **SB:** Accumulator B Saturation 'Sticky' Status bit^(1,2)
 1 = Accumulator B is saturated or has been saturated at some time
 0 = Accumulator B is not saturated
- bit 11 **OAB:** OA || OB Combined Accumulator Overflow Status bit⁽²⁾
 1 = Accumulators A or B have overflowed
 0 = Neither Accumulators A or B have overflowed
- bit 10 **SAB:** SA || SB Combined Accumulator 'Sticky' Status bit⁽²⁾
 1 = Accumulators A or B are saturated or have been saturated at some time
 0 = Neither Accumulator A or B are saturated
- bit 9 **DA:** DO Loop Active bit⁽²⁾
 1 = DO loop in progress
 0 = DO loop not in progress
- bit 8 **DC:** MCU ALU Half Carry/Borrow bit
 1 = A carry-out from the 4th low order bit (for byte-sized data) or 8th low order bit (for word-sized data) of the result occurred
 0 = No carry-out from the 4th low order bit (for byte-sized data) or 8th low order bit (for word-sized data) of the result occurred

Note 1: A data write to SR can modify the SA and SB bits by either a data write to SA and SB or by clearing the SAB bit. To avoid a possible SA or SB bit write race condition, the SA and SB bits should not be modified using bit operations.

- 2: These bits are only present in dsPIC33E devices. Please refer to the specific device data sheet for availability.
- 3: The IPL<2:0> bits are concatenated with the IPL<3> bit (CORCON<3>) to form the CPU Interrupt Priority Level. The value in parentheses indicates the IPL, if IPL<3> = 1. User interrupts are disabled when IPL<3> = 1.
- 4: The IPL<2:0> status bits are read only when NSTDIS(INTCON1<15>) = 1.

Register 2-1: SR: CPU Status Register (Continued)

bit 7-5	<p>IPL<2:0>: CPU Interrupt Priority Level Status bits^(3,4)</p> <p>111 = CPU Interrupt Priority Level is 7 (15). User interrupts disabled.</p> <p>110 = CPU Interrupt Priority Level is 6 (14)</p> <p>101 = CPU Interrupt Priority Level is 5 (13)</p> <p>100 = CPU Interrupt Priority Level is 4 (12)</p> <p>011 = CPU Interrupt Priority Level is 3 (11)</p> <p>010 = CPU Interrupt Priority Level is 2 (10)</p> <p>001 = CPU Interrupt Priority Level is 1 (9)</p> <p>000 = CPU Interrupt Priority Level is 0 (8)</p>
bit 4	<p>RA: REPEAT Loop Active bit</p> <p>1 = REPEAT loop in progress</p> <p>0 = REPEAT loop not in progress</p>
bit 3	<p>N: MCU ALU Negative bit</p> <p>1 = Result was negative</p> <p>0 = Result was non-negative (zero or positive)</p>
bit 2	<p>OV: MCU ALU Overflow bit</p> <p>This bit is used for signed arithmetic (2's complement). It indicates an overflow of the magnitude that causes the sign bit to change state.</p> <p>1 = Overflow occurred for signed arithmetic (in this arithmetic operation)</p> <p>0 = No overflow occurred</p>
bit 1	<p>Z: MCU ALU Zero bit</p> <p>1 = An operation that affects the Z bit has set it at some time in the past</p> <p>0 = The most recent operation that affects the Z bit has cleared it (i.e., a non-zero result)</p>
bit 0	<p>C: MCU ALU Carry/Borrow bit</p> <p>1 = A carry-out from the Most Significant bit of the result occurred</p> <p>0 = No carry-out from the Most Significant bit of the result occurred</p>

Note 1: A data write to SR can modify the SA and SB bits by either a data write to SA and SB or by clearing the SAB bit. To avoid a possible SA or SB bit write race condition, the SA and SB bits should not be modified using bit operations.

- 2:** These bits are only present in dsPIC33E devices. Please refer to the specific device data sheet for availability.
- 3:** The IPL<2:0> bits are concatenated with the IPL<3> bit (CORCON<3>) to form the CPU Interrupt Priority Level. The value in parentheses indicates the IPL, if IPL<3> = 1. User interrupts are disabled when IPL<3> = 1.
- 4:** The IPL<2:0> status bits are read only when NSTDIS(INTCON1<15>) = 1 .

dsPIC33E/PIC24E Family Reference Manual

Register 2-2: CORCON: Core Control Register

U-0	U-0	R/W-0	R/W-0	R/W-0	R-0	R-0	R-0
—	—	US<1:0> ⁽²⁾		EDT ^(1,2)	DL<2:0> ⁽²⁾		
bit 15							bit 8

R/W-0	R/W-0	R/W-1	R/W-0	R/C-0	R-0	R/W-0	R/W-0
SATA ⁽²⁾	SATB ⁽²⁾	SATDW ⁽²⁾	ACCSAT ⁽²⁾	IPL3 ⁽³⁾	SFA	RND ⁽²⁾	IF ⁽²⁾
bit 7							bit 0

Legend:

R = Readable bit W = Writable bit U = Unimplemented bit, read as '0'
 -n = Value at POR '1' = Bit is set '0' = Bit is cleared x = Bit is unknown

- bit 15-14 **Unimplemented:** Read as '0'
- bit 13-12 **US<1:0>:** DSP Multiply Unsigned/Signed Control bits
 - 11 = Reserved
 - 10 = DSP engine multiplies are mixed-sign
 - 01 = DSP engine multiplies are unsigned
 - 00 = DSP engine multiplies are signed
- bit 11 **EDT:** Early DO Loop Termination Control bit⁽¹⁾
 - 1 = Terminate executing DO loop at end of current loop iteration
 - 0 = No effect
- bit 10-8 **DL<2:0>:** DO Loop Nesting Level Status bits
 - 111 = 7 DO loops active
 -
 -
 -
 - 001 = 1 DO loop active
 - 000 = 0 DO loops active
- bit 7 **SATA:** AccA Saturation Enable bit
 - 1 = Accumulator A saturation enabled
 - 0 = Accumulator A saturation disabled
- bit 6 **SATB:** AccB Saturation Enable bit
 - 1 = Accumulator B saturation enabled
 - 0 = Accumulator B saturation disabled
- bit 5 **SATDW:** Data Space Write from DSP Engine Saturation Enable bit
 - 1 = Data space write saturation enabled
 - 0 = Data space write saturation disabled
- bit 4 **ACCSAT:** Accumulator Saturation Mode Select bit
 - 1 = 9.31 saturation (super saturation)
 - 0 = 1.31 saturation (normal saturation)
- bit 3 **IPL3:** CPU Interrupt Priority Level Status bit 3⁽³⁾
 - 1 = CPU interrupt priority level is greater than 7
 - 0 = CPU interrupt priority level is 7 or less

Note 1: This bit always reads as '0'.

2: These bits are only present in dsPIC33E devices. Please refer to the specific device data sheet for availability.

3: The IPL3 bit is concatenated with the IPL<2:0> bits (SR<7:5>) to form the CPU interrupt priority level.

Register 2-2: CORCON: Core Control Register (Continued)

- bit 2 **SFA:** Stack Frame Active Status bit
1 = Stack frame is active. W14 and W15 address 0x0000 to 0xFFFF, regardless of DSRPAG and DSWPAG values
0 = Stack frame is not active. W14 and W15 address of EDS or Base Data Space
- bit 1 **RND:** Rounding Mode Select bit
1 = Biased (conventional) rounding enabled
0 = Unbiased (convergent) rounding enabled
- bit 0 **IF:** Integer or Fractional Multiplier Mode Select bit
1 = Integer mode enabled for DSP multiply
0 = Fractional mode enabled for DSP multiply

Note 1: This bit always reads as '0'.

- 2:** These bits are only present in dsPIC33E devices. Please refer to the specific device data sheet for availability.
- 3:** The IPL3 bit is concatenated with the IPL<2:0> bits (SR<7:5>) to form the CPU interrupt priority level.

2.4.3 Other dsPIC33E/PIC24E CPU Control Registers

The following registers are associated with the dsPIC33E/PIC24E CPU, but are described in further detail in other sections of the “dsPIC33E/PIC24E Family Reference Manual”.

- **TBLPAG: Table Page Register**

The TBLPAG register holds the upper 8 bits of a program memory address during table read and write operations. Table instructions are used to transfer data between program memory space and data memory space. For further details, refer to **Section 4. “Program Memory”** (DS70613).

- **DSRPAG: Extended Data Space Read Page Register**

The 10-bit DSRPAG register extends X DS read access address space to a total of 32 Mbytes. DSRPAG page values between 0x001 and 0x1FF provide read access for a 16 Mbyte address space referred to as Extended Data Space (EDS). DSRPAG page values between 0x200 and 0x2FF provide read access from the 8 Mbyte PSV address space (for least significant word (lsw) reads only). DSRPAG page values between 0x300 and 0x3FF duplicate the 8 Mbyte PSV address space but allow user to read the Most Significant upper byte of each PSV address. For further details on the DSRPAG register, refer to **Section 3. “Data Memory”** (DS70595).

- **DSWPAG: Extended Data Space Write Page Register**

The 9-bit DSWPAG register extends DS write access space to 16 Mbytes (writes to PSV space are not permitted). DSWPAG page values between 0x01 and 0x1FF provide write access to EDS. For further details on the DSWPAG register, refer to **Section 3. “Data Memory”** (DS70595).

- **MODCON: Modulo Control Register**

The MODCON register enables and configures modulo addressing (circular buffers). For further details on modulo addressing, refer to **Section 3. “Data Memory”** (DS70595).

- **XMODSRT, XMODEND: X Modulo Start and End Address Registers**

The XMODSRT and XMODEND registers hold the start and end addresses for modulo (circular) buffers implemented in the X data memory address space. For further details on module addressing, refer to **Section 3. “Data Memory”** (DS70595).

- **YMODSRT, YMODEND: Y Modulo Start and End Address Registers**

The YMODSRT and YMODEND registers hold the start and end addresses for modulo (circular) buffers implemented in the Y data memory address space. For further details on module addressing, refer to **Section 3. “Data Memory”** (DS70595).

- **XBREV: X Modulo Bit-Reverse Register**

The XBREV register sets the buffer size used for bit-reversed addressing. For further details on bit-reversed addressing, refer to **Section 3. “Data Memory”** (DS70595).

- **DISICNT: Disable Interrupts Count Register**

The DISICNT register is used by the `DISI` instruction to disable interrupts of priority 1-6 for a specified number of cycles. For further information, refer to **Section 6. “Interrupts”** (DS70600).

2.5 ARITHMETIC LOGIC UNIT (ALU)

The dsPIC33E/PIC24E ALU is 16 bits wide and is capable of addition, subtraction, single bit shifts and logic operations. Unless otherwise mentioned, arithmetic operations are 2's complement in nature. Depending on the operation, the ALU can affect the values of these bits in the SR register:

- Carry (C)
- Zero (Z)
- Negative (N)
- Overflow (OV)
- Digit Carry (DC)

The C and DC status bits operate as Borrow and Digit Borrow bits, respectively, for subtraction.

The ALU can perform 8-bit or 16-bit operations, depending on the mode of the instruction that is used. Data for the ALU operation can come from the W register array or data memory depending on the Addressing mode of the instruction. Likewise, output data from the ALU can be written to the W register array or a data memory location.

For information on the SR bits affected by each instruction, Addressing modes, and 8-bit/16-bit Instruction modes, refer to the *"16-bit MCU and DSC Programmer's Reference Manual"* (DS70157).

Note 1: Byte operations use the 16-bit ALU and can produce results in excess of 8 bits. However, to maintain backward compatibility with PIC MCU devices, the ALU result from all byte operations is written back as a byte (i.e., MSB is not modified), and the SR register is updated based only upon the state of the LSB of the result.

2: All register instructions performed in Byte mode affect only the LSB of the W registers. The MSB of any W register can be modified by using file register instructions that access the memory mapped contents of the W registers.

2.5.1 Byte to Word Conversion

The dsPIC33E/PIC24E has two instructions that are helpful when mixing 8-bit and 16-bit ALU operations.

- The Sign-extend (SE) instruction takes a byte value in a W register or data memory and creates a sign-extended word value that is stored in a W register.
- The Zero-extend (ZE) instruction clears the 8 MSBs of a word value in a W register or data memory and places the result in a destination W register.

2.6 DSP ENGINE

The DSP engine is a block of hardware that is fed data from the W register array, but contains its own specialized result registers. The DSP engine is driven from the same instruction decoder that directs the MCU ALU. In addition, all operand EAs are generated in the W register array. Concurrent operation with MCU instruction flow is not possible, though both the MCU ALU and DSP engine resources can be shared by all instructions in the instruction set.

The DSP engine consists of the following components:

- High speed 17-bit by 17-bit multiplier
- Barrel shifter
- 40-bit Adder/Subtractor
- Two target accumulator registers
- Rounding logic with selectable modes
- Saturation logic with selectable modes

Data input to the DSP engine is derived from one of the following sources:

- Directly from the W array (registers W4, W5, W6 or W7) for dual source operand DSP instructions. Data values for the W4, W5, W6 and W7 registers are prefetched via the X and Y memory data buses
- From the X memory data bus for all other DSP instructions

Data output from the DSP engine is written to one of the following destinations:

- The target accumulator, as defined by the DSP instruction being executed
- The X memory data bus to any location in the data memory address space

The DSP engine can perform inherent accumulator-to-accumulator operations that require no additional data.

The MCU shift and multiply instructions use the DSP engine hardware to obtain their results. The X memory data bus is used for data reads and writes in these operations.

Figure 2-8 illustrates a block diagram of the DSP engine.

<p>Note: For detailed code examples and instruction syntax related to this section, refer to the “16-bit MCU and DSC Programmer’s Reference Manual” (DS70157).</p>

Figure 2-8: DSP Engine Block Diagram

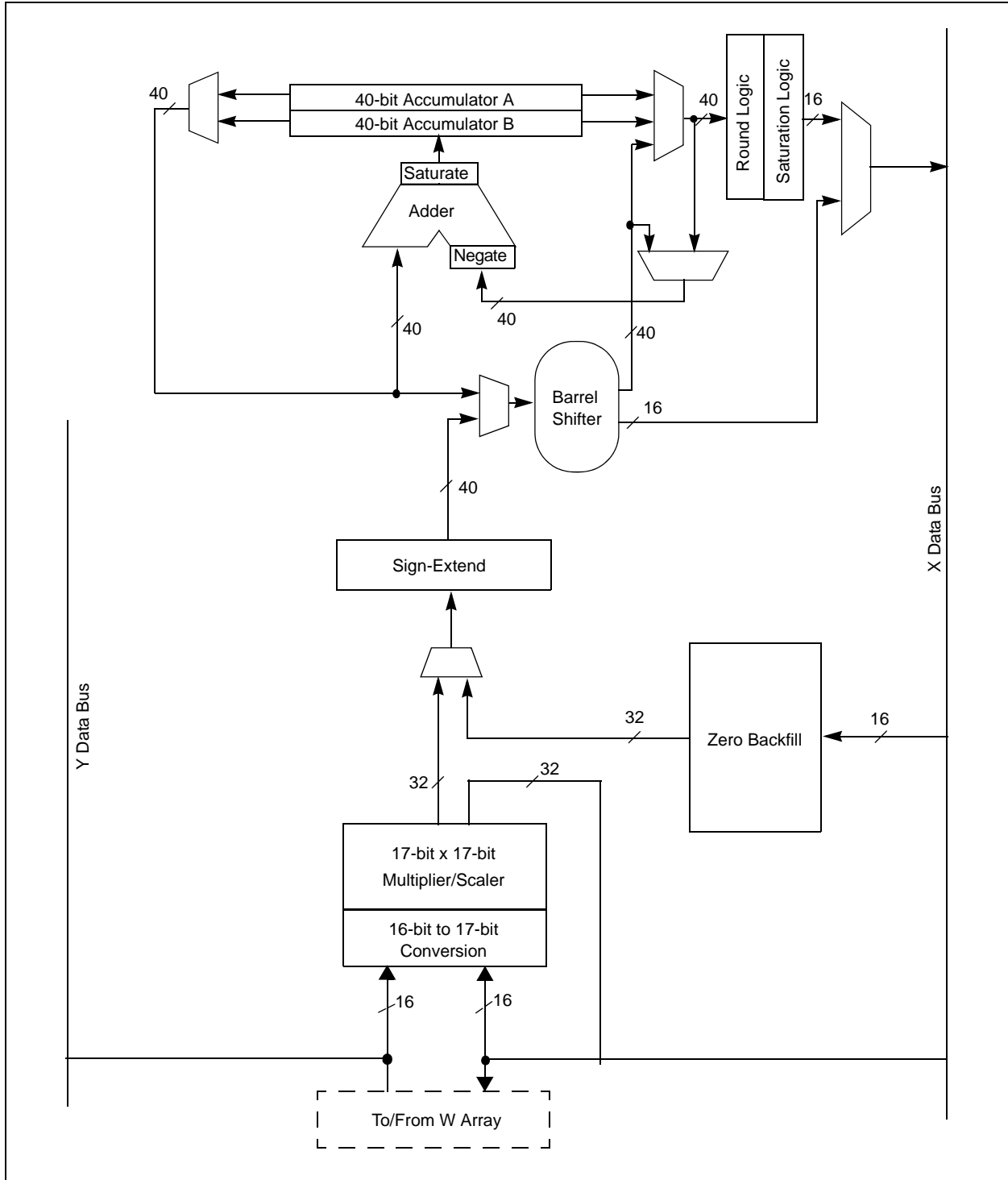

2.6.1 Data Accumulators (dsPIC33E Devices Only)

Two 40-bit data accumulators, ACCA and ACCB, are the result registers for the DSP instructions listed in Table 2-3. Each accumulator is memory mapped to these three registers, where 'x' denotes the particular accumulator:

- ACCxL: ACCx<15:0>
- ACCxH: ACCx<31:16>
- ACCxU: ACCx<39:32>

For fractional operations that use the accumulators, the radix point is located to the right of bit 31. The range of fractional values that can be stored in each accumulator is -256.0 to $(256.0 - 2^{-31})$.

For integer operations that use the accumulators, the radix point is located to the right of bit 0. The range of integer values that can be stored in each accumulator is $-549,755,813,888$ to $549,755,813,887$.

2.6.2 Multiplier

The dsPIC33E/PIC24E features a 17-bit-by-17-bit multiplier shared by both the MCU ALU and the DSP engine. The multiplier is capable of signed, unsigned, or mixed-sign operation and supports either 1.31 fractional (Q.31) or 32-bit integer results.

The multiplier takes in 16-bit input data and converts the data to 17 bits. Signed operands to the multiplier are sign-extended. Unsigned input operands are zero-extended. The internal 17-bit representation of data in the multiplier allows correct execution of mixed-sign and unsigned 16-bit-by-16-bit multiplication operations.

The representation of data in hardware for Integer and Fractional Multiplier modes is as follows:

- Integer data is inherently represented as a signed two's complement value, where the Most Significant bit (MSb) is defined as a sign bit. Generally speaking, the range of an N-bit two's complement integer is -2^{N-1} to $2^{N-1} - 1$.
- Fractional data is represented as a two's complement fraction where the MSb is defined as a sign bit and the radix point is implied to lie just after the sign bit (Q.X format). The range of an N-bit two's complement fraction with this implied radix point is -1.0 to $(1 - 2^{1-N})$.

The range of data in both Integer and Fractional modes is listed in Table 2-2. Figure 2-9 and Figure 2-10 illustrate how the multiplier hardware interprets data in Integer and Fractional modes.

The Integer or Fractional Multiplier Mode Select (IF) bit (CORCON<0>) determines integer/fractional operation for the instructions listed in Table 2-3. The IF bit does not affect MCU multiply instructions listed in Table 2-4, which are always integer operations. The multiplier scales the result one bit to the left for fractional operation. The LSb of the result is always cleared. The multiplier defaults to Fractional mode for DSP operations at a device Reset.

Table 2-2: dsPIC33E/PIC24E Data Ranges

Register Size	Integer Range	Fraction Range	Fraction Resolution
16-bit	-32768 to 32767	-1.0 to $(1.0 - 2^{-15})$ (Q.15 Format)	3.052×10^{-5}
32-bit	-2,147,483,648 to 2,147,483,647	-1.0 to $(1.0 - 2^{-31})$ (Q.31 Format)	4.657×10^{-10}
40-bit	-549,755,813,888 to 549,755,813,887	-256.0 to $(256.0 - 2^{-31})$ (Q.31 Format with 8 Guard bits)	4.657×10^{-10}

Figure 2-9: Integer and Fractional Representation of 0x4001

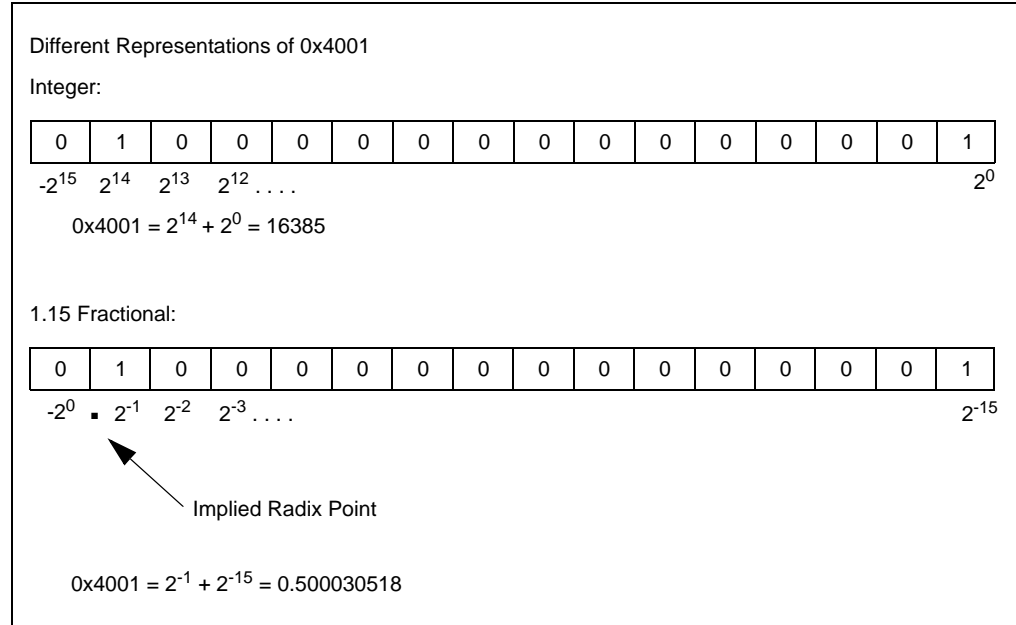
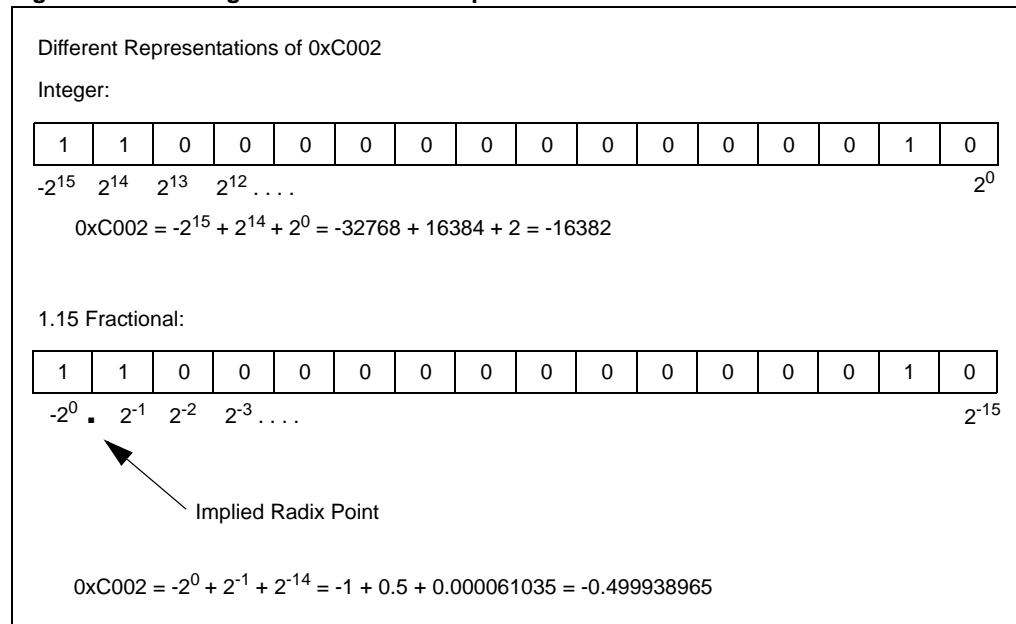

Figure 2-10: Integer and Fractional Representation of 0xC002



2.6.2.1 DSP MULTIPLY INSTRUCTIONS (dsPIC33E DEVICES ONLY)

The DSP instructions that use the multiplier are summarized in Table 2-3.

Table 2-3: DSP Instructions that Use the Multiplier

DSP Instruction	Description	Algebraic Equivalent
MAC	Multiply and Add to Accumulator or Square and Add to Accumulator	$a = a + b * c$ $a = a + b^2$
MSC	Multiply and Subtract from Accumulator	$a = a - b * c$
MPY	Multiply	$a = b * c$
MPY.N	Multiply and Negate Result	$a = -b * c$
ED	Partial Euclidean Distance	$a = (b - c)^2$
EDAC	Add Partial Euclidean Distance to the Accumulator	$a = a + (b - c)^2$

Note 1: DSP instructions using the multiplier can operate in Fractional (1.15) or Integer modes.

The DSP Multiplier Unsigned/Signed Control (US) bits (CORCON<13:12>) determine whether DSP multiply instructions are signed (default), unsigned or mixed-sign. The US bits do not influence the MCU multiply instructions, which have specific instructions for signed or unsigned operation. If the US bits are set to '01', the input operands for instructions shown in Table 2-3 are considered as unsigned values, which are always zero-extended into the 17th bit of the multiplier value. If the US bits are set to '00', the operands are sign-extended.

If the US bits (CORCON<13:12>) are set to '10', the operands for the instructions listed above, are considered as signed or unsigned values depending upon the W register source. If the W register source is odd (W5 or W7), the operand is assumed to be signed. If the W register source is even, the operand is assumed to be unsigned. The result is sign-extended if one or both of the operands are signed, otherwise it is zero extended prior to any operation with the accumulator (which will always effectively be signed).

2.6.2.2 MCU MULTIPLY INSTRUCTIONS

The same multiplier supports the MCU multiply instructions, which include integer 16-bit signed, unsigned and mixed sign multiplies, as shown in Table 2-4. All multiplications performed by the MUL instruction produce integer results. The MUL instruction can be directed to use byte or word sized operands. Byte input operands produce a 16-bit result and word input operands produce either a 16-bit result or a 32-bit result, either to the specified register(s) in the W array, or to an Accumulator.

Table 2-4: MCU Instructions that Utilize the Multiplier

MCU Instruction	Description
MUL/MUL.UU	Multiply two unsigned integers and generate 32-bit results.
MUL.SS	Multiply two signed integers and generate 32-bit results.
MUL.SU/MUL.US	Multiply a signed integer with an unsigned integer and generate 32-bit results.
MULW.UU	Multiply two unsigned integers and generate 16-bit results.
MULW.SS	Multiply two signed integers and generate 16-bit results.
MULW.SU/MULW.US	Multiply a signed integer with an unsigned integer and generate a 16-bit result.

Note 1: MCU instructions using the multiplier operate only in Integer mode.

2.6.3 Data Accumulator Adder/Subtractor

The data accumulators have a 40-bit Adder/Subtractor with automatic sign extension logic for the multiplier result (if signed). It can select one of two accumulators (A or B) as its pre-accumulation source and post-accumulation destination. For the `ADD` (accumulator) and `LAC` instructions, the data to be accumulated or loaded can optionally be scaled via the barrel shifter prior to accumulation.

The 40-bit Adder/Subtractor can optionally negate one of its operand inputs to change the sign of the result (without changing the operands). The negate is used during multiply and subtract (`MSC`), or multiply and negate (`MPY.N`) operations.

The 40-bit Adder/Subtractor has an additional saturation block that controls accumulator data saturation, if enabled.

2.6.3.1 ACCUMULATOR STATUS BITS

Six status register bits that support saturation and overflow are located in the CPU Status register (SR), and are listed in Table 2-5:

Table 2-5: Accumulator Overflow and Saturation Status Bits

Status Bit	Location	Description
OA	SR<15>	Accumulator A overflowed into guard bits (ACCA<39:32>)
OB	SR<14>	Accumulator B overflowed into guard bits (ACCB<39:32>)
SA	SR<13>	ACCA saturated (bit 31 overflow and saturation) or ACCA overflowed into guard bits and saturated (bit 39 overflow and saturation)
SB	SR<12>	ACCB saturated (bit 31 overflow and saturation) or ACCB overflowed into guard bits and saturated (bit 39 overflow and saturation)
OAB	SR<11>	OA logically ORed with OB. Clearing OAB clears both OA and OB.
SAB	SR<10>	SA logically ORed with SB. Clearing SAB clears both SA and SB.

The OA and OB bits are modified each time data passes through the accumulator add/subtract logic. When set, they indicate that the most recent operation has overflowed into the accumulator guard bits (bits 32 through 39). This type of overflow is not catastrophic; the guard bits preserve the accumulator data. The OAB status bit is the logically OR value of OA and OB.

The OA and OB bits, when set, can optionally generate an arithmetic error trap. The trap is enabled by setting the corresponding Overflow Trap Flag Enable bit (OVATE or OVBTE) in Interrupt Control Register 1 (INTCON1<10> or <9>) in the Interrupt controller. The trap event allows the user to take immediate corrective action, if desired.

The SA and SB bits can be set each time data passes through the accumulator saturation logic. Once set, these bits remain set until cleared by the user application. The SAB status bit indicates the logical OR value of SA and SB. When set, these bits indicate that the accumulator has overflowed its maximum range (bit 31 for 32-bit saturation or bit 39 for 40-bit saturation) and are saturated (if saturation is enabled).

When saturation is not enabled, the SA and SB bits indicate that a catastrophic overflow has occurred (the sign of the accumulator has been destroyed). If the Catastrophic Overflow Trap Enable (COVTE) bit (INTCON1<8>) is set, SA and SB bits will generate an arithmetic error trap when saturation is disabled. The SA and SB bits can be set in software, enabling efficient context state switching. For further information on arithmetic warning traps, refer to **Section 6. “Interrupts”** (DS70600).

Note: The SA, SB and SAB status bits can have different meanings depending on whether accumulator saturation is enabled. The Accumulator Saturation mode is controlled via the CORCON register.

2.6.3.2 SATURATION AND OVERFLOW MODES

The dsPIC33E/PIC24E CPU supports three Saturation and Overflow modes.

- **Accumulator 39-bit Saturation:**

In this mode, the saturation logic loads the maximally positive 9.31 value (0x7FFFFFFF), or maximally negative 9.31 value (0x80000000), into the target accumulator. The SA or SB bit is set and remains set until cleared by the user application. This Saturation mode is useful for extending the dynamic range of the accumulator.

To configure for this mode of saturation, set the Accumulator Saturation Mode Select (ACCSAT) bit (CORCON<4>). Additionally, set the AccA Saturation Enable (SATA) bit (CORCON<7>, and/or the AccB Saturation Enable (SATB) bit (CORCON<6>) to enable accumulator saturation.

- **Accumulator 31-bit Saturation:**

In this mode, the saturation logic loads the maximally positive 1.31 value (0x007FFFFFFF) or maximally negative 1.31 value (0xFF800000) into the target accumulator. The SA or SB bit is set and remains set until cleared by the user. When this Saturation mode is in effect, the guard bits 32 through 39 are not used except for sign-extension of the accumulator value. Consequently, the OA, OB or OAB bits in SR are never set.

To configure for this mode of overflow and saturation, the ACCSAT (CORCON<4>) bit must be cleared. Additionally, the SATA (CORCON<7>) and/or SATB (CORCON<6>) bits must be set to enable accumulator saturation.

- **Accumulator Catastrophic Overflow:**

If the SATA (CORCON<7>) and/or SATB (CORCON<6>) bits are not set, then no saturation operation is performed on the accumulator, and the accumulator is allowed to overflow all the way up to bit 39 (destroying its sign). If the Catastrophic Overflow Trap Enable (COVTE) bit (INTCON1<8> in the Interrupt controller) is set, a catastrophic overflow initiates an arithmetic error trap.

Accumulator saturation and overflow detection can only result from the execution of a DSP instruction that modifies one of the two accumulators via the 40-bit DSP ALU. Saturation and overflow detection do not take place when the accumulators are accessed as memory mapped registers via MCU class instructions. Furthermore, the accumulator status bits shown in Table 2-5 are not modified. However, the MCU status bits (Z, N, C, OV, DC) will be modified, depending on the MCU instruction that accesses the accumulator. For further information on arithmetic error traps, refer to **Section 6. “Interrupts”** (DS70600).

2.6.3.3 DATA SPACE WRITE SATURATION

In addition to Adder/Subtractor saturation, writes to data space can be saturated without affecting the contents of the source accumulator. This feature allows data to be limited, while not sacrificing the dynamic range of the accumulator during intermediate calculation stages. Data space write saturation is enabled by setting the Data Space Write from DSP Engine Saturation Enable (SATDW) control bit (CORCON<5>). Data space write saturation is enabled by default at a device Reset.

The data space write saturation feature works with the `SAC` and `SAC.R` instructions. The value held in the accumulator is never modified when these instructions are executed. The hardware takes the following steps to obtain the saturated write result:

1. The read data is scaled based upon the arithmetic shift value specified in the instruction.
2. The scaled data is rounded (`SAC.R` only).
3. The scaled/rounded value is saturated to a 16-bit result based on the value of the guard bits. For data values greater than 0x007FFF, the data written to memory is saturated to the maximum positive 1.15 value, 0x7FFF. For input data less than 0xFF8000, data written to memory is saturated to the maximum negative 1.15 value, 0x8000.

2.6.3.4 ACCUMULATOR 'WRITE BACK'

The `MAC` and `MSC` instructions can optionally write a rounded version of the accumulator that is not the target of the current operation into data space memory. The write is performed across the X bus into combined X and Y address space. This accumulator write-back feature is beneficial in certain algorithms, such as FFT and LMS filters.

The following Addressing modes are supported by the accumulator write back hardware:

- `W13`, register direct:

The rounded contents of the non-target accumulator are written into `W13` as a 1.15 fractional result.

- `[W13]+ = 2`, register indirect with post-increment:

The rounded contents of the non-target accumulator are written into the address pointed to by `W13` as a 1.15 fraction. `W13` is then incremented by 2.

2.6.4 Round Logic (dsPIC33E Devices Only)

The round logic can perform a conventional (biased) or convergent (unbiased) round function during an accumulator write (store). The Round mode is determined by the state of the Rounding Mode Select (`RND`) bit (`CORCON<1>`). It generates a 16-bit, 1.15 data value, which is passed to the data space write saturation logic. If rounding is not indicated by the instruction, a truncated 1.15 data value is stored.

The two Rounding modes are shown in Figure 2-11. Conventional rounding takes bit 15 of the accumulator, zero-extends it and adds it to the most significant word (`msw`), excluding the guard or overflow bits (bits 16 through 31). If the least significant word (`lsw`) of the accumulator is between `0x8000` and `0xFFFF` (`0x8000` included), the `msw` is incremented. If the `lsw` of the accumulator is between `0x0000` and `0x7FFF`, the `msw` remains unchanged. A consequence of this algorithm is that over a succession of random rounding operations, the value tends to be biased slightly positive.

Convergent (or unbiased) rounding operates in the same manner as conventional rounding except when the `lsw` equals `0x8000`. If this is the case, the `LSb` of the `msw` (bit 16 of the accumulator) is examined. If it is '1', the `msw` is incremented. If it is '0', the `msw` is not modified. Assuming that bit 16 is effectively random in nature, this scheme removes any rounding bias that may accumulate.

The `SAC` and `SAC.R` instructions store either a truncated (`SAC`) or rounded (`SAC.R`) version of the contents of the target accumulator to data memory via the X-bus (subject to data saturation). For more information, refer to 2.6.3.3 "Data Space Write Saturation".

For the `MAC` class of instructions, the accumulator write-back data path is always subject to rounding.

Figure 2-11: Conventional and Convergent Rounding Modes

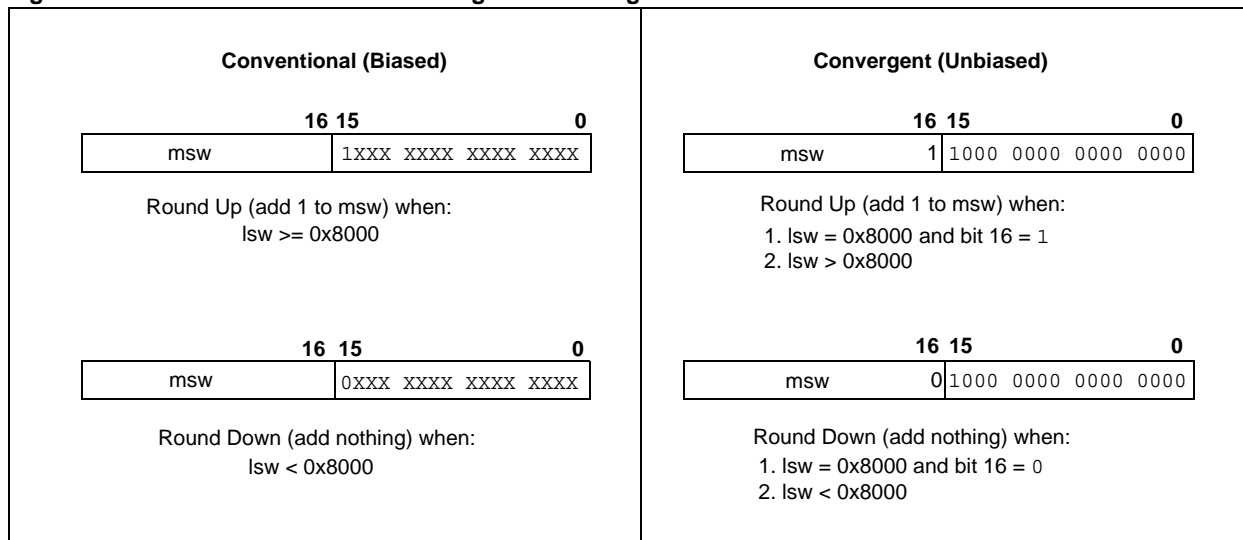

2.6.5 Barrel Shifter (dsPIC33E Devices Only)

The Barrel Shifter can perform up to a 16-bit arithmetic right shift, or up to a 16-bit left shift, in a single cycle. DSP or MSU instructions can use the barrel shifter for multi-bit shifts.

The shifter requires a signed binary value to determine both the magnitude (number of bits) and direction of the shift operation:

- A positive value shifts the operand right
- A negative value shifts the operand left
- A value of '0' does not modify the operand

The barrel shifter is 40 bits wide to accommodate the width of the accumulators. A 40-bit output result is provided for DSP shift operations and a 16-bit result is provided for MCU shift operations.

Table 2-6 provides a summary of instructions that use the barrel shifter.

Table 2-6: Instructions that Use the DSP Engine Barrel Shifter

Instruction	Description
ASR	Arithmetic multi-bit right shift of data memory location.
LSR	Logical multi-bit right shift of data memory location.
SL	Multi-bit shift left of data memory location.
SAC	Store DSP accumulator with optional shift.
SFTAC	Shift DSP accumulator.

2.6.6 DSP Engine Mode Selection (dsPIC33E Devices Only)

These operational characteristics of the DSP engine discussed in previous sections can be selected through the CPU Core Configuration register (CORCON):

- Fractional or integer multiply operation
- Conventional or convergent rounding
- Automatic saturation on/off for ACCA
- Automatic saturation on/off for ACCB
- Automatic saturation on/off for writes to data memory
- Accumulator Saturation mode selection

2.6.7 DSP Engine Trap Events (dsPIC33E Devices Only)

Arithmetic error traps that can be generated for handling exceptions in the DSP engine are selected through the Interrupt Control register (INTCON1). These are:

- Trap on ACCA overflow enable, using OVATE (INTCON1<10>)
- Trap on ACCB overflow enable, using OVBTE (INTCON1<9>)
- Trap on catastrophic ACCA and/or ACCB overflow enable, using COVTE (INTCON1<8>)

Occurrence of the traps is indicated by these error status bits:

- OVAERR (INTCON1<14>)
- OVBERR (INTCON1<13>)
- COVAERR (INTCON1<12>)
- COVBERR (INTCON1<11>)

An arithmetic error trap is also generated when the user application attempts to shift a value beyond the maximum allowable range (± 16 bits) using the *SFTAC* instruction. This trap source cannot be disabled, and is indicated by the Shift Accumulator Error Status (SFTACERR) bit (INTCON1<7> in the Interrupt controller). The instruction will execute, but the results of the shift are not written to the target accumulator.

For further information on bits in the INTCON1 register and arithmetic error traps, refer to **Section 6. “Interrupts”** (DS70600).

2.7 DIVIDE SUPPORT

The dsPIC33E/PIC24E supports the following types of division operations:

- `DIVF`: 16/16 signed fractional divide (dsPIC33E devices only)
- `DIV.SD`: 32/16 signed divide
- `DIV.UD`: 32/16 unsigned divide
- `DIV.SW`: 16/16 signed divide
- `DIV.UW`: 16/16 unsigned divide

The quotient for all divide instructions is placed in working register `W0`. The remainder is placed in `W1`. The 16-bit divisor can be located in any `W` register. A 16-bit dividend can be located in any `W` register and a 32-bit dividend must be located in an adjacent pair of `W` registers.

All divide instructions are iterative operations and must be executed 18 times within a `REPEAT` loop. The developer is responsible for programming the `REPEAT` instruction. A complete divide operation takes 19 instruction cycles to execute.

The divide flow is interruptible, just like any other `REPEAT` loop. All data is restored into the respective data registers after each iteration of the loop, so the user application is responsible for saving the appropriate `W` registers in the ISR. Although they are important to the divide hardware, the intermediate values in the `W` registers have no meaning to the user application. The divide instructions must be executed 18 times in a `REPEAT` loop to produce a meaningful result.

A divide-by-zero error generates a math error trap. This condition is indicated by the Math Error Status (`DIV0ERR`) bit (`INTCON1<6>` in the Interrupt controller).

For more information and programming examples for the divide instructions, refer to the “*16-bit MCU and DSC Programmer’s Reference Manual*” (DS70157).

2.8 INSTRUCTION FLOW TYPES

Most instructions in the dsPIC33E/PIC24E architecture occupy a single word of program memory and execute in a single cycle. An instruction pre-fetch mechanism facilitates single cycle (1 Tcy) execution. However, some instructions take two or more instruction cycles to execute. Consequently, there are seven different types of instruction flow in the dsPIC[®] DSC architecture. These are described in this section.

2.8.1 1 Instruction Word, 1 Instruction Cycle

These instructions take one instruction cycle to execute, as shown in Figure 2-12. Most instructions are 1-word, 1-cycle instructions.

Figure 2-12: Instruction Flow – 1-Word, 1-Cycle

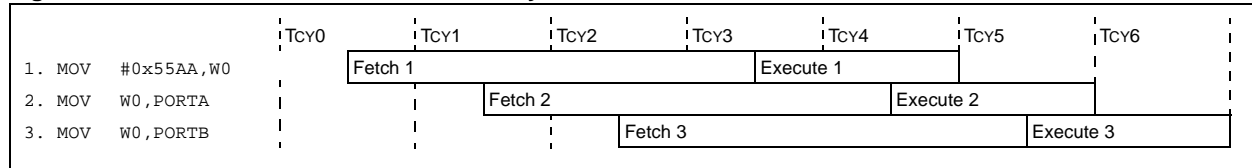

2.8.2 1 Instruction Word, 2 Instruction Cycles

In these instructions, there is no pre-fetch flush. The only instructions of this type are the MOV.D instructions (load and store double-word), SFR reads, and SFR bit operations. Two cycles are required to complete these instructions, as shown in Figure 2-13.

Figure 2-13: Instruction Flow – 1-Word, 2-Cycle (MOV.D Operation)

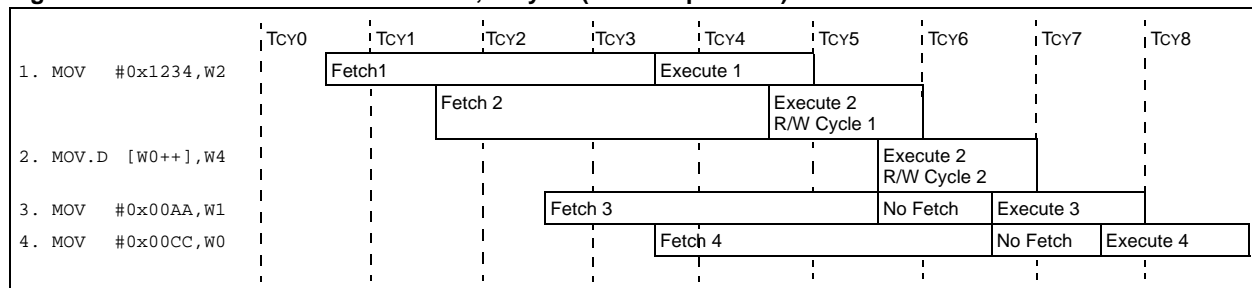

2.8.3 1 Instruction Word, 2 or 4 Instruction Cycle (Program Flow Changes)

These instructions include relative call and branch instructions. When an instruction changes the PC (other than to increment it), the program memory prefetch data must be discarded. This makes the instruction take four effective cycles to execute, as shown in Figure 2-14.

Figure 2-14: Instruction Flow (Program Flow Changes)

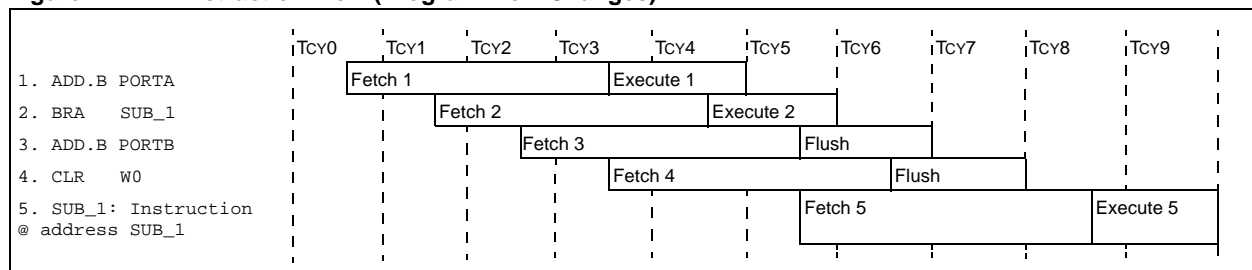

2.8.4 Table Read/Write Instructions

These instructions suspend fetching to insert a read or write cycle to the program memory. Figure 2-15 illustrates the instruction fetched while executing the table operation is saved for one cycle and executed in the cycle immediately after the table operation.

Figure 2-15: Instruction Flow (Table Operations)

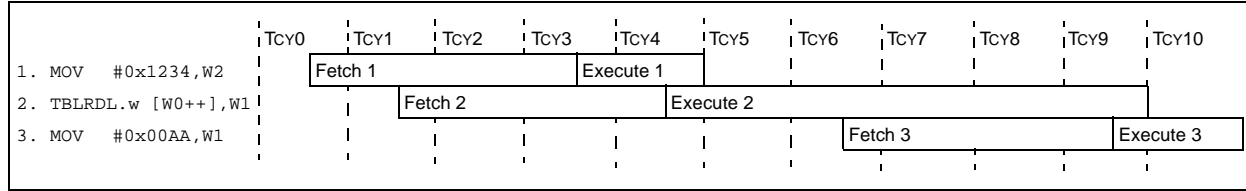

2.8.5 2 Instruction Words, 4 Instruction Cycles – GOTO or CALL

In these instructions, the fetch after the instruction contains data. This results in a 4-cycle instruction, as shown in Figure 2-16. The second word of a two-word instruction is encoded so that it executes as a NOP if it is fetched by the CPU when the CPU did not first fetch the first word of the instruction. This is important when a two-word instruction is skipped by a skip instruction (see Figure 2-16).

Figure 2-16: Instruction Flow (GOTO or CALL)

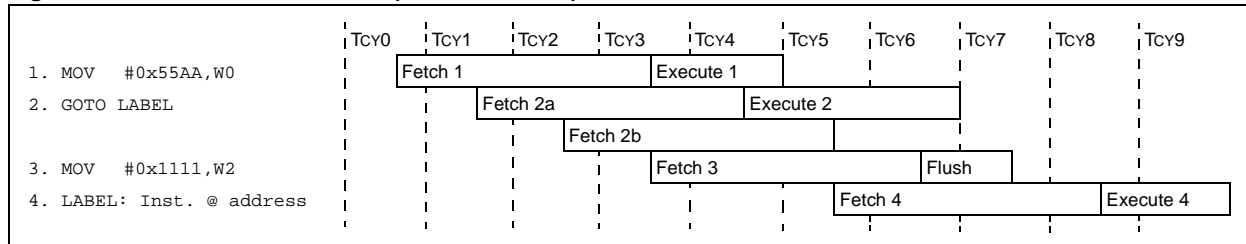

2.8.6 2 Instruction Words, 2 Instruction Cycles – DO

In this instruction, the fetch after the instruction contains an address offset. This address offset is added to the first instruction address to generate the last loop instruction address.

Figure 2-17: Instruction Flow (DO)

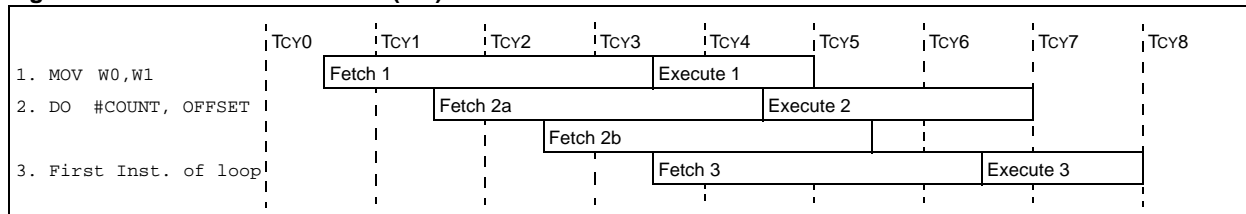

2.8.7 Address Register Dependencies

These are instructions subjected to a stall due to a data address dependency between the X-data space read and write operations. An additional cycle is inserted to resolve the resource conflict, as discussed in 2.10 “Address Register Dependencies”.

Figure 2-18: Instruction Pipeline Flow – 1-Word, 1-Cycle (With Instruction Stall)

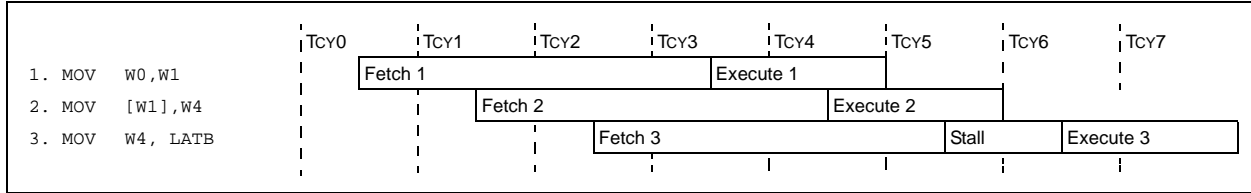

2.8.8 Interrupt Processing

The instruction pipeline flow for interrupt processing is described in detail in Section 6. “Interrupts” (DS70600).

2.9 LOOP CONSTRUCTS

The dsPIC33E/PIC24E supports both REPEAT and DO instruction constructs to provide unconditional automatic program loop control. The REPEAT instruction implements a single instruction program loop. The DO instruction implements a multiple instruction program loop. Both instructions use control bits within the CPU Status register (SR) to temporarily modify CPU operation.

2.9.1 REPEAT Loop Construct

The REPEAT instruction causes the instruction that follows it to be repeated a specified number of times. A literal value contained in the instruction or a value in one of the W registers can be used to specify the REPEAT count value. The W register option enables the loop count to be a software variable.

An instruction in a REPEAT loop is executed at least once. The number of iterations for a REPEAT loop is the 15-bit literal value + 1, or Wn + 1.

The syntax for the two forms of the REPEAT instruction is:

```
REPEAT #lit15          ; RCOUNT <-- lit15
(Valid target Instruction)
```

or

```
REPEAT Wn             ; RCOUNT <-- Wn
(Valid target Instruction)
```

2.9.1.1 REPEAT OPERATION

The loop count for REPEAT operations is held in the 16-bit Repeat Loop Counter register(RCOUNT) , which is memory mapped. RCOUNT is initialized by the REPEAT instruction. The REPEAT instruction sets the REPEAT Loop Active (RA) status bit (SR<4>) to '1' if the RCOUNT is a non-zero value.

RA is a read-only bit and cannot be modified through software. For REPEAT loop count values greater than '0', the Program Counter is not incremented. Further, Program Counter increments are inhibited until RCOUNT = 0. For an instruction flow example of a REPEAT loop, refer to Figure 2-19.

For a loop count value equal to '0', REPEAT has the effect of a NOP and the RA (SR<4>) bit is not set. The REPEAT loop is essentially disabled before it begins, allowing the target instruction to execute only once while prefetching the subsequent instruction (i.e., normal execution flow).

Note: The instruction immediately following the REPEAT instruction (i.e., the target instruction) is always executed at least one time, and it is always executed one time more than the value specified in the 15-bit literal or the W register operand.

Figure 2-19: REPEAT Instruction Pipeline Flow

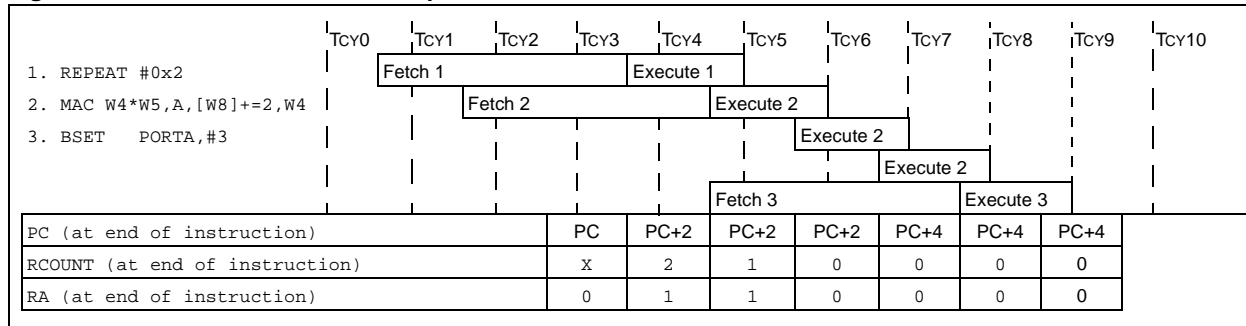

Note: A consequence of repeating the same instruction is that even when the repeated instruction is performing a PSV read, the first and last iteration incur 5 Tcy and 6 Tcy, respectively, due to Flash latency. All other iterations execute with an effective throughput of 1 instruction per cycle. However, this data pipelining is limited to certain addressing modes: post-increment or post-decrement by 1 or 2.

2.9.1.2 INTERRUPTING A REPEAT LOOP

A REPEAT instruction loop can be interrupted at any time.

The state of the RA bit is preserved on the stack during exception processing, to enable the user application to execute further REPEAT loops from within any number of nested interrupts. After SRL is stacked, the RA status bit is cleared to restore normal execution flow within the (ISR).

Note: If a REPEAT loop has been interrupted, and an ISR is being processed, the user application must stack the Repeat Count register (RCOUNT) before it executes another REPEAT instruction within an ISR.
If a REPEAT instruction is used within an ISR, the user application must unstack the RCOUNT register before it executes the RETFIE instruction.

Returning into a REPEAT loop from an ISR using the RETFIE instruction requires no special handling. Interrupts pre-fetch the repeated instruction during the fifth cycle of the RETFIE instruction. The stacked RA bit is restored when the SRL register is popped and, if set, the interrupted REPEAT loop is resumed.

2.9.1.2.1 Early Termination of a REPEAT Loop

An interrupted REPEAT loop can be terminated earlier than normal in the ISR by clearing the RCOUNT register in software.

2.9.1.3 RESTRICTIONS ON THE REPEAT INSTRUCTION

Any instruction can immediately follow a REPEAT except for the following:

- Program Flow Control instructions (any branch, compare and skip, subroutine calls, returns, etc.)
- Another REPEAT or DO instruction
- DISI, ULNK, LNK, PWRSAV or RESET
- MOV.D instruction

Note: Some instructions and/or instruction addressing modes can be executed within a REPEAT loop, but it might not make sense to repeat all instructions.

2.9.2 DO Loop Construct (dsPIC33E Devices Only)

The DO instruction can execute a group of instructions that follow it a specified number of times without software overhead. The set of instructions up to and including the end address are repeated. The repeat count value for the DO instruction can be specified by a 15-bit literal value +1 or by the contents of a W register +1 declared within the instruction.

The syntax for the 15-bit literal form of the DO instruction is:

```
DO      #lit15,LOOP_END      ; DCOUNT <-- lit15
Instruction1
Instruction2
      :
      :
LOOP_END: Instruction n
```

The syntax for the W register declared form of the DO instruction is:

```
DO      Wn,LOOP_END          ; DCOUNT <-- Wn<15:0>
Instruction1
Instruction2
      :
      :
LOOP_END: Instruction n
```

The following features are provided in the `DO` loop construct

- The first instruction of a `DO` loop cannot be a PSV read or a table read
- A `W` register can be used to specify the loop count, which allows the loop count to be defined at run-time
- The instruction execution order need not be sequential (i.e., there can be branches, subroutine calls, etc.)
- The loop end address need not be greater than the start address

2.9.2.1 `DO` LOOP REGISTERS AND OPERATION

The number of iterations executed by a `DO` loop will be the 15-bit literal value +1 or the `Wn` value + 1. If a `W` register is used to specify the number of iterations, the two MSBs are not used to specify the loop count. The operation of a `DO` loop is similar to the `DO-WHILE` construct in the C programming language because the instructions in the loop will always be executed at least once.

The dsPIC33E/PIC24E has three registers associated with `DO` loops:

- The `DO` Loop Start Address (`DOSTART`) register holds the starting address of the `DO` loop. It is a 22-bit register.
- The `DO` Loop End Address (`DOEND`) register holds the end address of the `DO` loop. It is a 22-bit register.
- The `DO` Loop Counter (`DCOUNT`) register holds the number of iterations to be executed by the loop. It is a 16-bit register.

These registers are memory mapped and are automatically loaded by the hardware when the `DO` instruction is executed. The MSb and LSb of these registers is fixed to '0'. The LSb is not stored in these registers because `PC<0>` is always forced to '0'.

The `DO` Loop Active (`DA`) status bit (`SR<9>`) indicates that a single `DO` loop (or nested `DO` loops) is active. When a `DO` instruction is executed, the `DA` bit is set, which enables the `PC` address to be compared with the `DOEND` register on each subsequent instruction cycle. When the `PC` matches the value in `DOEND`, `DCOUNT` is decremented.

If the `DCOUNT` register is not zero, the `PC` is loaded with the address contained in the `DOSTART` register to start another iteration of the `DO` loop. When `DCOUNT` reaches zero, the `DO` loop terminates.

If no other nested `DO` loops are in progress, the `DA` bit is also cleared. `DO` loops can be interrupted at any time.

Note: The group of instructions in a <code>DO</code> loop construct is always executed at least one time. The <code>DO</code> loop is always executed one time more than the value specified in the literal or <code>W</code> register operand.
--

2.9.2.2 `DO` LOOP NESTING

The `DOSTART`, `DOEND` and `DCOUNT` registers each have an associated hardware stack that allows the `DO` loop hardware to support up to three levels of nesting.

The `DO` Loop Nesting Level (`DL<2:0>`) status bits (`CORCON<10:8>`) indicate the nesting level of the `DO` loop currently being executed. When the first `DO` instruction is executed, `DL<2:0>` is set to `'b001'` to indicate that one level of `DO` loop is in progress. The `DO` Loop Active (`DA`) bit (`SR<9>`) is also set.

When another `DO` instruction is executed within the first `DO` loop, the `DOSTART`, `DOEND` and `DCOUNT` registers are transferred into the `DO` stack before they are updated with the new loop values. The `DL<2:0>` bits are set to `'b010'` to indicate that a second, nested `DO` loop is in progress. The `DA` (`SR<9>`) bit also remains set. This continues for subsequent nested `DO` loops.

The `DOSTART`, `DOEND` and `DCOUNT` registers are automatically restored from their `DO` stack when a `DO` loop terminates.

Note: The <code>DL<2:0></code> (<code>CORCON<10:8></code>) bits are combined (logically ORed) to form the <code>DA</code> (<code>SR<9></code>) bit. If nested <code>DO</code> loops are being executed, the <code>DA</code> bit is cleared only when the loop count associated with the outermost loop expires.
--

2.9.2.3 DO STACK

The DO stack is used to preserve the following elements associated with a DO loop underway when another DO loop is encountered (i.e., a nested DO loop).

- DOSTART register value
- DOEND register value
- DCOUNT register value
- First loop instruction
- Second loop instruction, or second word of first loop instruction if it is a 2-word instruction

Note that the DO level status field (DL<2:0>) also acts as a pointer to address the DO stack. After the DO is executed, DL<2:0> points to the next free entry.

The initial DO instruction executes without using the stack (actually stacks to a null (nonexistent) entry). Subsequent DO instructions start to fill up the DO stack until three entries are in place. At this point DL<2:0> = 4 after the final DO instruction has executed, indicating that the initial DO loop plus three nested DO loops are executing. No further DO loops may be nested.

If the user attempts to nest an additional DO loop when DL<2:0> = 4 (at the start of the instruction, prior to the DO level increment), the DO stack overflow bit, DO_OVR (INTCON3<4>), will be set and a generic soft trap is generated.

A conceptual representation of the DO stack is shown in Figure 2-20.

Figure 2-20: DO Stack Conceptual Diagram

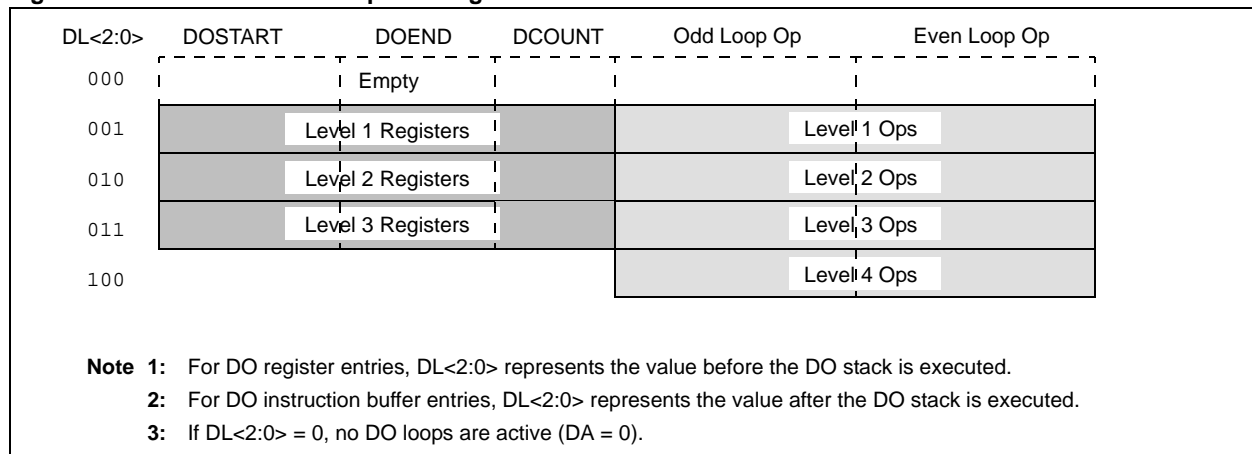

2.9.2.4 EARLY TERMINATION OF THE DO LOOP

There are two ways to terminate a DO loop earlier than normal:

- The Early DO Loop Termination Control (EDT) bit (CORCON<11>) provides a means for the user application to terminate a DO loop before it completes all loops. Writing a '1' to the EDT bit forces the loop to complete the iteration underway and then terminate. If EDT is set during the next-to-last (penultimate) or last instruction of the loop, one more iteration of the loop occurs. EDT always reads as a '0'; clearing it has no effect. After the EDT bit is set, the user can optionally branch out of the DO loop.
- Alternately, the code can branch out of the loop at any point except from the last two instructions, which cannot be a flow-control instruction. Although the DA (SR<9>) bit enables the DO loop hardware, it has no effect unless the address of the penultimate instruction is encountered during an instruction pre-fetch. This is not a recommended method for terminating a DO loop.

Note: Exiting a DO loop without using EDT is not recommended because the hardware will continue to check for DOEND addresses.

2.9.2.5 DO LOOP RESTRICTIONS

The use of DO loops imposes restrictions such as:

- When the DOEND register can be read
- Certain instructions must not be used as the last two instructions in the loop
- Certain small loop lengths are prohibited (loop length refers to the size of the block of instructions that is being repeated in the loop)

2.9.2.5.1 DOEND Register Restrictions

All DO loops must contain at least two instructions because the loop termination tests are performed in the penultimate instruction. REPEAT should be used for single instruction loops.

The special function register, DOEND, cannot be read by user software in the instruction that immediately follows either a DO instruction or a file register write operation to the DOEND SFR.

The instruction before the penultimate instruction in a DO loop should not modify:

- CPU priority level governed by the CPU Interrupt Priority Level (IPL) status bits (SR<7:5>)
- Peripheral Interrupt Enable bits governed by Interrupt Enable Control registers IECn
- Peripheral Interrupt Priority bits governed by Interrupt Priority Control registers IPCn

If these restrictions are not observed, the DO loop may execute incorrectly.

2.9.2.5.2 Restrictions on First Instruction

A PSV or table read cannot be the first instruction in the loop.

2.9.2.5.3 Restrictions on Last Two Instructions

The last two instructions in a DO loop should not be any of the following:

- Flow control instruction (e.g., any branch, compare and skip, GOTO, CALL, RCALL, TRAP)
- Another REPEAT or DO instruction
- Target instruction within a REPEAT loop. This restriction implies that the penultimate instruction also cannot be a REPEAT
- Any instruction that occupies two words in program space
- DISI instruction

RETURN, RETFIE and RETLW work correctly as one of the last two instructions of a DO loop, but the user application is responsible for returning to the loop to complete it.

2.9.2.5.4 Loop Length Restrictions

Loop length is defined as the signed offset of the last instruction from the first instruction in the DO loop. The loop length, when added to the address of the first instruction in the loop, forms the address of the last instruction of the loop. For example, a loop length of 1 implies a one-instruction loop. The loop length must not be -1, 0 or 1.

2.10 ADDRESS REGISTER DEPENDENCIES

The dsPIC33E/PIC24E architecture supports a data space read (source) and a data space write (destination) for most MCU class instructions. The EA calculation by the AGU, and subsequent data space read or write, each take one instruction cycle to complete. This timing causes the data space read and write operations for each instruction to partially overlap, as shown in Figure 2-21. A 'Read-After-Write' (RAW) data dependency can occur across instruction boundaries because of this overlap. RAW data dependencies are detected and handled at runtime by the dsPIC33E/PIC24E CPU.

Figure 2-21: Data Space Access Timing

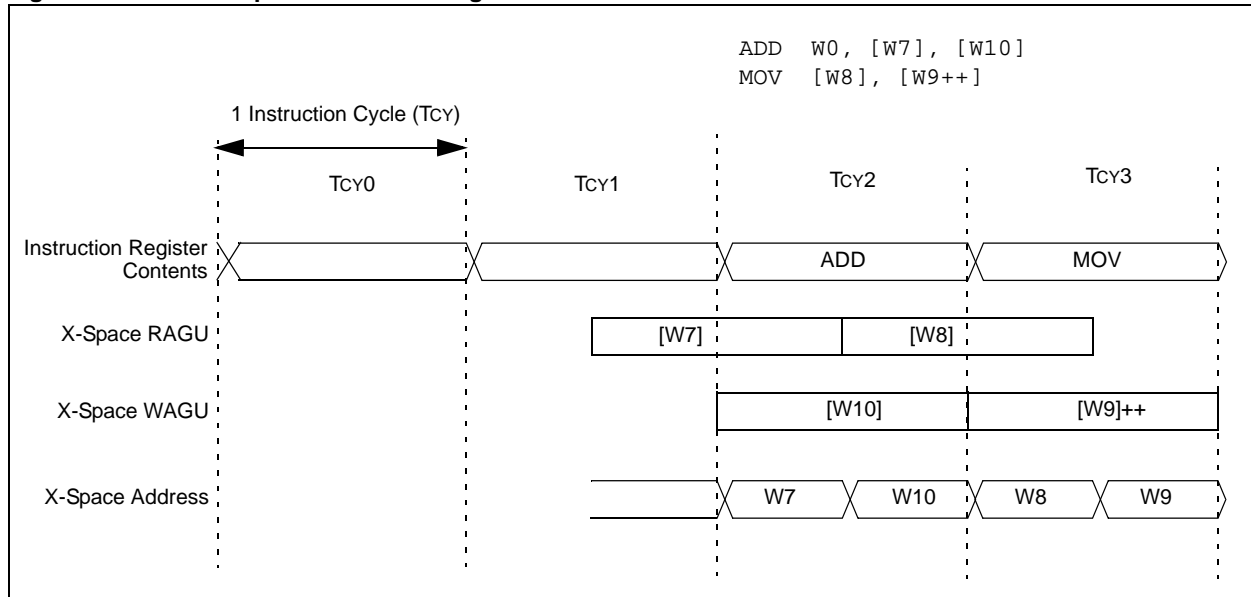

2.10.1 Read-After-Write Dependency Rules

If the W register is used as a write operation destination in the current instruction and the W register being read in the prefetched instruction are the same, the following rules apply:

- If the destination write (current instruction) does not modify the contents of W_n , no stalls will occur.
- If the source read (prefetched instruction) does not calculate an EA using W_n , no stalls will occur.

During each instruction cycle, the dsPIC33E/PIC24E hardware automatically checks to see if a RAW data dependency is about to occur. If the conditions specified above are not satisfied, the CPU automatically adds a one instruction cycle delay before executing the prefetched instruction. The instruction stall provides enough time for the destination W register write to occur before the next (prefetched) instruction uses the written data. Table 2-7 provides a summary of Read-After-Write Dependency.

Table 2-7: Read-After-Write Dependency Summary

Destination Addressing Mode Using Wn	Source Addressing Mode Using Wn	Status	Examples (Wn = W2)
Direct	Direct	Allowed	ADD.w W0, W1, W2 MOV.w W2, W3
Direct	Indirect	Stall	ADD.w W0, W1, W2 MOV.w [W2], W3
Direct	Indirect with modification	Stall	ADD.w W0, W1, W2 MOV.w [W2++], W3
Indirect	Direct	Allowed	ADD.w W0, W1, [W2] MOV.w W2, W3
Indirect	Indirect	Allowed	ADD.w W0, W1, [W2] MOV.w [W2], W3
Indirect	Indirect with modification	Allowed	ADD.w W0, W1, [W2] MOV.w [W2++], W3
Indirect with modification	Direct	Allowed	ADD.w W0, W1, [W2++] MOV.w W2, W3
Indirect	Indirect	Stall	ADD.w W0, W1, [W2] MOV.w [W2], W3 ; W2=0x0004 (mapped W2)
Indirect	Indirect with modification	Stall	ADD.w W0, W1, [W2] MOV.w [W2++], W3 ; W2=0x0004 (mapped W2)
Indirect with modification	Indirect	Stall	ADD.w W0, W1, [W2++] MOV.w [W2], W3
Indirect with modification	Indirect with modification	Stall	ADD.w W0, W1, [W2++] MOV.w [W2++], W3

2.10.2 Instruction Stall Cycles

An instruction stall is essentially a wait period instruction cycle, added in front of the read phase of an instruction, to allow the prior write to complete before the next read operation. For interrupt latency, the stall cycle is associated with the instruction following the instruction where it was detected (i.e., stall cycles always precede instruction execution cycles).

If a RAW data dependency is detected, the dsPIC33E/PIC24E begins an instruction stall. During an instruction stall, the following events occur:

- The write operation in progress (for the previous instruction), is allowed to complete as normal
- Data space is not addressed until after the instruction stall
- PC increment is inhibited until after the instruction stall
- Further instruction fetches are inhibited until after the instruction stall

2.10.2.1 INSTRUCTION STALL CYCLES AND INTERRUPTS

When an interrupt event coincides with two adjacent instructions that causes an instruction stall, one of two possible outcomes can occur:

- If the interrupt coincides with the first instruction, the first instruction is allowed to complete while the second instruction is executed after the ISR completes. In this case, the stall cycle is eliminated from the second instruction because the exception process provides time for the first instruction to complete the write phase.
- If the interrupt coincides with the second instruction, the second instruction and the appended stall cycle are allowed to execute before the ISR. In this case, the stall cycle associated with the second instruction executes normally. However, the stall cycle is effectively absorbed into the exception process timing. The exception process proceeds as if an ordinary two-cycle instruction was interrupted.

2.10.2.2 INSTRUCTION STALL CYCLES AND FLOW CHANGE INSTRUCTIONS

The `CALL` and `RCALL` instructions write to the stack using working register `W15` and can, therefore, force an instruction stall prior to the next instruction, if the source read of the next instruction uses `W15`.

The `RETFIE` and `RETURN` instructions can never force an instruction stall prior to the next instruction because they only perform read operations. However, the `RETLW` instruction can force a stall, because it writes to a `W` register during the last cycle.

The `GOTO` and branch instructions can never force an instruction stall because they do not perform write operations.

2.10.2.3 INSTRUCTION STALLS AND `DO` AND `REPEAT` LOOPS

Other than the addition of instruction stall cycles, RAW data dependencies do not affect the operation of either `DO` or `REPEAT` loops.

The prefetched instruction within a `REPEAT` loop does not change until the loop is complete or an exception occurs. Although register dependency checks occur across instruction boundaries, the dsPIC33E/PIC24E effectively compares the source and destination of the same instruction during a `REPEAT` loop.

The last instruction of a `DO` loop either pre-fetches the instruction at the loop start address or the next instruction (outside the loop). The instruction stall decision is based on the last instruction in the loop and the contents of the prefetched instruction.

2.10.2.4 INSTRUCTION STALLS AND PROGRAM SPACE VISIBILITY (PSV)

When Program Space (PS) is mapped to data space and the X space EA falls within the visible program space window, the read or write cycle redirects to the address in program space. In general, any instruction accessing data from program space takes 5 instruction cycles and therefore incurs a stall to ensure that the data is available.

Instructions operating in PSV address space are subject to RAW data dependencies and consequent instruction stalls, just like any other instruction. In Example 2-6, the sequence of instructions would take 7 instruction cycles to execute. The PSV access via `W1` requires 5 instruction cycles, while an additional cycle is inserted to resolve the RAW data dependency caused by `W2`.

Example 2-6:

```
ADD W0,[W1],[W2++] ; W1=0x8000, PSVPAG=0xAA, DSRPAG=0x0200
MOV [W2],[W3]
```

2.11 DATA SPACE ARBITER STALLS

A CPU stall can also be a result of competition for Extended Data Space resources. When the Data Space Arbiter logic determines that the CPU cycle must be stalled to allow another bus master (like, DMA controller or USB module) access to data memory, instruction execution is suspended until the higher priority bus master completes the data access.

2.12 REGISTER MAP

A summary of the registers associated with the dsPIC33E/PIC24E CPU is provided in Table 2-8.

Table 2-8: dsPIC33E/PIC24E CPU Register Map

Name	Bit 15	Bit 14	Bit 13	Bit 12	Bit 11	Bit 10	Bit 9	Bit 8	Bit 7	Bit 6	Bit 5	Bit 4	Bit 3	Bit 2	Bit 1	Bit 0	Reset State	
W0	W0 (WREG)																0000 0000 0000 0000	
W1	W1																0000 0000 0000 0000	
W2	W2																0000 0000 0000 0000	
W3	W3																0000 0000 0000 0000	
W4	W4																0000 0000 0000 0000	
W5	W5																0000 0000 0000 0000	
W6	W6																0000 0000 0000 0000	
W7	W7																0000 0000 0000 0000	
W8	W8																0000 0000 0000 0000	
W9	W9																0000 0000 0000 0000	
W10	W10																0000 0000 0000 0000	
W11	W11																0000 0000 0000 0000	
W12	W12																0000 0000 0000 0000	
W13	W13																0000 0000 0000 0000	
W14	W14																0000 0000 0000 0000	
W15	W15																0000 0000 0000 0000	
SPLIM	SPLIM																0000 0000 0000 0000	
ACCAL	ACCAL																0000 0000 0000 0000	
ACCAH	ACCAH																0000 0000 0000 0000	
ACCAU	Sign-extension of ACCA<39>								ACCAU								0000 0000 0000 0000	
ACCBL	ACCBL																0000 0000 0000 0000	
ACCBH	ACCBH																0000 0000 0000 0000	
ACCBU	Sign-extension of ACCB<39>								ACCBU								0000 0000 0000 0000	
PCL	PCL																0000 0000 0000 0000	
PCH	—	—	—	—	—	—	—	—	—	PCH							0	0000 0000 0000 0000
DSRPAG	—	—	—	—	—	—	DSRPAG									0001	0000 0000 0000 0001	
DSWPAG	—	—	—	—	—	—	DSWPAG									0001	0000 0000 0000 0001	
RCOUNT	RCOUNT																xxxx xxxx xxxx xxxx	
DCOUNT	DCOUNT																xxxx xxxx xxxx xxxx	
DOSTARTL	DOSTARTL															0	xxxx xxxx xxxx xxx0	
DOSTARTH	—	—	—	—	—	—	—	—	—	DOSTARTH							00xx	0000 0000 00xx xxxx
DOENDL	DOENDL															0	xxxx xxxx xxxx xxx0	

Legend: x = unknown value on Reset, — = unimplemented, read as '0'. Reset values are shown in hexadecimal.

Note: Refer to the device data sheet for specific Core Register Map details.

Table 2-8: dsPIC33E/PIC24E CPU Register Map (Continued)

Name	Bit 15	Bit 14	Bit 13	Bit 12	Bit 11	Bit 10	Bit 9	Bit 8	Bit 7	Bit 6	Bit 5	Bit 4	Bit 3	Bit 2	Bit 1	Bit 0	Reset State
DOENDH	—	—	—	—	—	—	—	—	—	DOENDH							0000 0000 00xx xxxx
SR	OA	OB	SA	SB	OAB	SAB	DA	DC	IPL2	IPL1	IPL0	RA	N	OV	Z	C	0000 0000 0000 0000
CORCON	—	—	US<1:0>		EDT	DL<2:0>			SATA	SATB	SATDW	ACCSAT	IPL3	SFA	RND	IF	0000 0000 0010 0000
MODCON	XMODEN	YMODEN	—	—	BWM<3:0>				YWM<3:0>			XWM<3:0>				0000 0000 0000 0000	
XMODSRT	XMODSRT<15:0>															0	xxxx xxxx xxxx xxx0
XMODEND	XMODEND<15:0>															1	xxxx xxxx xxxx xxx1
YMODSRT	YMODSRT<15:0>															0	xxxx xxxx xxxx xxx0
YMODEND	YMODEND<15:0>															1	xxxx xxxx xxxx xxx1
XBREV	BREN	XBREV<14:0>															xxxx xxxx xxxx xxxx
DISICNT	—	—	DISICNT<13:0>														0000 0000 0000 0000
TBLPAG	—	—	—	—	—	—	—	—	TBLPAG<7:0>								0000 0000 0000 0000
MSTRPR	MSTRPR<15:0>																0000 0000 0000 0000

Legend: x = unknown value on Reset, — = unimplemented, read as '0'. Reset values are shown in hexadecimal.

Note: Refer to the device data sheet for specific Core Register Map details.

2.13 RELATED APPLICATION NOTES

This section lists application notes that are related to this section of the manual. These application notes may not be written specifically for the dsPIC33E/PIC24E Product Family, but the concepts are pertinent and could be used with modification and possible limitations. The current application notes related to the dsPIC33E/PIC24E CPU are:

Title	Application Note #
No related application notes at this time.	

Note: Please visit the Microchip web site (www.microchip.com) for additional Application Notes and code examples for the dsPIC33E/PIC24E family of devices.

2.14 REVISION HISTORY

Revision A (November 2008)

This is the initial release of this document.

Revision B (May 2010)

This revision includes the following changes:

- Updated the document to include references to PIC24E devices
- Updated the titles of the following sections to indicate content applies only to dsPIC33E devices:
 - 2.1.5 “**DSP Engine and Instructions (dsPIC33E Devices Only)**”
 - 2.6.1 “**Data Accumulators (dsPIC33E Devices Only)**”
 - 2.6.2.1 “**DSP Multiply Instructions (dsPIC33E Devices Only)**”
 - 2.6.4 “**Round Logic (dsPIC33E Devices Only)**”
 - 2.6.5 “**Barrel Shifter (dsPIC33E Devices Only)**”
 - 2.6.6 “**DSP Engine Mode Selection (dsPIC33E Devices Only)**”
 - 2.6.7 “**DSP Engine Trap Events (dsPIC33E Devices Only)**”
 - 2.9.2 “**DO Loop Construct (dsPIC33E Devices Only)**”
- Added Note 1 to the Programmer’s Model Register Descriptions in Table 2-1
- Updated the Programmer’s Model in Figure 2-2
- Added a new sentence on additional causes of a stack error trap to the first shaded note in **2.3.3 “Stack Pointer Overflow”**
- Added a new Note 1 and Note 2 to the CPU Status Register (see Register 2-1); existing Note 1 and Note 2 were renumbered as Note 3 and Note 4
- Added a new Note 2 to the Core Control Register (see Register 2-2); the existing Note 2 was renumbered as Note 3
- Removed Note 2 and added three rows to the MCU Instructions that Utilize the Multiplier (see Table 2-4)
- Updated the second `MOV.D` instruction in Figure 2-13
- Updated the third instruction in Figure 2-15
- Updated the fourth instruction in Figure 2-16
- Updated the second and third instructions in Figure 2-18
- Updated the second and third instructions in Figure 2-19
- Updated the second shaded note in **2.9.1.1 “REPEAT Operation”**
- Updated the last sentence in the first paragraph of **2.9.2 “DO Loop Construct (dsPIC33E Devices Only)”**
- Updated the `MOV` instruction in Figure 2-21
- Updated the first sentence in the first paragraph of **2.10.2.4 “Instruction Stalls and Program Space Visibility (PSV)”**
- Updated the last paragraph of **2.10.2.4 “Instruction Stalls and Program Space Visibility (PSV)”**
- Changed the ranges for the available bits in the `DOSTARTH`, `DOENDH`, and `MSTRPR` SFRs in the CPU Register Map (see Table 2-8)
- Additional minor formatting updates were incorporated throughout the document

NOTES:

Note the following details of the code protection feature on Microchip devices:

- Microchip products meet the specification contained in their particular Microchip Data Sheet.
- Microchip believes that its family of products is one of the most secure families of its kind on the market today, when used in the intended manner and under normal conditions.
- There are dishonest and possibly illegal methods used to breach the code protection feature. All of these methods, to our knowledge, require using the Microchip products in a manner outside the operating specifications contained in Microchip's Data Sheets. Most likely, the person doing so is engaged in theft of intellectual property.
- Microchip is willing to work with the customer who is concerned about the integrity of their code.
- Neither Microchip nor any other semiconductor manufacturer can guarantee the security of their code. Code protection does not mean that we are guaranteeing the product as “unbreakable.”

Code protection is constantly evolving. We at Microchip are committed to continuously improving the code protection features of our products. Attempts to break Microchip's code protection feature may be a violation of the Digital Millennium Copyright Act. If such acts allow unauthorized access to your software or other copyrighted work, you may have a right to sue for relief under that Act.

Information contained in this publication regarding device applications and the like is provided only for your convenience and may be superseded by updates. It is your responsibility to ensure that your application meets with your specifications. MICROCHIP MAKES NO REPRESENTATIONS OR WARRANTIES OF ANY KIND WHETHER EXPRESS OR IMPLIED, WRITTEN OR ORAL, STATUTORY OR OTHERWISE, RELATED TO THE INFORMATION, INCLUDING BUT NOT LIMITED TO ITS CONDITION, QUALITY, PERFORMANCE, MERCHANTABILITY OR FITNESS FOR PURPOSE. Microchip disclaims all liability arising from this information and its use. Use of Microchip devices in life support and/or safety applications is entirely at the buyer's risk, and the buyer agrees to defend, indemnify and hold harmless Microchip from any and all damages, claims, suits, or expenses resulting from such use. No licenses are conveyed, implicitly or otherwise, under any Microchip intellectual property rights.

Trademarks

The Microchip name and logo, the Microchip logo, dsPIC, KEELOQ, KEELOQ logo, MPLAB, PIC, PICmicro, PICSTART, PIC³² logo, rPIC and UNI/O are registered trademarks of Microchip Technology Incorporated in the U.S.A. and other countries.

FilterLab, Hampshire, HI-TECH C, Linear Active Thermistor, MXDEV, MXLAB, SEEVAL and The Embedded Control Solutions Company are registered trademarks of Microchip Technology Incorporated in the U.S.A.

Analog-for-the-Digital Age, Application Maestro, CodeGuard, dsPICDEM, dsPICDEM.net, dsPICworks, dsSPEAK, ECAN, ECONOMONITOR, FanSense, HI-TIDE, In-Circuit Serial Programming, ICSP, Mindi, MiWi, MPASM, MPLAB Certified logo, MPLIB, MPLINK, mTouch, Octopus, Omniscient Code Generation, PICC, PICC-18, PICDEM, PICDEM.net, PICkit, PICTail, REAL ICE, rLAB, Select Mode, Total Endurance, TSHARC, UniWinDriver, WiperLock and ZENA are trademarks of Microchip Technology Incorporated in the U.S.A. and other countries.

SQTP is a service mark of Microchip Technology Incorporated in the U.S.A.

All other trademarks mentioned herein are property of their respective companies.

© 2010, Microchip Technology Incorporated, Printed in the U.S.A., All Rights Reserved.

 Printed on recycled paper.

ISBN: 978-1-60932-171-0

Microchip received ISO/TS-16949:2002 certification for its worldwide headquarters, design and wafer fabrication facilities in Chandler and Tempe, Arizona; Gresham, Oregon and design centers in California and India. The Company's quality system processes and procedures are for its PIC[®] MCUs and dsPIC[®] DSCs, KEELOQ[®] code hopping devices, Serial EEPROMs, microperipherals, nonvolatile memory and analog products. In addition, Microchip's quality system for the design and manufacture of development systems is ISO 9001:2000 certified.

**QUALITY MANAGEMENT SYSTEM
CERTIFIED BY DNV
== ISO/TS 16949:2002 ==**



WORLDWIDE SALES AND SERVICE

AMERICAS

Corporate Office
2355 West Chandler Blvd.
Chandler, AZ 85224-6199
Tel: 480-792-7200
Fax: 480-792-7277
Technical Support:
<http://support.microchip.com>
Web Address:
www.microchip.com

Atlanta
Duluth, GA
Tel: 678-957-9614
Fax: 678-957-1455

Boston
Westborough, MA
Tel: 774-760-0087
Fax: 774-760-0088

Chicago
Itasca, IL
Tel: 630-285-0071
Fax: 630-285-0075

Cleveland
Independence, OH
Tel: 216-447-0464
Fax: 216-447-0643

Dallas
Addison, TX
Tel: 972-818-7423
Fax: 972-818-2924

Detroit
Farmington Hills, MI
Tel: 248-538-2250
Fax: 248-538-2260

Kokomo
Kokomo, IN
Tel: 765-864-8360
Fax: 765-864-8387

Los Angeles
Mission Viejo, CA
Tel: 949-462-9523
Fax: 949-462-9608

Santa Clara
Santa Clara, CA
Tel: 408-961-6444
Fax: 408-961-6445

Toronto
Mississauga, Ontario,
Canada
Tel: 905-673-0699
Fax: 905-673-6509

ASIA/PACIFIC

Asia Pacific Office
Suites 3707-14, 37th Floor
Tower 6, The Gateway
Harbour City, Kowloon
Hong Kong
Tel: 852-2401-1200
Fax: 852-2401-3431

Australia - Sydney
Tel: 61-2-9868-6733
Fax: 61-2-9868-6755

China - Beijing
Tel: 86-10-8528-2100
Fax: 86-10-8528-2104

China - Chengdu
Tel: 86-28-8665-5511
Fax: 86-28-8665-7889

China - Chongqing
Tel: 86-23-8980-9588
Fax: 86-23-8980-9500

China - Hong Kong SAR
Tel: 852-2401-1200
Fax: 852-2401-3431

China - Nanjing
Tel: 86-25-8473-2460
Fax: 86-25-8473-2470

China - Qingdao
Tel: 86-532-8502-7355
Fax: 86-532-8502-7205

China - Shanghai
Tel: 86-21-5407-5533
Fax: 86-21-5407-5066

China - Shenyang
Tel: 86-24-2334-2829
Fax: 86-24-2334-2393

China - Shenzhen
Tel: 86-755-8203-2660
Fax: 86-755-8203-1760

China - Wuhan
Tel: 86-27-5980-5300
Fax: 86-27-5980-5118

China - Xian
Tel: 86-29-8833-7252
Fax: 86-29-8833-7256

China - Xiamen
Tel: 86-592-2388138
Fax: 86-592-2388130

China - Zhuhai
Tel: 86-756-3210040
Fax: 86-756-3210049

ASIA/PACIFIC

India - Bangalore
Tel: 91-80-3090-4444
Fax: 91-80-3090-4123

India - New Delhi
Tel: 91-11-4160-8631
Fax: 91-11-4160-8632

India - Pune
Tel: 91-20-2566-1512
Fax: 91-20-2566-1513

Japan - Yokohama
Tel: 81-45-471- 6166
Fax: 81-45-471-6122

Korea - Daegu
Tel: 82-53-744-4301
Fax: 82-53-744-4302

Korea - Seoul
Tel: 82-2-554-7200
Fax: 82-2-558-5932 or
82-2-558-5934

Malaysia - Kuala Lumpur
Tel: 60-3-6201-9857
Fax: 60-3-6201-9859

Malaysia - Penang
Tel: 60-4-227-8870
Fax: 60-4-227-4068

Philippines - Manila
Tel: 63-2-634-9065
Fax: 63-2-634-9069

Singapore
Tel: 65-6334-8870
Fax: 65-6334-8850

Taiwan - Hsin Chu
Tel: 886-3-6578-300
Fax: 886-3-6578-370

Taiwan - Kaohsiung
Tel: 886-7-536-4818
Fax: 886-7-536-4803

Taiwan - Taipei
Tel: 886-2-2500-6610
Fax: 886-2-2508-0102

Thailand - Bangkok
Tel: 66-2-694-1351
Fax: 66-2-694-1350

EUROPE

Austria - Wels
Tel: 43-7242-2244-39
Fax: 43-7242-2244-393

Denmark - Copenhagen
Tel: 45-4450-2828
Fax: 45-4485-2829

France - Paris
Tel: 33-1-69-53-63-20
Fax: 33-1-69-30-90-79

Germany - Munich
Tel: 49-89-627-144-0
Fax: 49-89-627-144-44

Italy - Milan
Tel: 39-0331-742611
Fax: 39-0331-466781

Netherlands - Drunen
Tel: 31-416-690399
Fax: 31-416-690340

Spain - Madrid
Tel: 34-91-708-08-90
Fax: 34-91-708-08-91

UK - Wokingham
Tel: 44-118-921-5869
Fax: 44-118-921-5820