

---



---

## Section 16. Analog-to-Digital Converter (ADC)

---



---

### HIGHLIGHTS

This section of the manual contains the following major topics:

16.1	Introduction .....	16-2
16.2	Control Registers .....	16-4
16.3	A/D Terminology and Conversion Sequence .....	16-14
16.4	ADC Module Configuration .....	16-16
16.5	Selecting the Voltage Reference Source .....	16-16
16.6	Selecting the A/D Conversion Clock .....	16-17
16.7	Selecting Analog Inputs for Sampling .....	16-18
16.8	Enabling the Module .....	16-20
16.9	Specifying Sample/Conversion Control .....	16-20
16.10	How to Start Sampling .....	16-21
16.11	How to Stop Sampling and Start Conversions .....	16-22
16.12	Controlling Sample/Conversion Operation .....	16-32
16.13	Specifying Conversion Results Buffering .....	16-33
16.14	Conversion Sequence Examples .....	16-37
16.15	A/D Sampling Requirements .....	16-49
16.16	Reading the ADC Result Buffer .....	16-50
16.17	Transfer Function (10-bit Mode) .....	16-52
16.18	Transfer Function (12-bit Mode) .....	16-53
16.19	ADC Accuracy/Error .....	16-54
16.20	Connection Considerations .....	16-54
16.21	Code Examples .....	16-54
16.22	Operation During Sleep and Idle Modes .....	16-61
16.23	Effects of a Reset .....	16-62
16.24	Special Function Registers Associated with the ADC .....	16-62
16.25	Design Tips .....	16-64
16.26	Related Application Notes .....	16-65
16.27	Revision History .....	16-66

## 16.1 INTRODUCTION

The PIC24H family devices have up to 32 A/D input channels. These devices also have up to two ADC modules (ADC<sub>x</sub>, where x = 1 or 2), each with its own set of Special Function Registers (SFRs).

The 10-bit or 12-bit Operation Mode (AD12B) bit in the ADC<sub>x</sub> Control 1 (AD<sub>x</sub>CON1) register allows each of the ADC modules to be configured by the user application as either a 10-bit, 4 Sample/Hold (S/H) ADC (default configuration) or a 12-bit, 1 Sample/Hold ADC.

**Note:** The ADC module needs to be disabled before the AD12B bit is modified.

The 10-bit ADC configuration (AD12B = 0) has the following key features:

- Successive Approximation (SAR) conversion
- Conversion speeds of up to 1.1 Msps
- Up to 32 analog input pins
- External voltage reference input pins
- Simultaneous sampling of up to four analog input pins
- Automatic Channel Scan mode
- Selectable conversion trigger source
- Selectable Buffer Fill modes
- DMA support, including Peripheral Indirect Addressing
- Four result alignment options (signed/unsigned, fractional/integer)
- Operation during CPU Sleep and Idle modes

Depending on the particular device pinout, the ADC can have up to 32 analog input pins, designated AN0 through AN31. In addition, there are two analog input pins for external voltage reference connections. These voltage reference inputs can be shared with other analog input pins. The actual number of analog input pins and external voltage reference input configuration will depend on the specific device. Refer to the device data sheet for further details.

The analog inputs are multiplexed to four Sample/Hold amplifiers, designated CH0-CH3. One, two, or four of the Sample/Hold amplifiers can be enabled for acquiring input data. The analog input multiplexers can be switched between two sets of analog inputs during conversions. Unipolar differential conversions are possible on all channels using certain input pins (see Figure 16-1).

An Analog Input Scan mode can be enabled for the CH0 Sample/Hold Amplifier. A Control register specifies which analog input channels are included in the scanning sequence.

The ADC is connected to a single-word result buffer. However, multiple conversion results can be stored in a DMA RAM buffer with no CPU overhead. Each conversion result is converted to one of four 16-bit output formats when it is read from the buffer.

The 12-bit ADC configuration (AD12B = 1) supports all the above features, except:

- In the 12-bit configuration, conversion speeds of up to 500 kcps are supported
- There is only one Sample/Hold amplifier in the 12-bit configuration, so simultaneous sampling of multiple channels is not supported.

Figure 16-1: ADC Block Diagram

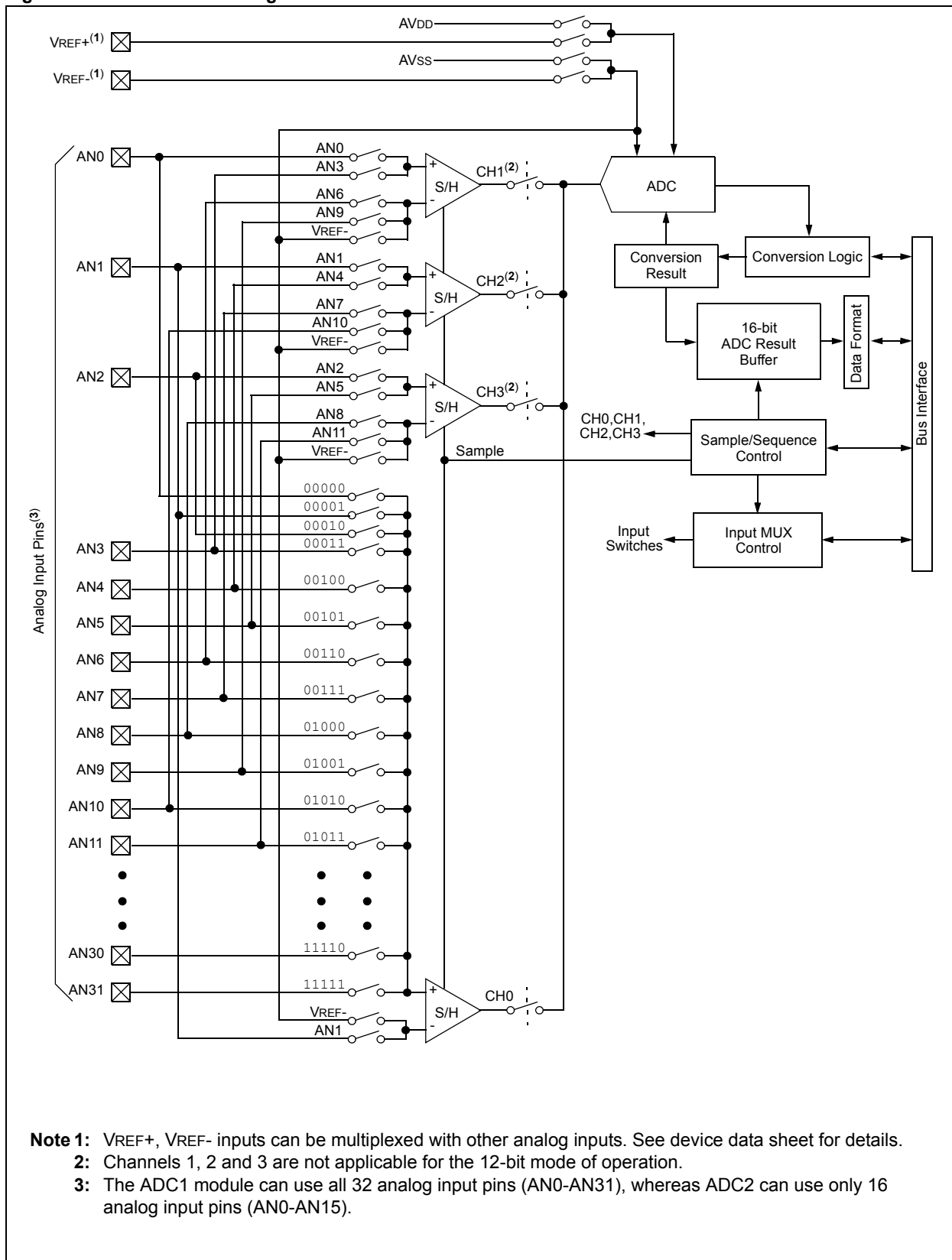

## 16.2 CONTROL REGISTERS

The ADC module has ten Control and Status registers. These registers are:

- ADxCON1: ADCx Control Register 1(1)
- ADxCON2: ADCx Control Register 2(1)
- ADxCON3: ADCx Control Register 3(1)
- ADxCON4: ADCx Control Register 4(1)
- ADxCHS123: ADCx Input Channel 1, 2, 3 Select Register(1)
- ADxCHS0: ADCx Input Channel 0 Select Register
- AD1CSSH: ADC1 Input Scan Select Register High
- ADxCSSL: ADCx Input Scan Select Register Low
- AD1PCFGH: ADC1 Port Configuration Register High
- ADxPCFGL: ADCx Port Configuration Register Low

The ADxCON1, ADxCON2 and ADxCON3 registers control the operation of the ADC module. The ADxCON4 register sets up the number of conversion results stored in a DMA buffer for each analog input in the Scatter/Gather mode. The ADxCHS123 and ADxCHS0 registers select the input pins to be connected to the Sample/Hold amplifiers. The ADxPCFGH/L registers configure the analog input pins as analog inputs or as digital I/O. The ADCSSH/L registers select inputs to be sequentially scanned.

# Section 16. Analog-to-Digital Converter (ADC)

**Register 16-1: ADxCON1: ADCx Control Register 1<sup>(1)</sup>**

R/W-0	U-0	R/W-0	R/W-0	U-0	R/W-0	R/W-0	R/W-0
ADON	—	ADSIDL	ADDMABM	—	AD12B	FORM<1:0>	
bit 15						bit 8	
R/W-0	R/W-0	R/W-0	U-0	R/W-0	R/W-0	R/W-0	R/C-0
SSRC<2:0>			—	SIMSAM	ASAM	SAMP	HC, HS HC, HS
bit 7						bit 0	

<b>Legend:</b>	HC = Cleared by hardware	HS = Set by hardware
R = Readable bit	W = Writable bit	U = Unimplemented bit, read as '0'
-n = Value at POR	'1' = Bit is set	'0' = Bit is cleared
		x = Bit is unknown

- bit 15      **ADON:** ADC Operating Mode bit  
             1 = ADC module is operating  
             0 = ADC is off
- bit 14      **Unimplemented:** Read as '0'
- bit 13      **ADSIDL:** Stop in Idle Mode bit  
             1 = Discontinue module operation when device enters Idle mode  
             0 = Continue module operation in Idle mode
- bit 12      **ADDMABM:** DMA Buffer Build Mode bit  
             1 = DMA buffers are written in the order of conversion. The module provides an address to the DMA channel that is the same as the address used for the non-DMA stand-alone buffer.  
             0 = DMA buffers are written in Scatter/Gather mode. The module provides a Scatter/Gather address to the DMA channel, based on the index of the analog input and the size of the DMA buffer.
- bit 11      **Unimplemented:** Read as '0'
- bit 10      **AD12B:** 10-bit or 12-bit Operation Mode bit  
             1 = 12-bit, 1-channel ADC operation  
             0 = 10-bit, 4-channel ADC operation
- bit 9-8     **FORM<1:0>:** Data Output Format bits  
             For 10-bit operation:  
             11 = Reserved  
             10 = Reserved  
             01 = Signed integer (DOUT = ssss sssd dddd dddd, where s = .NOT.d<9>)  
             00 = Integer (DOUT = 0000 00dd dddd dddd)  
             For 12-bit operation:  
             11 = Signed fractional (DOUT = sddd dddd dddd 0000, where s = .NOT.d<11>)  
             10 = Fractional (DOUT = dddd dddd dddd 0000)  
             01 = Signed Integer (DOUT = ssss sddd dddd dddd, where s = .NOT.d<11>)  
             00 = Integer (DOUT = 0000 dddd dddd dddd)
- bit 7-5     **SSRC<2:0>:** Sample Clock Source Select bits  
             111 = Internal counter ends sampling and starts conversion (auto-convert)  
             110 = Reserved  
             101 = Reserved  
             100 = Reserved  
             011 = Reserved  
             010 = GP timer (Timer3 for ADC1, Timer5 for ADC2) compare ends sampling and starts conversion  
             001 = Active transition on INTx pin ends sampling and starts conversion  
             000 = Clearing sample bit ends sampling and starts conversion
- bit 4        **Unimplemented:** Read as '0'

**Note 1:** The 'x' in ADxCON1 and ADCx refers to ADC 1 or ADC 2.

# PIC24H Family Reference Manual

---

## Register 16-1: ADxCON1: ADCx Control Register 1<sup>(1)</sup> (Continued)

- bit 3      **SIMSAM**: Simultaneous Sample Select bit (only applicable when CHPS<1:0> = 01 or 1x)  
            **When AD12B = 1, SIMSAM is: U-0, Unimplemented, Read as '0'**  
            1 = Samples CH0, CH1, CH2, CH3 simultaneously (when CHPS<1:0> = 1x); or  
                Samples CH0 and CH1 simultaneously (when CHPS<1:0> = 01)  
            0 = Samples multiple channels individually in sequence
- bit 2      **ASAM**: ADC Sample Auto-Start bit  
            1 = Sampling begins immediately after last conversion. SAMP bit is auto-set.  
            0 = Sampling begins when SAMP bit is set
- bit 1      **SAMP**: ADC Sample Enable bit  
            1 = ADC Sample/Hold amplifiers are sampling  
            0 = ADC Sample/Hold amplifiers are holding  
            If ASAM = 0, software can write '1' to begin sampling. Automatically set by hardware if ASAM = 1.  
            If SSRC = 000, software can write '0' to end sampling and start conversion. If SSRC ≠ 000,  
                automatically cleared by hardware to end sampling and start conversion.
- bit 0      **DONE**: ADC Conversion Status bit  
            1 = ADC conversion cycle is completed.  
            0 = ADC conversion not started or in progress  
            Automatically set by hardware when A/D conversion is complete. Software can write '0' to clear DONE  
                status (software not allowed to write '1'). Clearing this bit does NOT affect any operation in  
                progress. Automatically cleared by hardware at start of a new conversion.

**Note 1:** The 'x' in ADxCON1 and ADCx refers to ADC 1 or ADC 2.

**Register 16-2: ADxCON2: ADCx Control Register 2<sup>(1)</sup>**

R/W-0	R/W-0	R/W-0	U-0	U-0	R/W-0	R/W-0	R/W-0	
VCFG<2:0>			—	—	CSCNA	CHPS<1:0>		
bit 15								bit 8
R-0	U-0	R/W-0	R/W-0	R/W-0	R/W-0	R/W-0	R/W-0	
BUFS	—	SMPI<3:0>				BUFM	ALTS	
bit 7								bit 0

<b>Legend:</b>			
R = Readable bit	W = Writable bit	U = Unimplemented bit, read as '0'	
-n = Value at POR	'1' = Bit is set	'0' = Bit is cleared	x = Bit is unknown

bit 15-13     **VCFG<2:0>**: Converter Voltage Reference Configuration bits

	VREFH	VREFL
000	AVDD	Avss
001	External VREF+	Avss
010	AVDD	External VREF-
011	External VREF+	External VREF-
1xx	AVDD	Avss

bit 12-11     **Unimplemented**: Read as '0'

bit 10     **CSCNA**: Input Scan Select bit

- 1 = Scan inputs for CH0+ during Sample A bit
- 0 = Do not scan inputs

bit 9-8     **CHPS<1:0>**: Channel Select bits

- When AD12B = 1, CHPS<1:0> is: U-0, Unimplemented, Read as '0'
- 1x = Converts CH0, CH1, CH2 and CH3
- 01 = Converts CH0 and CH1
- 00 = Converts CH0

bit 7     **BUFS**: Buffer Fill Status bit (only valid when BUFM = 1)

- 1 = ADC is currently filling the second half of the buffer. The user application should access data in the first half of the buffer
- 0 = ADC is currently filling the first half of the buffer. The user application should access data in the second half of the buffer.

bit 6     **Unimplemented**: Read as '0'

bit 5-2     **SMPI<3:0>**: Increment Rate for DMA Addresses bits

- 1111 = Increments the DMA address or generates interrupt after completion of every 16th sample/conversion operation
- 1110 = Increments the DMA address or generates interrupt after completion of every 15th sample/conversion operation
- ...
- 0001 = Increments the DMA address or generates interrupt after completion of every 2nd sample/conversion operation
- 0000 = Increments the DMA address or generates interrupt after completion of every sample/conversion operation

bit 1     **BUFM**: Buffer Fill Mode Select bit

- 1 = Starts buffer filling the first half of the buffer on the first interrupt and the second half of the buffer on next interrupt
- 0 = Always starts filling the buffer from the start address.

bit 0     **ALTS**: Alternate Input Sample Mode Select bit

- 1 = Uses channel input selects for Sample A on first sample and Sample B on next sample
- 0 = Always uses channel input selects for Sample A

**Note 1:** The 'x' in ADxCON2 and ADCx refers to ADC 1 or ADC 2.

# PIC24H Family Reference Manual

**Register 16-3: ADxCON3: ADCx Control Register 3<sup>(1)</sup>**

R/W-0	U-0	U-0	R/W-0	R/W-0	R/W-0	R/W-0	R/W-0
ADRC	—	—	SAMC<4:0>				
bit 15			bit 8				
R/W-0	R/W-0	R/W-0	R/W-0	R/W-0	R/W-0	R/W-0	R/W-0
ADCS<7:0>							
bit 7			bit 0				

**Legend:**

R = Readable bit	W = Writable bit	U = Unimplemented bit, read as '0'
-n = Value at POR	'1' = Bit is set	'0' = Bit is cleared
		x = Bit is unknown

- bit 15      **ADRC:** ADC Conversion Clock Source bit  
             1 = ADC Internal RC Clock  
             0 = Clock Derived From System Clock
- bit 14-13    **Unimplemented:** Read as '0'
- bit 12-8     **SAMC<4:0>:** Auto Sample Time bits  
             11111 = 31 TAD  
             •••  
             00001 = 1 TAD  
             00000 = 0 TAD
- bit 7-0      **ADCS<7:0>:** ADC Conversion Clock Select bits  
             11111111 =  $T_{CY} \cdot (ADCS<7:0> + 1) = 256 \cdot T_{CY} = TAD$   
             •••  
             00000010 =  $T_{CY} \cdot (ADCS<7:0> + 1) = 3 \cdot T_{CY} = TAD$   
             00000001 =  $T_{CY} \cdot (ADCS<7:0> + 1) = 2 \cdot T_{CY} = TAD$   
             00000000 =  $T_{CY} \cdot (ADCS<7:0> + 1) = 1 \cdot T_{CY} = TAD$

**Note 1:** The 'x' in ADxCON3 and ADCx refers to ADC 1 or ADC 2.



# Section 16. Analog-to-Digital Converter (ADC)

**Register 16-4: ADxCON4: ADCx Control Register 4<sup>(1)</sup>**

U-0	U-0	U-0	U-0	U-0	U-0	U-0	U-0
—	—	—	—	—	—	—	—
bit 15						bit 8	
U-0	U-0	U-0	U-0	U-0	R/W-0	R/W-0	R/W-0
—	—	—	—	—	DMABL<2:0>		
bit 7						bit 0	

**Legend:**

R = Readable bit                      W = Writable bit                      U = Unimplemented bit, read as '0'  
 -n = Value at POR                      '1' = Bit is set                      '0' = Bit is cleared                      x = Bit is unknown

bit 15-3                      **Unimplemented:** Read as '0'

bit 2-0                      **DMABL<2:0>:** Selects Number of DMA Buffer Locations per Analog Input bits

- 111 =Allocates 128 words of buffer to each analog input
- 110 =Allocates 64 words of buffer to each analog input
- 101 =Allocates 32 words of buffer to each analog input
- 100 =Allocates 16 words of buffer to each analog input
- 011 =Allocates 8 words of buffer to each analog input
- 010 =Allocates 4 words of buffer to each analog input
- 001 =Allocates 2 words of buffer to each analog input
- 000 =Allocates 1 word of buffer to each analog input

**Note 1:** The 'x' in ADxCON4 and ADCx refers to ADC 1 or ADC 2.

# PIC24H Family Reference Manual

**Register 16-5: ADxCHS123: ADCx Input Channel 1, 2, 3 Select Register<sup>(1)</sup>**

U-0	U-0	U-0	U-0	U-0	R/W-0	R/W-0	R/W-0
—	—	—	—	—	CH123NB<1:0>		CH123SB
bit 15							bit 8

U-0	U-0	U-0	U-0	U-0	R/W-0	R/W-0	R/W-0
—	—	—	—	—	CH123NA<1:0>		CH123SA
bit 7							bit 0

**Legend:**

R = Readable bit	W = Writable bit	U = Unimplemented bit, read as '0'
-n = Value at POR	'1' = Bit is set	'0' = Bit is cleared
		x = Bit is unknown

- bit 15-11     **Unimplemented:** Read as '0'
- bit 10-9     **CH123NB<1:0>:** Channel 1, 2, 3 Negative Input Select for Sample B bits  
 When AD12B = 1, CHxNB is: U-0, Unimplemented, Read as '0'  
 11 = CH1 negative input is AN9, CH2 negative input is AN10, CH3 negative input is AN11  
 10 = CH1 negative input is AN6, CH2 negative input is AN7, CH3 negative input is AN8  
 0x = CH1, CH2, CH3 negative input is VREFL
- bit 8         **CH123SB:** Channel 1, 2, 3 Positive Input Select for Sample B bit  
 When AD12B = 1, CHxSA is: U-0, Unimplemented, Read as '0'  
 1 = CH1 positive input is AN3, CH2 positive input is AN4, CH3 positive input is AN5  
 0 = CH1 positive input is AN0, CH2 positive input is AN1, CH3 positive input is AN2
- bit 7-3     **Unimplemented:** Read as '0'
- bit 2-1     **CH123NA<1:0>:** Channel 1, 2, 3 Negative Input Select for Sample A bits  
 When AD12B = 1, CHxNA is: U-0, Unimplemented, Read as '0'  
 11 = CH1 negative input is AN9, CH2 negative input is AN10, CH3 negative input is AN11  
 10 = CH1 negative input is AN6, CH2 negative input is AN7, CH3 negative input is AN8  
 0x = CH1, CH2, CH3 negative input is VREFL
- bit 0         **CH123SA:** Channel 1, 2, 3 Positive Input Select for Sample A bit  
 When AD12B = 1, CHxSA is: U-0, Unimplemented, Read as '0'  
 1 = CH1 positive input is AN3, CH2 positive input is AN4, CH3 positive input is AN5  
 0 = CH1 positive input is AN0, CH2 positive input is AN1, CH3 positive input is AN2

**Note 1:** The 'x' in ADxCHS123 and ADCx refers to ADC 1 or ADC 2.

## Section 16. Analog-to-Digital Converter (ADC)

**Register 16-6: ADxCHS0: ADCx Input Channel 0 Select Register**

R/W-0	U-0	U-0	R/W-0	R/W-0	R/W-0	R/W-0	R/W-0	
CH0NB	—	—	CH0SB<4:0>					
bit 15								bit 8
R/W-0	U-0	U-0	R/W-0	R/W-0	R/W-0	R/W-0	R/W-0	
CH0NA	—	—	CH0SA<4:0>					
bit 7								bit 0

<b>Legend:</b>			
R = Readable bit	W = Writable bit	U = Unimplemented bit, read as '0'	
-n = Value at POR	'1' = Bit is set	'0' = Bit is cleared	x = Bit is unknown

- bit 15      **CH0NB:** Channel 0 Negative Input Select for Sample B bit  
Same definition as bit 7.
- bit 14-13    **Unimplemented:** Read as '0'
- bit 12-8     **CH0SB<4:0>:** Channel 0 Positive Input Select for Sample B bits<sup>(1, 2)</sup>  
Same definition as bit<4:0>.
- bit 7        **CH0NA:** Channel 0 Negative Input Select for Sample A bit  
1 = Channel 0 negative input is AN1  
0 = Channel 0 negative input is VREFL
- bit 6-5     **Unimplemented:** Read as '0'
- bit 4-0     **CH0SA<4:0>:** Channel 0 Positive Input Select for Sample A bits<sup>(1, 2)</sup>  
11111 = Channel 0 positive input is AN31  
11110 = Channel 0 positive input is AN30  
...  
00010 = Channel 0 positive input is AN2  
00001 = Channel 0 positive input is AN1  
00000 = Channel 0 positive input is AN0

**Note 1:** The AN16 – AN31 pins are not available for ADC 2.  
**2:** The 'x' in ADxCHS0 and ADCx refers to ADC 1 or ADC 2

# PIC24H Family Reference Manual

## Register 16-7: AD1CSSH: ADC1 Input Scan Select Register High

R/W-0	R/W-0	R/W-0	R/W-0	R/W-0	R/W-0	R/W-0	R/W-0
CSS31	CSS30	CSS29	CSS28	CSS27	CSS26	CSS25	CSS24
bit 15							bit 8

R/W-0	R/W-0	R/W-0	R/W-0	R/W-0	R/W-0	R/W-0	R/W-0
CSS23	CSS22	CSS21	CSS20	CSS19	CSS18	CSS17	CSS16
bit 7							bit 0

### Legend:

R = Readable bit                      W = Writable bit                      U = Unimplemented bit, read as '0'  
 -n = Value at POR                      '1' = Bit is set                      '0' = Bit is cleared                      x = Bit is unknown

bit 15-0                      **CSS<31:16>**: ADC Input Scan Selection bits<sup>(1, 2)</sup>

1 = Select ANx for input scan

0 = Skip ANx for input scan

**Note 1:** On devices with less than 32 analog inputs, all ADxCSSL bits can be selected by user. However, inputs selected for scan without a corresponding input on device convert VREF-.

**2:** ADC 2 only supports analog inputs AN0-AN15; therefore, no ADC 2 Input Scan Select register exists.

## Register 16-8: ADxCSSL: ADCx Input Scan Select Register Low

R/W-0	R/W-0	R/W-0	R/W-0	R/W-0	R/W-0	R/W-0	R/W-0
CSS15	CSS14	CSS13	CSS12	CSS11	CSS10	CSS9	CSS8
bit 15							bit 8

R/W-0	R/W-0	R/W-0	R/W-0	R/W-0	R/W-0	R/W-0	R/W-0
CSS7	CSS6	CSS5	CSS4	CSS3	CSS2	CSS1	CSS0
bit 7							bit 0

### Legend:

R = Readable bit                      W = Writable bit                      U = Unimplemented bit, read as '0'  
 -n = Value at POR                      '1' = Bit is set                      '0' = Bit is cleared                      x = Bit is unknown

bit 15-0                      **CSS<15:0>**: ADC Input Scan Selection bits<sup>(1, 2)</sup>

1 = Select ANx for input scan

0 = Skip ANx for input scan

**Note 1:** On devices with less than 16 analog inputs, all ADxCSSL bits can be selected by the user. However, inputs selected for scan without a corresponding input on device convert VREF-.

**2:** The 'x' in ADxCSSL and ADCx refers to ADC 1 or ADC 2.

# Section 16. Analog-to-Digital Converter (ADC)

**Register 16-9: AD1PCFGH: ADC1 Port Configuration Register High**

R/W-0	R/W-0	R/W-0	R/W-0	R/W-0	R/W-0	R/W-0	R/W-0
PCFG31	PCFG30	PCFG29	PCFG28	PCFG27	PCFG26	PCFG25	PCFG24
bit 15							bit 8

R/W-0	R/W-0	R/W-0	R/W-0	R/W-0	R/W-0	R/W-0	R/W-0
PCFG23	PCFG22	PCFG21	PCFG20	PCFG19	PCFG18	PCFG17	PCFG16
bit 7							bit 0

**Legend:**  
 R = Readable bit                      W = Writable bit                      U = Unimplemented bit, read as '0'  
 -n = Value at POR                      '1' = Bit is set                      '0' = Bit is cleared                      x = Bit is unknown

bit 15-0                      **PCFG<31:16>**: ADC Port Configuration Control bits<sup>(1, 2)</sup>  
                                     1 = Port pin in Digital mode, port read input enabled, ADC input multiplexor connected to AVss  
                                     0 = Port pin in Analog mode, port read input disabled, ADC samples pin voltage

**Note 1:** On devices with less than 32 analog inputs, all PCFG bits are R/W by user. However, PCFG bits are ignored on ports without a corresponding input on device.  
**2:** ADC2 only supports analog inputs AN0-AN15; therefore, no ADC2 Port Configuration register exists.

**Register 16-10: ADxPCFGL: ADCx Port Configuration Register Low**

R/W-0	R/W-0	R/W-0	R/W-0	R/W-0	R/W-0	R/W-0	R/W-0
PCFG15	PCFG14	PCFG13	PCFG12	PCFG11	PCFG10	PCFG9	PCFG8
bit 15							bit 8

R/W-0	R/W-0	R/W-0	R/W-0	R/W-0	R/W-0	R/W-0	R/W-0
PCFG7	PCFG6	PCFG5	PCFG4	PCFG3	PCFG2	PCFG1	PCFG0
bit 7							bit 0

**Legend:**  
 R = Readable bit                      W = Writable bit                      U = Unimplemented bit, read as '0'  
 -n = Value at POR                      '1' = Bit is set                      '0' = Bit is cleared                      x = Bit is unknown

bit 15-0                      **PCFG<15:0>**: ADC Port Configuration Control bits<sup>(1, 2, 3)</sup>  
                                     1 = Port pin in Digital mode, port read input enabled, ADC input multiplexor connected to AVss  
                                     0 = Port pin in Analog mode, port read input disabled, ADC samples pin voltage

**Note 1:** On devices with less than 16 analog inputs, all PCFG bits are R/W by user. However, PCFG bits are ignored on ports without a corresponding input on device.  
**2:** On devices with two analog-to-digital modules, both AD1PCFGL and AD2PCFGL affect the configuration of port pins multiplexed with AN0-AN15.  
**3:** The 'x' in ADxPCFGL and ADx refers to ADC 1 or ADC 2

## 16.3 A/D TERMINOLOGY AND CONVERSION SEQUENCE

Figure 16-2 shows a basic conversion sequence and the terms that are used. A sampling of the analog input pin voltage is performed by Sample/Hold amplifiers (also called Sample/Hold channels). The 10-bit ADC configuration can use up to four Sample/Hold channels, designated CH0-CH3, whereas the 12-bit ADC configuration can use only one Sample/Hold channel, CH0. The Sample/Hold channels are connected to the analog input pins via the analog input multiplexer. The analog input multiplexer is controlled by the ADxCHS123 and ADxCHS0 registers. There are two sets of multiplexer control bits in the ADC channel select registers that function identically. These two sets of control bits allow two different analog input multiplexer configurations to be programmed (called MUX A and MUX B). The ADC can optionally switch between the MUX A and MUX B configurations between conversions. The ADC can also optionally scan through a series of analog inputs.

Sample time is the time that the ADC module's Sample/Hold Amplifier is connected to the analog input pin. The sample time can be started manually by setting the ADC Sample Enable (SAMP) bit in ADCx Control Register 1 (ADxCON1<1>) or started automatically by the ADC hardware. The sample time is ended manually by clearing the SAMP control bit in the user software or automatically by a conversion trigger source.

Conversion time is the time required for the ADC to convert the voltage held by the Sample/Hold Amplifier. The ADC is disconnected from the analog input pin at the end of the sample time. The ADC requires one A/D clock cycle ( $T_{AD}$ ) to convert each bit of the result plus two additional clock cycles. A total of 12  $T_{AD}$  cycles are required to perform the complete conversion in 10-bit mode. A total of 14  $T_{AD}$  cycles are required to perform the complete conversion in 12-bit mode. When the conversion time is complete, the result is loaded into the ADCxBUF0 register, the Sample/Hold Amplifier can be reconnected to the input pin and a CPU interrupt can be generated.

The sum of the sample time and the A/D conversion time provides the total conversion time. There is a minimum sample time to ensure that the Sample/Hold Amplifier provides the desired accuracy for the A/D conversion (see **16.15 "A/D Sampling Requirements"**). Furthermore, there are multiple input clock options for the ADC. You must select an input clock option that does not violate the minimum  $T_{AD}$  specification.

**Figure 16-2: ADC Sample/Conversion Sequence**

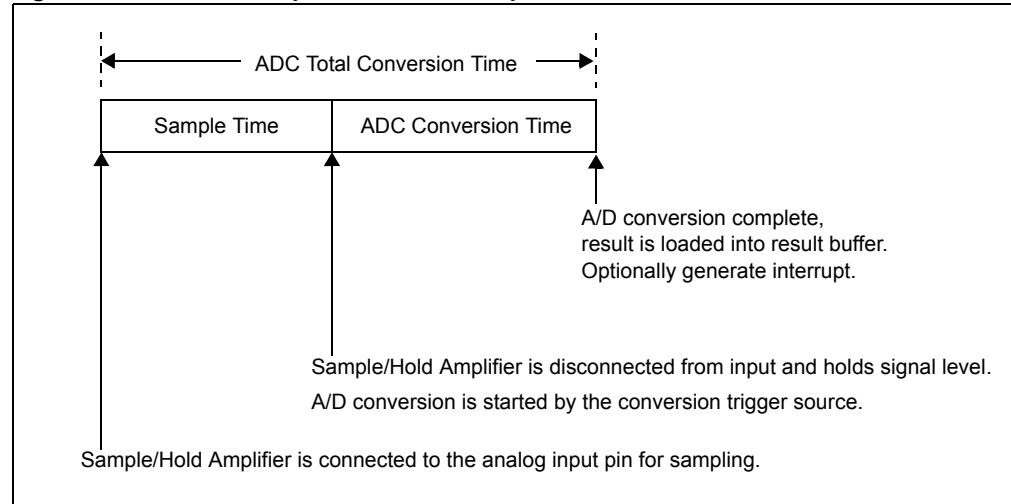

The ADC allows many options for specifying the sample/convert sequence. The sample/convert sequence can be very simple, using only one Sample/Hold amplifier. A more elaborate sample/convert sequence performs multiple conversions using more than one Sample/Hold amplifier. The 10-bit ADC configuration can use two Sample/Hold amplifiers to perform two conversions in a sample/convert sequence or four Sample/Hold amplifiers with four conversions.

The number of Sample/Hold amplifiers, or channels per sample, used in the sample/convert sequence is determined by the Channel Select (CHPS<1:0>) control bits in ADCx Control Register 2 (ADxCON2<9:8>).

**Note:** The 12-bit ADC configuration can only perform one conversion in a single sample/convert sequence. The CHPS bits are irrelevant in this case.

A sample/convert sequence that uses multiple Sample/Hold channels can be simultaneously sampled or sequentially sampled, as controlled by the Simultaneous Sample Select (SIMSAM) bit (ADxCON1<3>). Simultaneously sampling multiple signals ensures that the snapshot of the analog inputs occurs at precisely the same time for all inputs. Sequential sampling takes a snapshot of each analog input just before conversion starts on that input. The sampling of multiple inputs is not correlated.

**Figure 16-3: Simultaneous and Sequential Sampling**

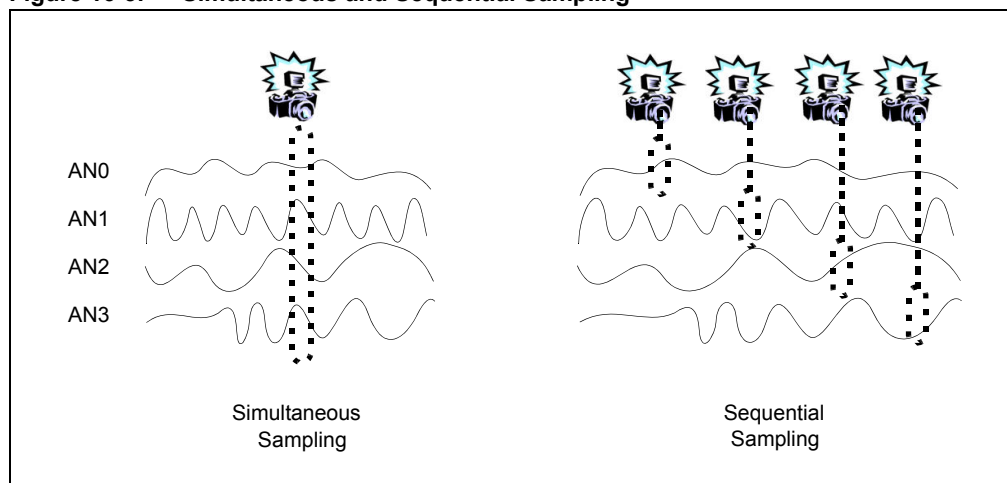

The start time for sampling can be controlled in software by setting the ADC Sample Enable (SAMP) control bit (ADxCON1<1>). The start of the sampling time can also be controlled automatically by the hardware. When the ADC module operates in the Auto-Sample mode, the Sample/Hold amplifier(s) is reconnected to the analog input pin at the end of the conversion in the sample/convert sequence. The auto-sample function is controlled by the ADC Sample Auto-Start (ASAM) control bit (ADxCON1<2>).

The conversion trigger source ends the sampling time and begins an A/D conversion or a sample/convert sequence. The conversion trigger source is selected by the Sample Clock Source Select (SSRC<2:0>) control bits (ADxCON1<7:5>). The conversion trigger can be taken from a variety of hardware sources, or can be controlled manually in software by clearing the SAMP control bit. One of the conversion trigger sources is an auto-conversion. The time between auto-conversions is set by a counter and the ADC clock. The Auto-Sample mode and auto-conversion trigger can be used together to provide endless automatic conversions without software intervention.

An interrupt can be generated at the end of each sample/convert sequence or after multiple sample/convert sequences, as determined by the value of the Samples Per Interrupt (SMPI<3:0>) control bits (ADxCON2<5:2>). The number of sample/convert sequences between interrupts can vary between 1 and 16. The total number of conversion results between interrupts is the product of the channels per sample and the SMPI<3:0> value. However, since only one conversion result is stored in ADCxBUF0, each execution of the interrupt service routine can be used to read only one conversion result.

If multiple conversion results need to be buffered, a DMA buffer should be used to store the conversion results. In this case, the SMPI<3:0> bits are used to select how often the DMA RAM buffer pointer is incremented. The frequency of incrementing the DMA RAM buffer pointer should not exceed the DMA RAM buffer length.

## 16.4 ADC MODULE CONFIGURATION

The following steps should be followed for performing an A/D conversion:

1. Select 10-bit or 12-bit mode (ADxCON1<10>)
2. Select voltage reference source to match expected range on analog inputs (ADxCON2<15:13>)
3. Select the analog conversion clock to match desired data rate with processor clock (ADxCON3<7:0>)
4. Select port pins as analog inputs (ADxPCFGH<15:0> and ADxPCFGL<15:0>)
5. Determine how inputs will be allocated to Sample/Hold channels (ADxCHS0<15:0> and ADxCHS123<15:0>)
6. Determine how many Sample/Hold channels will be used (ADxCON2<9:8>, ADxPCFGH<15:0> and ADxPCFGL<15:0>)
7. Determine how sampling will occur (ADxCON1<3>, ADxCSSH<15:0> and ADxCSSL<15:0>)
8. Select Manual or Auto Sampling
9. Select conversion trigger and sampling time.
10. Select how conversion results are stored in the buffer (ADxCON1<9:8>)
11. Select interrupt rate or DMA buffer pointer increment rate (ADxCON2<9:5>)
12. Select the number of samples in DMA buffer for each ADC module input (ADxCON4<2:0>)
13. Select the data format
14. Configure ADC interrupt (if required)
  - Clear ADxIF bit
  - Select interrupt priority (ADxIP<2:0>)
  - Set ADxIE bit
15. Configure DMA channel (if needed)
16. Turn on ADC module (ADxCON1<15>)

The options for these configuration steps are described in the subsequent sections.

## 16.5 SELECTING THE VOLTAGE REFERENCE SOURCE

The voltage references for A/D conversions are selected using the VCFG<2:0> control bits (ADxCON2<15:13>). The upper voltage reference (VREFH) and the lower voltage reference (VREFL) can be the internal AVDD and AVSS voltage rails or the VREF+ and VREF- input pins.

The external voltage reference pins can be shared with the AN0 and AN1 inputs on low pin count devices. The ADC module can still perform conversions on these pins when they are shared with the Vref+ and Vref- input pins.

The voltages applied to the external reference pins must meet certain specifications. Refer to the “Electrical Specifications” section of the device data sheet for details



## 16.6 SELECTING THE A/D CONVERSION CLOCK

The ADC module has a maximum rate at which conversions can be completed. An analog module clock,  $T_{AD}$ , controls the conversion timing. The A/D conversion requires 12 clock periods (12  $T_{AD}$ ) in the 10-bit mode and 14 clock periods (14  $T_{AD}$ ) in the 12-bit mode. The A/D conversion clock is derived from either the device instruction clock or an internal RC clock source.

The period of the A/D conversion clock is software selected using a 6-bit counter. There are 256 possible options for  $T_{AD}$ , specified by the ADC Conversion Clock Select (ADCS<7:0>) bits (ADxCON3<7:0>). Equation 16-1 gives the  $T_{AD}$  value as a function of the ADCS control bits and the device instruction cycle clock period,  $T_{CY}$ .

**Equation 16-1: A/D Conversion Clock Period**

$$T_{AD} = T_{CY}(ADCS + 1)$$

$$ADCS = \frac{T_{AD}}{T_{CY}} - 1$$

For correct A/D conversions, the A/D conversion clock ( $T_{AD}$ ) must be selected to ensure a minimum  $T_{AD}$  time of 75 nsec.

The ADC module has a dedicated internal RC clock source that can be used to perform conversions. The internal RC clock source should be used when A/D conversions are performed while the device is in Sleep mode. The internal RC oscillator is selected by setting the ADC Conversion Clock Source (ADRC) bit (ADxCON3<15>). When the ADRC bit is set, the ADCS<7:0> bits have no effect on the A/D operation.

**Figure 16-4: A/D Conversion Clock Period Block Diagram**

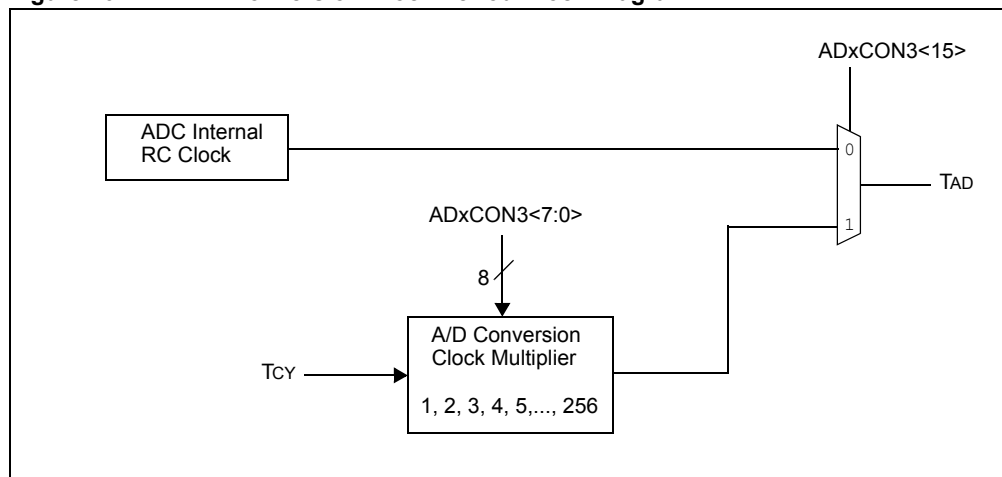

## 16.7 SELECTING ANALOG INPUTS FOR SAMPLING

All Sample/Hold Amplifiers have analog multiplexers (see Figure 16-1) on both their non-inverting and inverting inputs to select which analog input(s) are sampled. Once the sample/convert sequence is specified, the ADxCHS0 and ADxCHS123 registers determine which analog inputs are selected for each sample.

Additionally, the selected inputs can vary on an alternating sample basis or on a repeated sequence of samples.

The same analog input can be connected to two or more Sample/Hold channels to improve conversion rates.

**Note:** Different devices will have different numbers of analog inputs. Verify the analog input availability against the device data sheet.

### 16.7.1 Configuring Analog Port Pins

The ADPCFGH and ADPCFGL registers specify the input condition of device pins used as analog inputs. Along with the Data Direction (TRISx) register in the Parallel I/O Port module, these registers control the operation of the ADC pins.

A pin is configured as analog input when the corresponding PCFGn bit (ADPCFGH<n> or ADPCFGL<n>) is clear. The ADPCFGH and ADPCFGL registers are clear at Reset, causing the ADC input pins to be configured for analog input by default at Reset.

When configured for analog input, the associated port I/O digital input buffer is disabled so it does not consume current.

The port pins that are desired as analog inputs must have their corresponding TRIS bit set, specifying port input. If the I/O pin associated with an A/D input is configured as an output, the TRIS bit is cleared and the port's digital output level (VOH or VOL) is converted. After a device Reset, all TRIS bits are set.

A pin is configured as digital I/O when the corresponding PCFGn bit is set. In this configuration, the input to the analog multiplexer is connected to AVss.

**Note 1:** When the ADC Port register is read, any pin configured as an analog input reads as a '0'.  
**2:** Analog levels on any pin that is defined as a digital input (including the AN15:AN0 pins) may cause the input buffer to consume current that is out of the device's specification.

### 16.7.2 Channel 0 Input Selection

Channel 0 is the most flexible of the four Sample/Hold channels in terms of selecting analog inputs. It allows you to select any of the up to 16 analog inputs as the input to the positive input of the channel. The Channel 0 Positive Input Select for Sample A (CH0SA<4:0>) bits (ADxCHS0<4:0>) normally select the analog input for the positive input of channel 0.

You can select either VREF- or AN1 as the negative input of the channel. The CH0NA bit (ADxCHS0<7>) normally selects the analog input for the negative input of channel 0.

#### 16.7.2.1 SPECIFYING ALTERNATING CHANNEL 0 INPUT SELECTIONS

The Alternate Input Sample Mode Select (ALTS) bit (ADxCON2<0>) causes the ADC module to alternate between two sets of inputs that are selected during successive samples.

The inputs specified by CH0SA<4:0> (ADxCHS0<4:0>), CH0NA (ADxCHS0<7>), CH123SA (ADxCHS123<0>) and CH123NA<1:0> (ADxCHS123<2:1>) are collectively called the MUX A inputs. The inputs specified by CH0SB<4:0> (ADxCHS0<12:8>), CH0NB (ADxCHS0<15>), CH123SB (ADxCHS0<8>) and CH123NB<1:0> (ADxCHS0<10:9>) are collectively called the MUX B inputs. When the ALTS bit is '1', the ADC module alternates between the MUX A inputs on one group of samples and the MUX B inputs on the subsequent group of samples.

For channel 0, if the ALTS bit is '0', only the inputs specified by CH0SA<4:0> and CH0NA are selected for sampling.

If the ALTS bit is '1', on the first sample/convert sequence for channel 0, the inputs specified by CH0SA<4:0> and CH0NA are selected for sampling. On the next sample convert sequence for channel 0, the inputs specified by CH0SB<4:0> and CH0NB are selected for sampling. This pattern repeats for subsequent sample conversion sequences.

Note that if multiple channels (CHPS = 01 or 1x) and simultaneous sampling (SIMSAM = 1) are specified, alternating inputs change every sample because all channels are sampled on every sample time. If multiple channels (CHPS = 01 or 1x) and sequential sampling (SIMSAM = 0) are specified, alternating inputs change only on each sample of a particular channel.

#### 16.7.2.2 SCANNING THROUGH SEVERAL INPUTS WITH CHANNEL 0

Channel 0 can scan through a selected vector of inputs. The CSCNA bit (ADxCON2<10>) enables the CH0 channel inputs to be scanned across a selected number of analog inputs. When CSCNA is set, the CH0SA<4:0> bits are ignored.

The ADCx Input Scan Select Register High (ADxCSSH) and ADCx Input Scan Select Register Low (ADxCSSL) registers specify the inputs to be scanned. Each bit in these registers corresponds to an analog input. Bit 0 corresponds to AN0, bit 1 corresponds to AN1 and so on. If a particular bit is '1', the corresponding input is part of the scan sequence. The inputs are always scanned from lower to higher numbered inputs, starting at the first selected channel after each interrupt occurs.

**Note:** If the number of scanned inputs selected is greater than the number of samples taken per interrupt, the higher numbered inputs will not be sampled.

The ADxCSSH and ADxCSSL bits only specify the input of the positive input of the channel. The CH0NA bit still selects the input of the negative input of the channel during scanning.

If the ALTS bit is '1', the scanning only applies to the MUX A input selection. The MUX B input selection, as specified by the CH0SB<4:0>, still selects the alternating channel 0 input. When the input selections are programmed in this manner, the channel 0 input alternates between a set of scanning inputs specified by the ADxCSSL register and a fixed input specified by the CH0SB bits.

### 16.7.3 Channel 1, 2 and 3 Input Selection

Channel 1, 2 and 3 can sample a subset of the analog input pins. Channel 1, 2 and 3 can select one of two groups of three inputs.

The CH123SA bit (ADxCHS123<0>) selects the source for the positive inputs of channel 1, 2 and 3. Clearing CH123SA selects AN0, AN1 and AN2 as the analog source to the positive inputs of channel 1, 2 and 3, respectively. Setting CH123SA selects AN3, AN4 and AN5 as the analog source.

The CH123NA<1:0> bits (ADxCHS<2:1>) select the source for the negative inputs of channel 1, 2 and 3. Programming CH123NA = 0x selects VREF- as the analog source for the negative inputs of channels 1, 2 and 3. Programming CH123NA = 10 selects AN6, AN7 and AN8 as the analog source to the negative inputs of channels 1, 2 and 3 respectively. Programming CH123NA = 11 selects AN9, AN10 and AN11 as the analog source.

## 16.7.3.1 SELECTING MULTIPLE CHANNELS FOR A SINGLE ANALOG INPUT

The analog input multiplexer can be configured so that the same input pin is connected to two or more Sample/Hold channels. The ADC converts the value held on one Sample/Hold channel, while the second Sample/Hold channel acquires a new input sample.

## 16.7.3.2 SPECIFYING ALTERNATING CHANNEL 1, 2 AND 3 INPUT SELECTIONS

As with the channel 0 inputs, the ALTS bit (ADxCON2<0>) causes the ADC module to alternate between two sets of inputs that are selected during successive samples for channel 1,2 and 3.

The MUX A inputs specified by CH123SA and CH123NA<1:0> always select the input when ALTS = 0.

The MUX A inputs alternate with the MUX B inputs specified by CH123SB and CH123NB<1:0> when ALTS = 1.

## 16.8 ENABLING THE MODULE

When the ADC Operating Mode (ADON) bit (ADxCON1<15>) is '1', the ADC module is in Active mode and is fully powered and functional.

When ADON is '0', the ADC module is disabled. The digital and analog portions of the circuit are turned off for maximum current savings.

In order to return to the Active mode from the Off mode, the user must wait for the analog stages to stabilize. For the stabilization time, refer to the Electrical Characteristics section of the device data sheet.

<b>Note:</b> The SSRC<2:0>, SIMSAM, ASAM, CHPS<1:0>, SMPI<3:0>, BUFM and ALTS bits, as well as the ADxCON3, ADxCSSH and ADxCSSL registers, should not be written to while ADON = 1. This would lead to indeterminate results.
---

## 16.9 SPECIFYING SAMPLE/CONVERSION CONTROL

The ADC module uses four Sample/Hold amplifiers and one A/D Converter in the 10-bit mode. The module can perform 1, 2 or 4 input samples and A/D conversions per sample/convert sequence.

### 16.9.1 Number of Sample/Hold Channels

The CHPS<1:0> control bits (ADxCON2<9:8>) are used to select how many Sample/Hold amplifiers are used by the ADC module during sample/conversion sequences. The following three options can be selected:

- CH0 only
- CH0 and CH1
- CH0, CH1, CH2, CH3

The CHPS control bits work in conjunction with the SIMSAM (simultaneous sample) control bit (ADxCON1<3>). The CHPS and SIMSAM bits are not relevant in 12-bit mode as there is only one Sample/Hold amplifier.

### 16.9.2 Simultaneous Sampling Enable

Some applications can require that multiple signals be sampled simultaneously. The SIMSAM control bit (ADxCON1<3>) works in conjunction with the CHPS control bits and controls the sample/convert sequence for multiple channels as shown in Table 16-1. The SIMSAM control bit has no effect on the ADC module operation if CHPS<1:0> = 00. If more than one Sample/Hold amplifier is enabled by the CHPS control bits and the SIMSAM bit is '0', the two or four selected channels are sampled and converted sequentially with two or four sampling periods. If the SIMSAM bit is '1', two or four selected channels are sampled simultaneously with one sampling period. The channels are then converted sequentially. The SIMSAM bit is not relevant in 12-bit mode as there is only one S/H.

**Table 16-1: Sample/Conversion Control Options**

CHPS<1:0>	SIMSAM	Sample/Conversion Sequence	# of Sample/ Convert Cycles to Complete	Example
00	x	Sample CH0, Convert CH0	1	Figure 16-5, Figure 16-6, Figure 16-7, Figure 16-8, Figure 16-11, Figure 16-12, Figure 16-17, Figure 16-18
01	0	Sample CH0, Convert CH0 Sample CH1, Convert CH1	2	
1x	0	Sample CH0, Convert CH0 Sample CH1, Convert CH1 Sample CH2, Convert CH2 Sample CH3, Convert CH3	4	Figure 16-10, Figure 16-14, Figure 16-22
01	1	Sample CH0, CH1 simultaneously Convert CH0 Convert CH1	1	Figure 16-20
1x	1	Sample CH0, CH1, CH2, CH3 simultaneously Convert CH0 Convert CH1 Convert CH2 Convert CH3	1	Figure 16-9, Figure 16-13, Figure 16-19, Figure 16-21

## 16.10 HOW TO START SAMPLING

### 16.10.1 Manual

Setting the SAMP bit (ADxCON1<1>) causes the ADC to begin sampling. One of several options can be used to end sampling and complete the conversions. Sampling does not resume until the SAMP bit is once again set. For an example, see Figure 16-5.

### 16.10.2 Automatic

Setting the ASAM bit (ADxCON1<2>) causes the ADC to automatically begin sampling a channel whenever a conversion is not active on that channel. One of several options can be used to end sampling and complete the conversions. If the SIMSAM bit specifies sequential sampling, sampling on a channel resumes after the conversion of that channel completes. If the SIMSAM bit specifies simultaneous sampling, sampling on a channel resumes after the conversion of all channels completes. For an example, see Figure 16-6.

## 16.11 HOW TO STOP SAMPLING AND START CONVERSIONS

The conversion trigger source terminates sampling and starts a selected sequence of conversions. The Sample Clock Source Select (SSRC<2:0>) bits (ADxCON1<7:5>) select the source of the conversion trigger.

**Note:** The available conversion trigger sources can vary depending on the device variant. Please refer to the specific device data sheet for the available conversion trigger sources.

**Note:** The SSRC<2:0> selection bits should not be changed when the ADC module is enabled. If you change the conversion trigger source, be sure the ADC module is disabled first by clearing the ADON bit (ADxCON1<15>).

### 16.11.1 Manual

When SSRC<2:0> = 000, the conversion trigger is under software control. Clearing the SAMP bit (ADxCON1<1>) starts the conversion sequence.

Figure 16-5 is an example where setting the SAMP bit initiates sampling and clearing the SAMP bit terminates sampling and starts conversion. The user software must time the setting and clearing of the SAMP bit to ensure adequate sampling time of the input signal. See Example 16-1 for code example.

**Figure 16-5: Converting 1 Channel, Manual Sample Start, Manual Conversion Start**

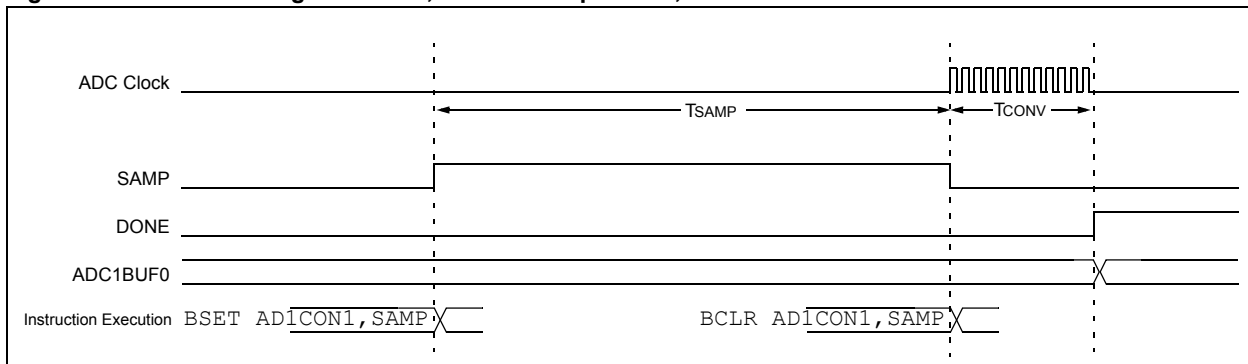

**Example 16-1: Converting 1 Channel, Manual Sample Start, Manual Conversion Start Code**

```

AD1PCFGL = 0xFFFFB;           // all PORTB = Digital; RB2 = analog
AD1CON1 = 0x0000;             // SAMP bit = 0 ends sampling ...
                                // and starts converting
AD1CHS0 = 0x0002;            // Connect RB2/AN2 as CH0 input ..
                                // in this example RB2/AN2 is the input

AD1CSSL = 0;
AD1CON3 = 0x0002;            // Manual Sample, Tad = internal 2 Tcy
AD1CON2 = 0;

AD1CON1bits.ADON = 1;        // turn ADC ON
while (1)                    // repeat continuously
{
    AD1CON1bits.SAMP = 1;     // start sampling ...
    DelayNmSec(100);         // for 100 mS
    AD1CON1bits.SAMP = 0;     // start Converting
    while (!AD1CON1bits.DONE); // conversion done?
    ADCValue = ADC1BUF0;      // yes then get ADC value
}
    
```

Figure 16-6 is an example where setting the ASAM bit initiates automatic sampling and clearing the SAMP bit terminates sampling and starts conversion. After the conversion completes, the ADC module automatically returns to a sampling state. The SAMP bit is automatically set at the start of the sample interval. The user software must time the clearing of the SAMP bit to ensure adequate sampling time of the input signal, understanding that the time between clearing of the SAMP bit includes the conversion time as well as the sampling time. See Example 16-2 for code example.

**Figure 16-6: Converting 1 Channel, Automatic Sample Start, Manual Conversion Start**

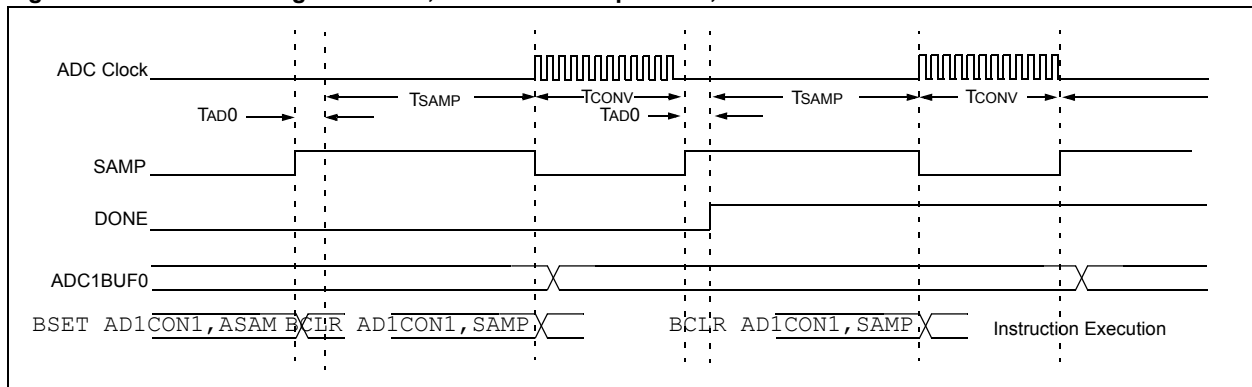

## Example 16-2: Converting 1 Channel, Automatic Sample Start, Manual Conversion Start Code

```

AD1PCFGL = 0xFF7F;           // all PORTB = Digital but RB7 = analog
AD1CON1 = 0x0004;           // ASAM bit = 1 implies sampling ..
                               // starts immediately after last
                               // conversion is done
AD1CHS0= 0x0007;           // Connect RB7/AN7 as CH0 input ..
                               // in this example RB7/AN7 is the input
AD1CSSL = 0;
AD1CON3 = 0x0002;           // Sample time manual, Tad = internal 2 Tcy
AD1CON2 = 0;

AD1CON1bits.ADON = 1;       // turn ADC ON
while (1)                   // repeat continuously
{
    DelayNmSec(100);        // sample for 100 mS
    AD1CON1bits.SAMP = 0;    // start Converting
    while (!AD1CON1bits.DONE); // conversion done?
    ADCValue = ADC1BUF0;     // yes then get ADC value
}                             // repeat
    
```

### 16.11.2 Clocked Conversion Trigger

When  $SSRC\langle 2:0 \rangle = 111$ , the conversion trigger is under A/D clock control. The Auto Sample Time ( $SAMC\langle 4:0 \rangle$ ) bits ( $AD1CON3\langle 12:8 \rangle$ ) select the number of  $TAD$  clock cycles between the start of sampling and the start of conversion. This trigger option provides the fastest conversion rates on multiple channels. After the start of sampling, the ADC module counts a number of  $TAD$  clocks specified by the  $SAMC$  bits.

#### Equation 16-2: Clocked Conversion Trigger Time

$$T_{SMP} = SAMC\langle 4:0 \rangle * TAD$$

When using only one Sample/Hold channel or simultaneous sampling,  $SAMC$  must always be programmed for at least one clock cycle. When using multiple Sample/Hold channels with sequential sampling, programming  $SAMC$  for zero clock cycles results in the fastest possible conversion rate. See Example 16-3 for code example.

Figure 16-7: Converting 1 Channel, Manual Sample Start,  $TAD$  Based Conversion Start

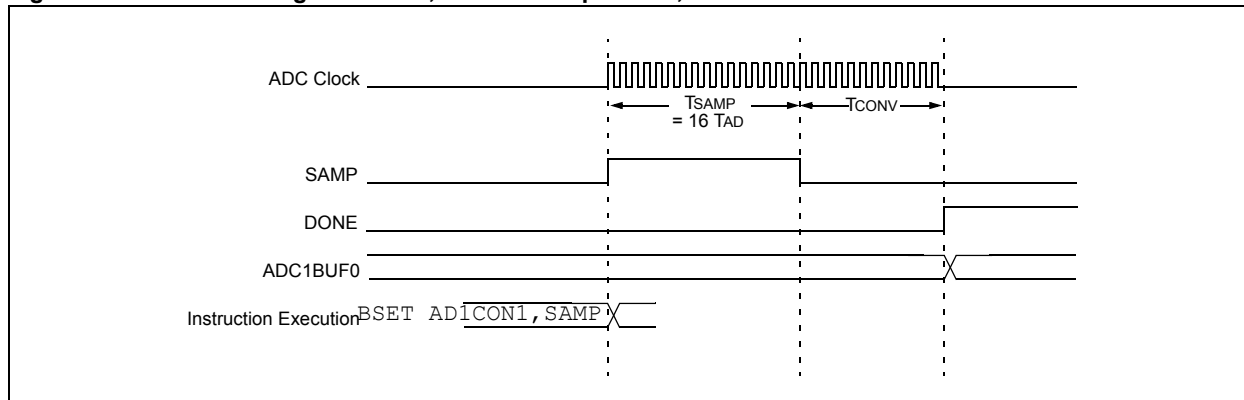



**Example 16-3: Converting One Channel, Manual Sample Start, TAD Based Conversion Start Code**

```

AD1PCFGL = 0xEFFF;           // all PORTB = Digital; RB12 = analog
AD1CON1 = 0x00E0;           // SSRC bit = 111 implies internal
                             // counter ends sampling and starts
                             // converting.
AD1CHS0= 0x000C;           // Connect RB12/AN12 as CH0 input ..
                             // in this example RB12/AN12 is the input
AD1CSSL = 0;
AD1CON3 = 0x1F02;           // Sample time = 31Tad, Tad = internal 2 Tcy
AD1CON2 = 0;

AD1CON1bits.ADON = 1;       // turn ADC ON
while (1)                   // repeat continuously
{
    AD1CON1bits.SAMP = 1;    // start sampling then ...
                             // after 31Tad go to conversion
    while (!AD1CON1bits.DONE); // conversion done?
    ADCValue = ADC1BUF0;     // yes then get ADC value
}                             // repeat
    
```

**16.11.2.1 FREE RUNNING SAMPLE CONVERSION SEQUENCE**

As shown in Figure 16-8, using the Auto-Convert Conversion Trigger mode (SSRC = 111) in combination with the Auto-Sample Start mode (ASAM = 1), allows the ADC module to schedule sample/conversion sequences with no intervention by the user or other device resources. This “Clocked” mode allows continuous data collection after module initialization.

**Note:** This A/D configuration must be enabled for the conversion rate of 750 ksp/s.

**Figure 16-8: Converting One Channel, Auto-Sample Start, TAD Based Conversion Start**

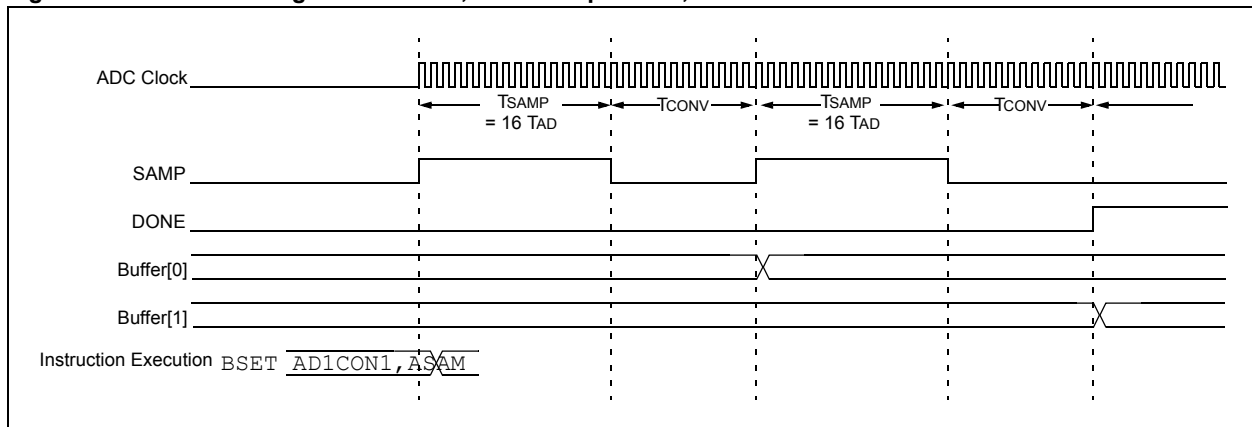

## 16.11.2.2 MULTIPLE CHANNELS WITH SIMULTANEOUS SAMPLING

As shown in Figure 16-9 when using simultaneous sampling, the SAMC value specifies the sampling time. In the example, SAMC specifies a sample time of 3 TAD. Because automatic sample start is active, sampling starts on all channels after the last conversion ends and continues for three A/D clocks.

**Figure 16-9: Converting Four Channels, Auto-Sample Start, TAD Conversion Start, Simultaneous Sampling**

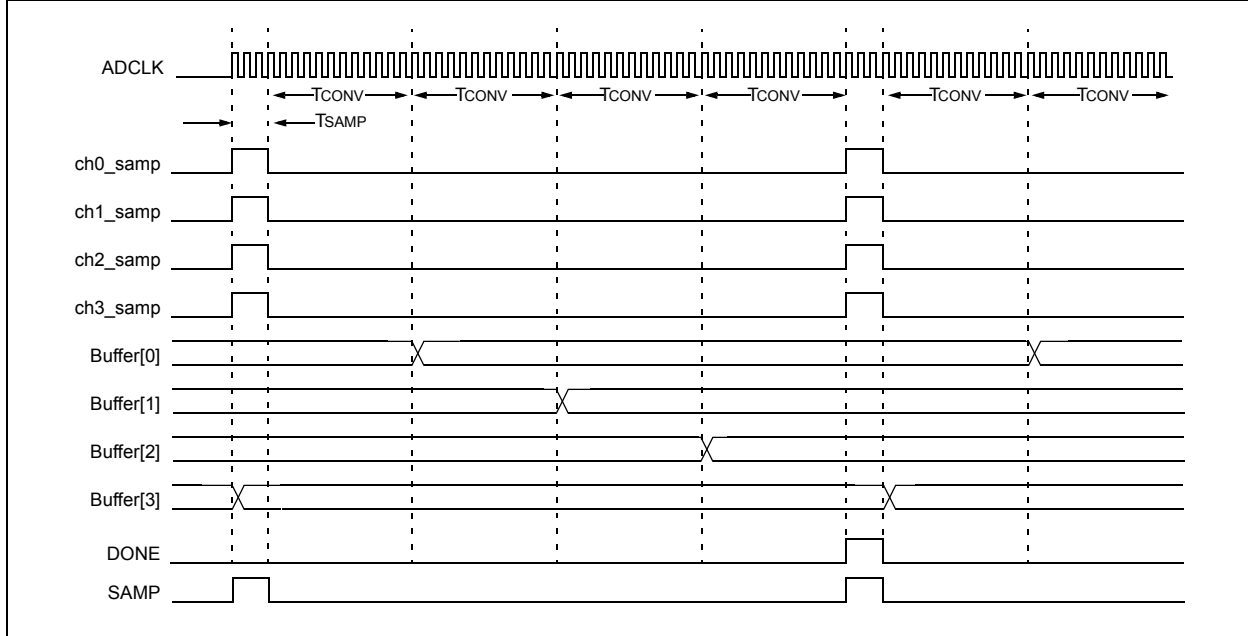

## 16.11.2.3 MULTIPLE CHANNELS WITH SEQUENTIAL SAMPLING

As shown in Figure 16-10 when using sequential sampling, the sample time precedes each conversion time. In the example, 3 TAD clocks are added for sample time for each channel.

**Figure 16-10: Converting Four Channels, Auto-Sample Start, TAD Conversion Start, Sequential Sampling**

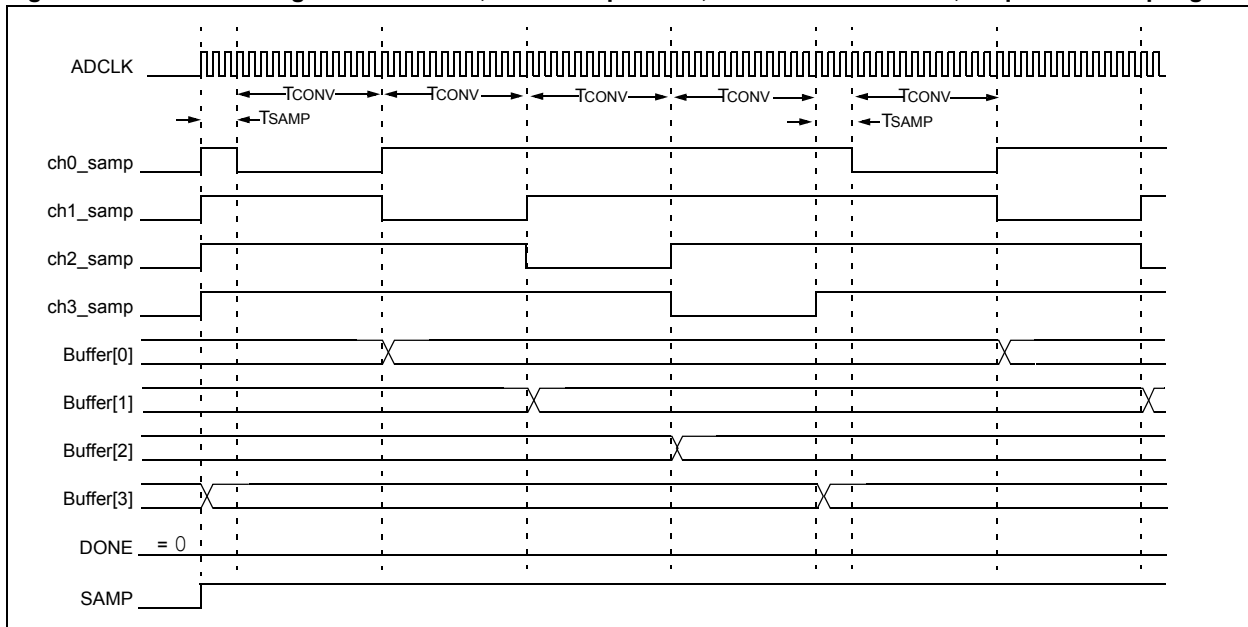

#### 16.11.2.4 SAMPLE TIME CONSIDERATIONS USING CLOCKED CONVERSION TRIGGER AND AUTOMATIC SAMPLING

Different sample/conversion sequences provide different available sampling times for the Sample/Hold channel to acquire the analog signal. The user must ensure the sampling time exceeds the sampling requirements, as outlined in **Section 16.15 “A/D Sampling Requirements”**.

Assuming that the ADC module is set for automatic sampling and using a clocked conversion trigger, the sampling interval is determined by the sample interval specified by the SAMC bits.

If the SIMSAM bit specifies simultaneous sampling or only one channel is active, the sampling time is the period specified by the SAMC bit.

##### Equation 16-3: Available Sampling Time, Simultaneous Sampling

$$T_{SMP} = SAMC<4:0> * T_{AD}$$

If the SIMSAM bit specifies sequential sampling, the total interval used to convert all channels is the number of channels times the sampling time and conversion time. The sampling time for an individual channel is the total interval minus the conversion time for that channel.

##### Equation 16-4: Available Sampling Time, Simultaneous Sampling

$$T_{SEQ} = \text{Channels per Sample (CH/S)} * ((SAMC<4:0> * T_{AD}) + \text{Conversion Time (T}_{CONV})$$

$$T_{SMP} = (T_{SEQ} - T_{CONV})$$

**Note 1:** CH/S specified by CHPS<1:0> bits.

**2:** TSEQ is the total time for the sample/convert sequence.

### 16.11.3 Event Trigger Conversion Start

It is often desirable to synchronize the end of sampling and the start of conversion with some other time event. The ADC module can use one of two sources as a conversion trigger:

- External INT trigger
- GP Timer Compare trigger

#### 16.11.3.1 EXTERNAL INT TRIGGER

When SSRC<2:0> = 001, the A/D conversion is triggered by an active transition on the INT0 pin. The INT0 pin can be programmed for either a rising edge input or a falling edge input.

#### 16.11.3.2 GP TIMER COMPARE TRIGGER

The ADC is configured in this Trigger mode by setting SSRC<2:0> = 010. When a match occurs between the 32-bit timer TMR3/TMR2 and the 32-bit Combined Period register PR3/PR2, a special ADC trigger event signal is generated by Timer3. This feature does not exist for the TMR5/TMR4 timer pair. Refer to **Section 11. “Timers”** for more details. Check for the most recent documentation on the Microchip website at [www.microchip.com](http://www.microchip.com).

#### 16.11.3.3 SYNCHRONIZING A/D OPERATIONS TO INTERNAL OR EXTERNAL EVENTS

Modes where an external event trigger pulse ends sampling and starts conversion (SSRC<2:0> = 001, 10, 011) can be used in combination with auto-sampling (ASAM = 1) to cause the ADC module to synchronize the sample conversion events to the trigger pulse source. For example, in Figure 16-12, where SSRC<2:0> = 010 and ASAM = 1, the ADC module always ends sampling and starts conversions synchronously with the timer compare trigger event. The ADC has a sample conversion rate that corresponds to the timer comparison event rate.

# PIC24H Family Reference Manual

**Figure 16-11: Converting One Channel, Manual Sample Start, Conversion Trigger Based Conversion Start**

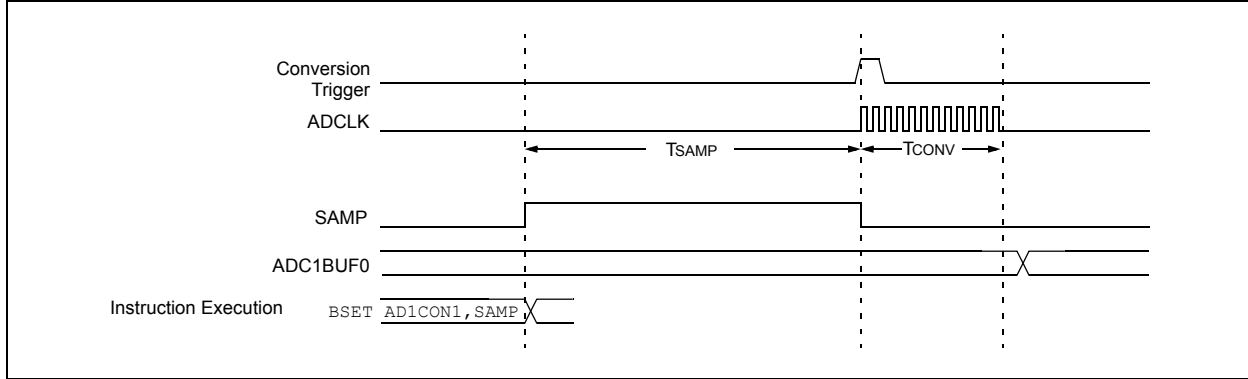

**Figure 16-12: Converting One Channel, Auto-Sample Start, Conversion Trigger Based Conversion Start**

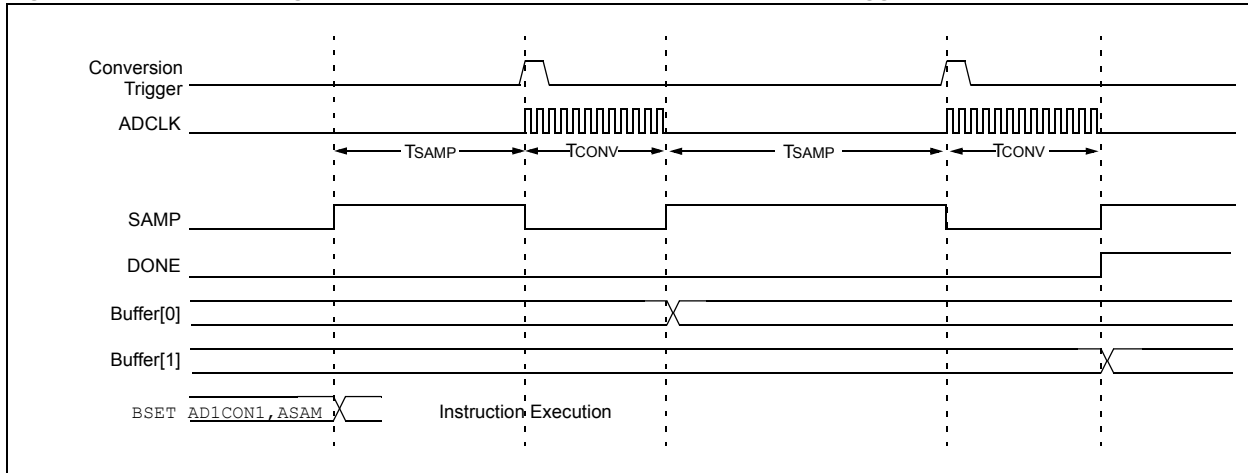

## 16.11.3.4 MULTIPLE CHANNELS WITH SIMULTANEOUS SAMPLING

As shown in Figure 16-13, when simultaneous sampling is used, sampling starts on all channels after the ASAMP bit is set or when the last conversion ends. Sampling stops and conversions start when the conversion trigger occurs.

**Figure 16-13: Converting Four Channels, Auto-Sample Start, Trigger Conversion Start, Simultaneous Sampling**

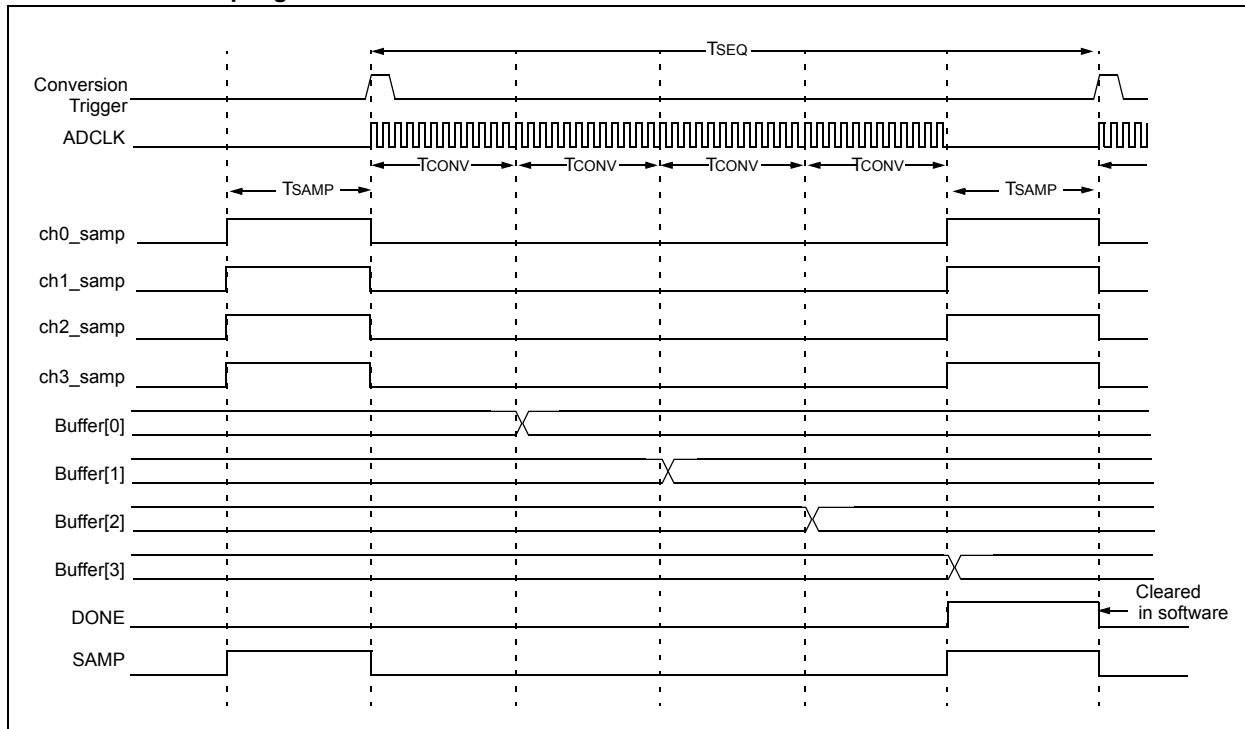

## 16.11.3.5 MULTIPLE CHANNELS WITH SEQUENTIAL SAMPLING

As shown in Figure 16-14 when sequential sampling is used, sampling for a particular channel stops just prior to converting that channel and resumes after the conversion has stopped.

**Figure 16-14: Converting Four Channels, Auto-Sample Start, Trigger Conversion Start, Sequential Sampling**

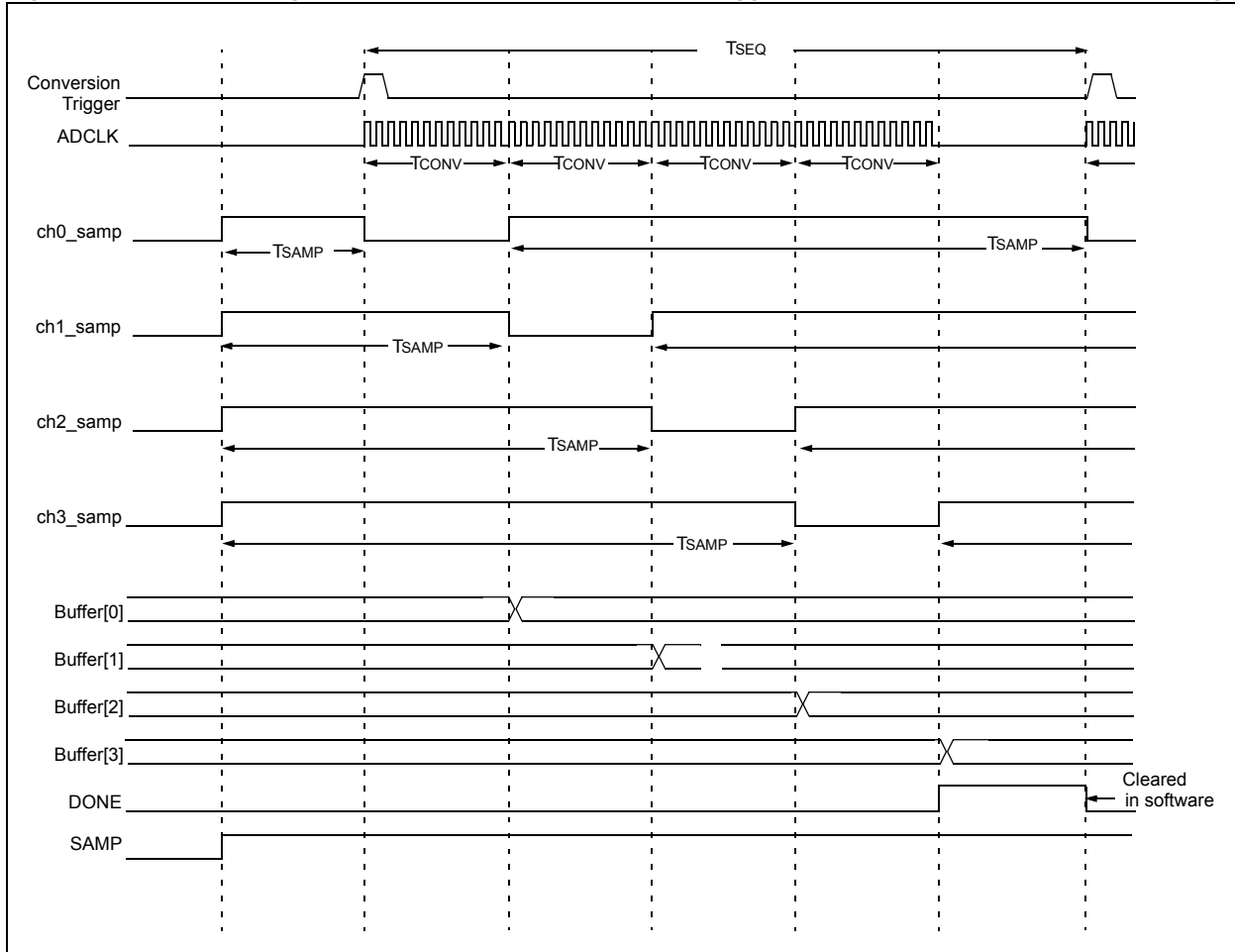

## 16.11.3.6 SAMPLE TIME CONSIDERATIONS FOR AUTOMATIC SAMPLING/CONVERSION SEQUENCES

Different sample/conversion sequences provide different available sampling times for the Sample/Hold channel to acquire the analog signal. You must ensure that the sampling time exceeds the sampling requirements, as outlined in **Section 16.15 “A/D Sampling Requirements”**.

Assuming that the ADC module is set for automatic sampling and an external trigger pulse is used as the conversion trigger, the sampling interval is a portion of the trigger pulse interval.

If the SIMSAM bit specifies simultaneous sampling, the sampling time is the trigger pulse period less the time required to complete the specified conversions.

### Equation 16-5: Available Sampling Time, Simultaneous Sampling

$$T_{SMP} = \text{Trigger Pulse Interval (TSEQ)} - \text{Channels per Sample (CH/S)} * \text{Conversion Time (TCONV)}$$

$$T_{SMP} = T_{SEQ} - (CH/S * T_{CONV})$$

**Note 1:** CH/S is specified by CHPS<1:0> bits

**2:** TSEQ is the trigger pulse interval time

If the SIMSAM bit specifies sequential sampling, the sampling time is the trigger pulse period less the time required to complete only one conversion.

### Equation 16-6: Available Sampling Time, Sequential Sampling

$$T_{SMP} = \text{Trigger Pulse Interval (TSEQ)} - \text{Conversion Time (TCONV)}$$

$$T_{SMP} = T_{SEQ} - T_{CONV}$$

**Note:** TSEQ is the trigger pulse interval time

## 16.12 CONTROLLING SAMPLE/CONVERSION OPERATION

The application software can poll the SAMP (AD1CON1<1>) and DONE (AD1CON1<0>) bits to keep track of A/D operations or the ADC module can interrupt the CPU when conversions are complete. The application software can also abort A/D operations, if necessary.

### 16.12.1 Monitoring Sample/Conversion Status

The SAMP and DONE bits indicate the sampling state and the conversion state of the ADC, respectively. Generally, when the SAMP bit clears, indicating end of sampling, the DONE bit is automatically set, indicating end of conversion. If both SAMP and DONE are '0', the ADC is in an inactive state. In some operational modes, the SAMP bit can also invoke and terminate sampling.

### 16.12.2 Generating an ADC Interrupt

The SMPI<3:0> bits (ADxCON2<5:2>) control the generation of interrupts. The interrupt occurs some number of sample/conversion sequences after starting sampling and re-occurs on each equivalent number of samples. Note that the interrupts are specified in terms of samples and not in terms of conversions or data samples in the buffer memory.

If DMA transfers are not enabled, having a non-zero SMPI<3:0> value results in overwriting the data in the ADCxBUF0 register. For example, if SMPI<3:0> = 0011, then every 4th conversion result can be read in the ADC Interrupt Service Routine. However, if channel scanning is enabled, the SMPI<3:0> bits must be set to one less than the number of channels to be scanned. Similarly, if alternate sampling is enabled, the SMPI<3:0> bits must be set to '0001'.

If DMA transfers are enabled, the SMPI<3:0> bit must be cleared, except when channel scanning or alternate sampling is used. Please refer to **Section 16.13 "Specifying Conversion Results Buffering"** for more details on SMPI<3:0> setup requirements.

When the SIMSAM bit (ADxCON1<3>) specifies sequential sampling, regardless of the number of channels specified by the CHPS<1:0> bits (ADxCON2<9:8>), the ADC module samples once for each conversion and data sample in the buffer. The value specified by the DMAxCNT register for the DMA channel being used corresponds to the number of data samples in the buffer.

When the SIMSAM bit specifies simultaneous sampling, the number of data samples in the buffer is related to the CHPS<1:0> bits. Algorithmically, the channels per sample (CH/S) times the number of samples results in the number of data sample entries in the buffer. To avoid loss of data in the buffer due to overruns, the DMAxCNT register must be set to the desired buffer size.

Disabling the ADC interrupt is not done with the SMPI<3:0> bits. To disable the interrupt, clear the ADxIE analog module interrupt enable bit.

### 16.12.3 Aborting Sampling

Clearing the SAMP bit while in Manual Sampling mode terminates sampling but can also start a conversion if SSRC<2:0> = 000.

Clearing the ASAM bit while in Automatic Sampling mode does not terminate an on going sample/convert sequence, however, sampling does not automatically resume after subsequent conversions.

### 16.12.4 Aborting a Conversion

Clearing the ADON (ADxCON1<15>) bit during a conversion aborts the current conversion. The ADC Result register pair is NOT updated with the partially completed A/D conversion sample. That is, the corresponding ADC1BUF0 buffer location continues to contain the value of the last completed conversion (or the last value written to the buffer).



### 16.13 SPECIFYING CONVERSION RESULTS BUFFERING

The ADC module contains a single-word, read-only, dual-port register (ADCxBUF0), which stores the A/D conversion result. If more than one conversion result needs to be buffered before triggering an interrupt, DMA data transfers can be used. Both ADC channels (ADC1 and ADC2) can trigger a DMA data transfer. Depending on which ADC channel is selected as the DMA IRQ source, a DMA transfer occurs when the ADC Conversion Complete Interrupt Flag Status (AD1IF or AD2IF) bit in the Interrupt Flag Status Register (IFS0 or IFS1, respectively) in the Interrupt Module gets set as a result of a sample conversion sequence.

The result of every A/D conversion is stored in the ADCxBUF0 register. If a DMA channel is not enabled for the ADC module, each result should be read by the user application before it gets overwritten by the next conversion result. However, if DMA is enabled, multiple conversion results can be automatically transferred from ADCxBUF0 to a user-defined buffer in the DMA RAM area. Thus, the application can process several conversion results with minimal software overhead.

**Note:** For information about how to configure a DMA channel to transfer data from the ADC buffer and define a corresponding DMA buffer area from where the data can be accessed by the application, please refer to **Section 22. “Direct Memory Access (DMA)”**. For specific information about the Interrupt registers, please refer to **Section 6. “Interrupts”**.

The DMA Buffer Build Mode (ADDMABM) bit in ADCx Control Register 1 (ADxCON1<12>) determines how the conversion results are filled in the DMA RAM buffer area being used for the ADC. If this bit is set (ADDMABM = 1), DMA buffers are written in the order of conversion. The ADC module provides an address to the DMA channel that is the same as the address used for the non-DMA stand-alone buffer. If the ADDMABM bit is cleared, then DMA buffers are written in Scatter/Gather mode. The ADC module provides a Scatter/Gather address to the DMA channel, based on the index of the analog input and the size of the DMA buffer.

#### 16.13.1 USING DMA IN THE SCATTER/GATHER MODE

When the ADDMABM bit is '0', the Scatter/Gather mode is enabled. In this mode, the DMA channel must be configured for Peripheral Indirect Addressing. The DMA buffer is divided into consecutive memory blocks corresponding to all available analog inputs (out of AN0 - AN31). Each conversion result for a particular analog input is automatically transferred by the ADC module to the corresponding block within the user-defined DMA buffer area. Successive samples for the same analog input are stored in sequence within the block assigned to that input.

The number of samples that need to be stored in the DMA buffer for each analog input is specified by the DMABL<2:0> bits (ADxCON4<2:0>).

The buffer locations within each block are accessed by the ADC module using an internal pointer, which is initialized to '0' when the ADC module is enabled. When this internal pointer reaches the value defined by the DMABL<2:0> bits, it gets reset to '0'. This ensures that conversion results of one analog input do not corrupt the conversion results of other analog inputs. The rate at which this internal pointer is incremented when data is written to the DMA buffer is specified by the SMP1<3:0> bits.

When no channel scanning or alternate sampling is required, SMP1 <3:0> should be cleared, implying that the pointer will increment on every sample. Thus, it is theoretically possible to use every location in the DMA buffer for the blocks assigned to the analog inputs being sampled.

In the example illustrated in Figure 16-15, it can be observed that the conversion results for the AN0, AN1 and AN2 inputs are stored in sequence, leaving no unused locations in their corresponding memory blocks. However, for the four analog inputs (AN4, AN5, AN6 and AN7) that are scanned by CH0, the first location in the AN5 block, the first two locations in the AN6 block and the first three locations in the AN7 block are unused, resulting in a relatively inefficient arrangement of data in the DMA buffer.

# PIC24H Family Reference Manual

---

When scanning is used, and no simultaneous sampling is performed (SIMSAM = 0), SMPI<3:0> should be set to one less than the number of inputs being scanned. For example, if CHPS<1:0> = 00 (only one Sample/Hold channel is used), and AD1CSSL = 0xFFFF, indicating that AN0-AN15 are being scanned, then set SMPI<3:0> = 1111 so that the internal pointer is incremented only after every 16th sample/conversion sequence. This avoids unused locations in the blocks corresponding to the analog inputs being scanned.

Similarly, if ALTS=1, indicating that alternating analog input selections are used, then SMPI<3:0> is set to '0001', thereby incrementing the internal pointer after every 2nd sample.

**Note:** The module does not perform limit checks on the generated buffer addresses. For example, you must ensure that the LS bits of the DMAxSTA or DMAxSTB register used are indeed '0'. Also, the number of potential analog inputs multiplied by the buffer size specified by DMABL<2:0> must not exceed the total length of the DMA buffer.

**Figure 16-15: DMA Buffer in Scatter/Gather Mode**

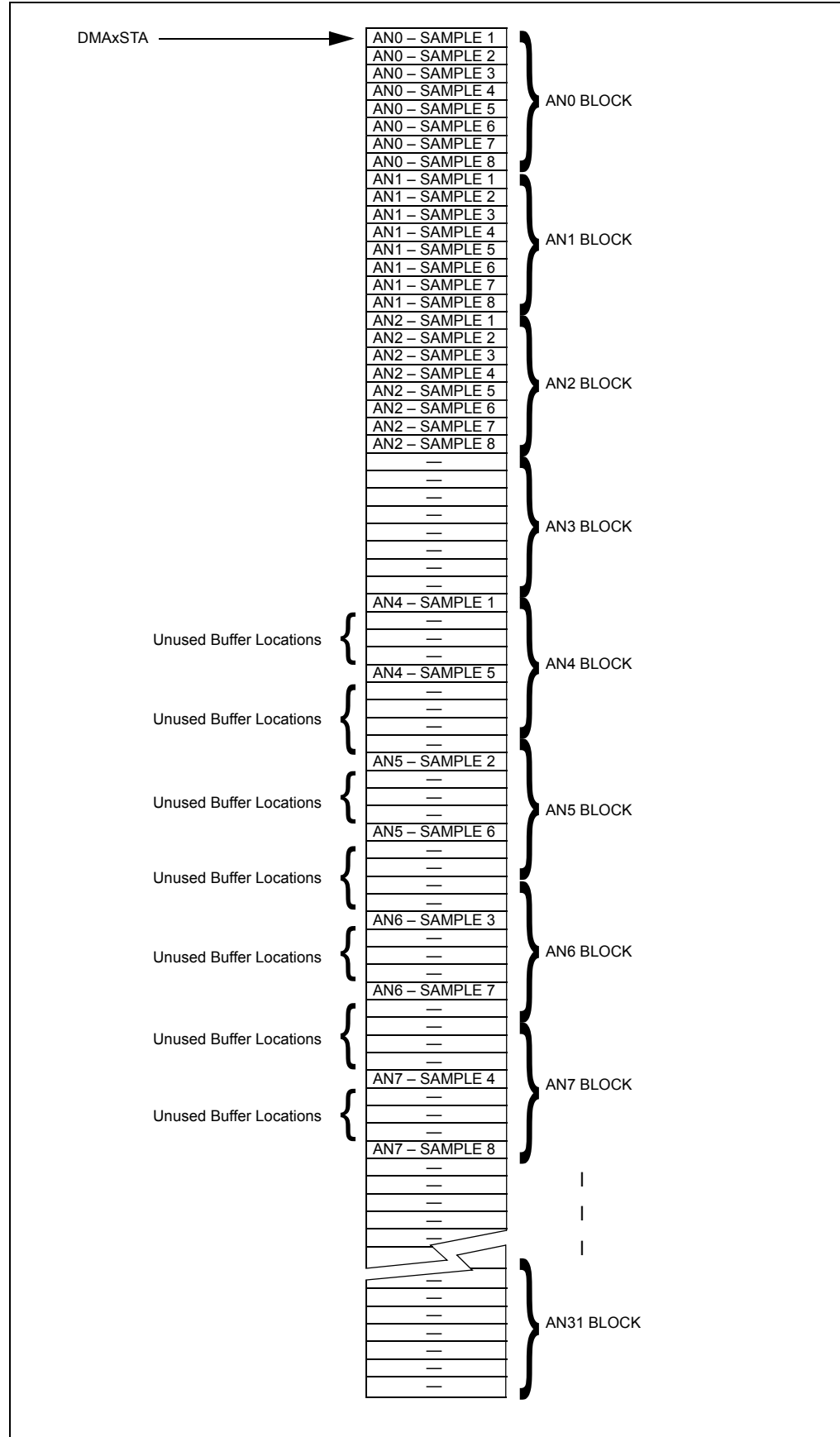

## 16.13.2 USING DMA IN THE CONVERSION ORDER MODE

When the AADMABM bit (ADCON1<12>) = 1, the Conversion Order mode is enabled. In this mode, the DMA channel can be configured for Register Indirect or Peripheral Indirect Addressing. All conversion results are stored in the user-specified DMA buffer area in the same order in which the conversions are performed by the ADC module. In this mode, the buffer is not divided into blocks allocated to different analog inputs. Rather the conversion results from different inputs are interleaved according to the specific buffer fill modes being used.

In this configuration, the buffer pointer is always incremented by one word. In this case, the SMP1<3:0> bits (ADxCON2<5:2>) must be cleared and the DMABL<2:0> bits (ADxCON4<2:0>) are ignored.

Figure 16-16 illustrates an example identical to the configuration in Figure 16-15, but using the Conversion Order mode. In this example, the DMAxCNT register has been configured to generate the DMA interrupt after 16 conversion results have been obtained.

**Figure 16-16: DMA Buffer in Conversion Order Mode**

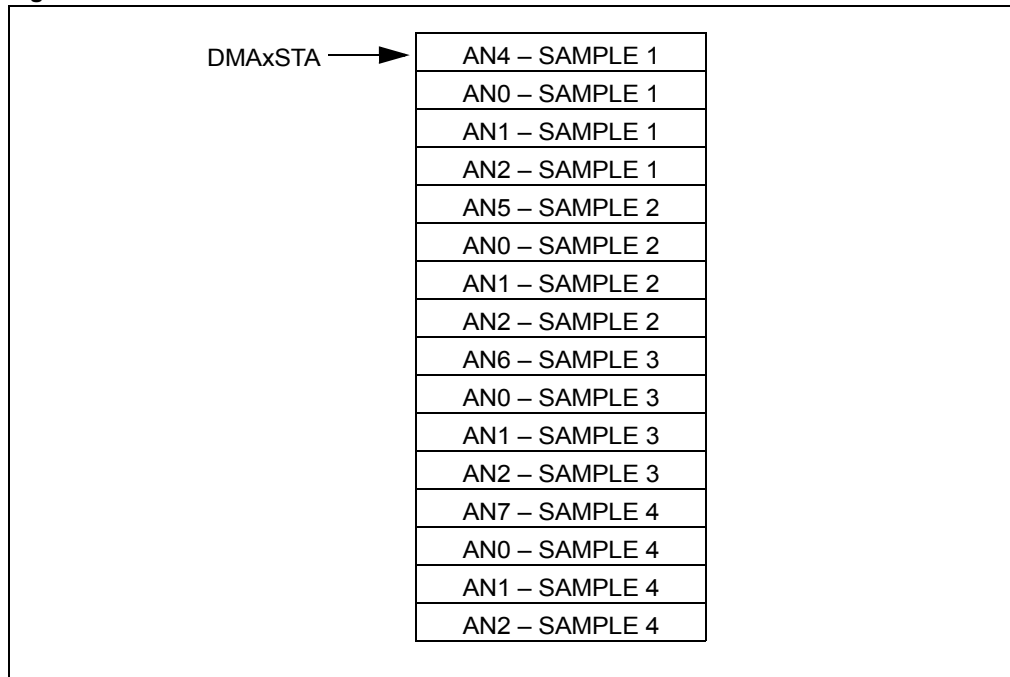

## 16.14 CONVERSION SEQUENCE EXAMPLES

The following configuration examples show the A/D operation in different sampling and buffering configurations. In each example, setting the ASAM bit starts automatic sampling. A conversion trigger ends sampling and starts conversion.

### 16.14.1 Sampling and Converting a Single Channel Multiple Times

Figure 16-17 and Table 16-2 illustrate a basic configuration of the ADC. In this case, one ADC input, AN0, is sampled by one Sample/Hold channel, CH0, and converted. The results are stored in the user-configured DMA buffer, illustrated as Buffer(0) through Buffer(15). This process repeats 16 times until the buffer is full and then the ADC module generates an interrupt. The entire process then repeats.

The CHPS bits specify that only Sample/Hold CH0 is active. With ALTS clear, only the MUX A inputs are active. The CH0SA bits and CH0NA bit are specified (AN0-VREF-) as the input to the Sample/Hold channel. All other input selection bits are not used.

**Figure 16-17: Converting One Channel 16 Times/Interrupt**

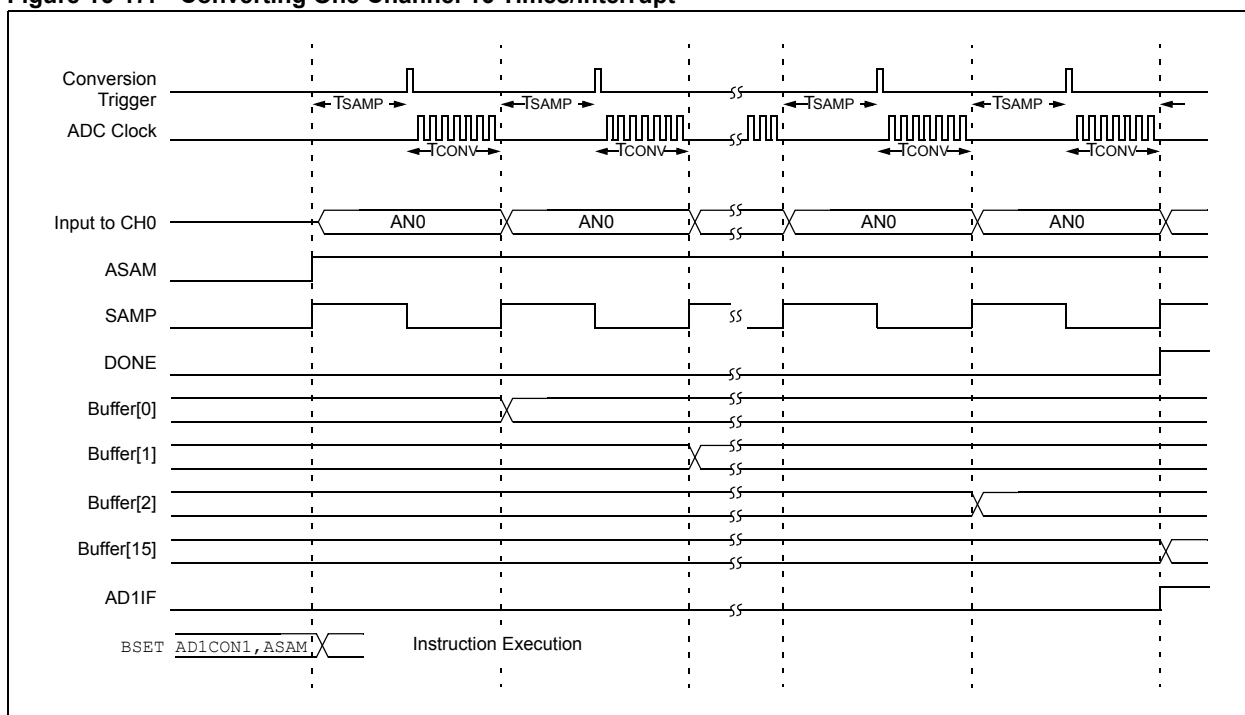

# PIC24H Family Reference Manual

**Table 16-2: Converting One Channel 16 Times per DMA Interrupt**

<b>CONTROL BITS</b>	<b>OPERATION SEQUENCE</b>
<b>Sequence Select</b>	
SMPI<3:0> = 0000, AMODE = 00, DMAxCNT = 15 DMA Interrupt on 16th conversion	Sample MUX A Inputs: AN0 -> CH0, convert CH0, write ADC1BUF0 and generate DMA Request
CHPS<1:0> = 00 Sample Channel CH0	Sample MUX A Inputs: AN0 -> CH0, convert CH0, write ADC1BUF0 and Generate DMA Request
SIMSAM = n/a Not applicable for single channel sample	Sample MUX A Inputs: AN0 -> CH0, convert CH0, write ADC1BUF0 and generate DMA Request
BUFM = 0 Single 16-word result buffer	Sample MUX A Inputs: AN0 -> CH0, convert CH0, write ADC1BUF0 and generate DMA Request
ALTS = 0 Always use MUX A input select	Sample MUX A Inputs: AN0 -> CH0, convert CH0, write ADC1BUF0 and generate DMA Request
<b>MUX A Input Select</b>	Sample MUX A Inputs: AN0 -> CH0, convert CH0, write ADC1BUF0 and generate DMA Request
CH0SA<4:0> = 00000 Select AN0 for CH0+ input	Sample MUX A Inputs: AN0 -> CH0, convert CH0, write ADC1BUF0 and generate DMA Request
CH0NA = 0 Select VREF- for CH0- input	Sample MUX A Inputs: AN0 -> CH0, convert CH0, write ADC1BUF0 and generate DMA Request
CSCNA = 0 No input scan	Sample MUX A Inputs: AN0 -> CH0, convert CH0, write ADC1BUF0 and generate DMA Request
CSSL<15:0> = n/a Scan input select unused	Sample MUX A Inputs: AN0 -> CH0, convert CH0, write ADC1BUF0 and generate DMA Request
CH123SA = n/a Channel CH1, CH2, CH3 + input unused	Sample MUX A Inputs: AN0 -> CH0, convert CH0, write ADC1BUF0 and generate DMA Request
CH123NA<1:0> = n/a Channel CH1, CH2, CH3 - input unused	Sample MUX A Inputs: AN0 -> CH0, convert CH0, write ADC1BUF0 and generate DMA Request
<b>MUX B Input Select</b>	Sample MUX A Inputs: AN0 -> CH0, convert CH0, write ADC1BUF0 and generate DMA Request
CH0SB<4:0> = n/a Channel CH0+ input unused	Sample MUX A Inputs: AN0 -> CH0, convert CH0, write ADC1BUF0 and generate DMA Request
CH0NB = n/a Channel CH0- input unused	Sample MUX A Inputs: AN0 -> CH0, convert CH0, write ADC1BUF0 and generate DMA Request
CH123SB = n/a Channel CH1, CH2, CH3 + input unused	Sample MUX A Inputs: AN0 -> CH0, convert CH0, write ADC1BUF0 and generate DMA Request
CH123NB<1:0> = n/a Channel CH1, CH2, CH3 - input unused	Sample MUX A Inputs: AN0 -> CH0, Convert CH0, write ADC1BUF0 and generate DMA Request
	DMA Interrupt
	<b>Repeat</b>

**DMA Buffer @  
1st DMA Interrupt**

AN0 Sample 1
AN0 Sample 2
AN0 Sample 3
AN0 Sample 4
AN0 Sample 5
AN0 Sample 6
AN0 Sample 7
AN0 Sample 8
AN0 Sample 9
AN0 Sample 10
AN0 Sample 11
AN0 Sample 12
AN0 Sample 13
AN0 Sample 14
AN0 Sample 15
AN0 Sample 16

**DMA Buffer @  
2nd DMA Interrupt**

AN0 Sample 17
AN0 Sample 18
AN0 Sample 19
AN0 Sample 20
AN0 Sample 21
AN0 Sample 22
AN0 Sample 23
AN0 Sample 24
AN0 Sample 25
AN0 Sample 26
AN0 Sample 27
AN0 Sample 28
AN0 Sample 29
AN0 Sample 30
AN0 Sample 31
AN0 Sample 32

## 16.14.2 A/D Conversions While Scanning Through All Analog Inputs

Figure 16-18 and Table 16-3 illustrate a typical setup where all available analog input channels are sampled by one Sample/Hold channel, CH0, and converted. The set Scan Input Selection (CSCNA) bit (ADxCON2<10>) specifies scanning of the ADC inputs to the CH0 positive input. Other conditions are similar to those described in **Section 16.14.1 “Sampling and Converting a Single Channel Multiple Times”**.

Initially, the AN0 input is sampled by CH0 and converted. The result is stored in the user-configured DMA buffer. Then the AN1 input is sampled and converted. This process of scanning the inputs repeats 16 times until the buffer is full. Then the ADC module generates an interrupt. The entire process then repeats.

**Figure 16-18: Scanning Through 16 Inputs/Interrupt**

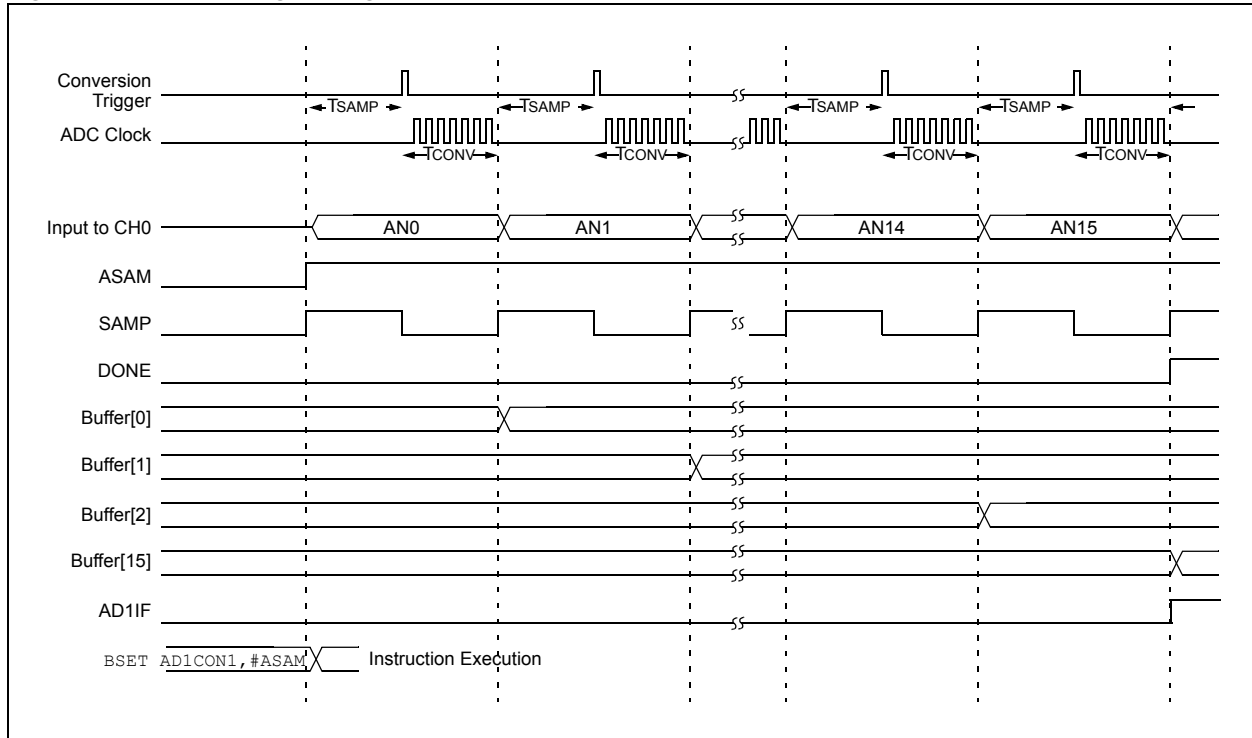

# PIC24H Family Reference Manual

**Table 16-3: Scanning Through 16 Inputs per DMA Interrupt**

CONTROL BITS	OPERATION SEQUENCE
<b>Sequence Select</b>	
SMPI<3:0> = 1111, AMODE = 00, DMAxCNT = 15 DMA Interrupt on 16th conversion	Sample MUX A Inputs: AN0 -> CH0, convert CH0, write ADC1BUF0, and generate DMA Request
CHPS<1:0> = 00 Sample Channel CH0	Sample MUX A Inputs: AN1 -> CH0, convert CH0, write ADC1BUF0, and generate DMA Request
SIMSAM = n/a Not applicable for single channel sample	Sample MUX A Inputs: AN2 -> CH0, convert CH0, write ADC1BUF0, and generate DMA Request
BUFM = 0 Single 16-word result buffer	Sample MUX A Inputs: AN3 -> CH0, convert CH0, write ADC1BUF0, and generate DMA Request
ALTS = 0 Always use MUX A input select	Sample MUX A Inputs: AN4 -> CH0, convert CH0, write ADC1BUF0, and generate DMA Request
<b>MUX A Input Select</b>	Sample MUX A Inputs: AN5 -> CH0, convert CH0, write ADC1BUF0, and generate DMA Request
CH0SA<4:0> = n/a Override by CSCNA	Sample MUX A Inputs: AN6 -> CH0, convert CH0, write ADC1BUF0, and generate DMA Request
CH0NA = 0 Select VREF- for CH0- input	Sample MUX A Inputs: AN7 -> CH0, convert CH0, write ADC1BUF0, and generate DMA Request
CSCNA = 1 Scan CH0+ Inputs	Sample MUX A Inputs: AN8 -> CH0, convert CH0, write ADC1BUF0, and generate DMA Request
CSSL<15:0> = 1111 1111 1111 1111 16 inputs scanned	Sample MUX A Inputs: AN9 -> CH0, convert CH0, write ADC1BUF0, and generate DMA Request
CH123SA = n/a Channel CH1, CH2, CH3 + input unused	Sample MUX A Inputs: AN10 -> CH0, convert CH0, write ADC1BUF0, and generate DMA Request
CH123NA<1:0> = n/a Channel CH1, CH2, CH3 - input unused	Sample MUX A Inputs: AN11 -> CH0, convert CH0, write ADC1BUF0, and generate DMA Request
<b>MUX B Input Select</b>	Sample MUX A Inputs: AN12 -> CH0, convert CH0, write ADC1BUF0, and generate DMA Request
CH0SB<3:0> = n/a Channel CH0+ input unused	Sample MUX A Inputs: AN13 -> CH0, convert CH0, write ADC1BUF0, and generate DMA Request
CH0NB = n/a Channel CH0- input unused	Sample MUX A Inputs: AN14 -> CH0, convert CH0, write ADC1BUF0, and generate DMA Request
CH123SB = n/a Channel CH1, CH2, CH3 + input unused	Sample MUX A Inputs: AN15 -> CH0, convert CH0, write ADC1BUF0, and generate DMA Request
CH123NB<1:0> = n/a Channel CH1, CH2, CH3 - input unused	Interrupt
	<b>Repeat</b>

**DMA Buffer @  
1st DMA Interrupt**

AN0 Sample 1
AN1 Sample 2
AN2 Sample 3
AN3 Sample 4
AN4 Sample 5
AN5 Sample 6
AN6 Sample 7
AN7 Sample 8
AN8 Sample 9
AN9 Sample 10
AN10 Sample 11
AN11 Sample 12
AN12 Sample 13
AN13 Sample 14
AN14 Sample 15
AN15 Sample 16

**DMA Buffer @  
2nd DMA Interrupt**

AN0 Sample 17
AN1 Sample 18
AN2 Sample 19
AN3 Sample 20
AN4 Sample 21
AN5 Sample 22
AN6 Sample 23
AN7 Sample 24
AN8 Sample 25
AN9 Sample 26
AN10 Sample 27
AN11 Sample 28
AN12 Sample 29
AN13 Sample 30
AN14 Sample 31
AN15 Sample 32



## 16.14.3 Sampling Three Inputs Frequently While Scanning Four Other Inputs

Figure 16-19 and Table 16-4 show how the ADC module could be configured to sample three inputs frequently using Sample/Hold channels CH1, CH2 and CH3; while four other inputs are sampled less frequently by scanning them using Sample/Hold channel CH0. In this case, only MUX A inputs are used, and all four channels are sampled simultaneously. Four different inputs (AN4, AN5, AN6, AN7) are scanned in CH0, whereas AN0, AN1 and AN2 are the fixed inputs for CH1, CH2 and CH3, respectively. Thus, in every set of 16 samples, AN0, AN1 and AN2 are sampled four times, while AN4, AN5, AN6 and AN7 are sampled only once each.

**Figure 16-19: Converting Three Inputs, Four Times and Four Inputs, One Time/Interrupt**

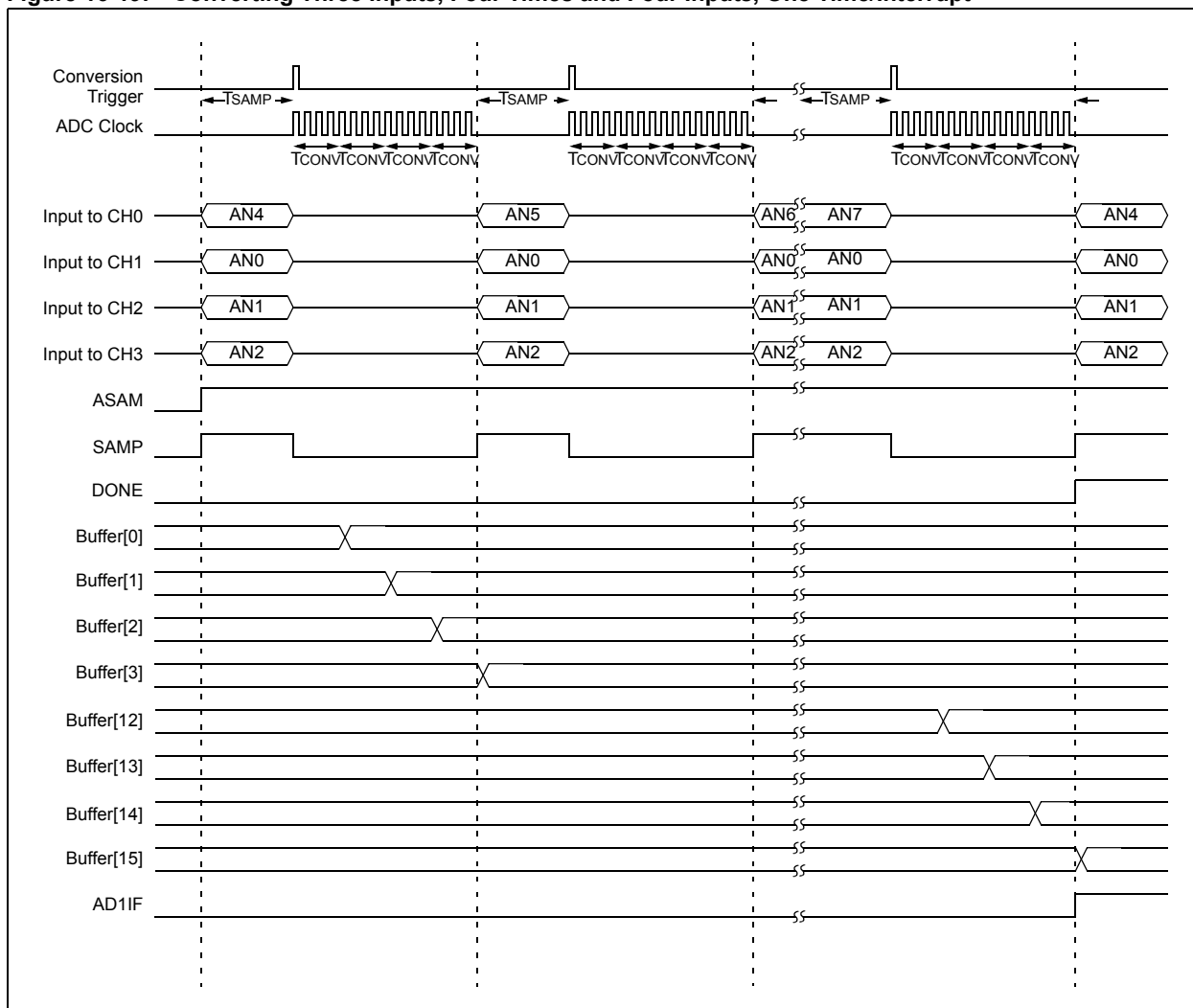

# PIC24H Family Reference Manual

**Table 16-4: Converting Three Inputs, Four Times and Four Inputs, One Time per DMA Interrupt**

CONTROL BITS	OPERATION SEQUENCE
<b>Sequence Select</b>	
SMPI<3:0> = 0011, AMODE = 00, DMAxCNT = 15 Scan 4 inputs, Interrupt on 16th conversion	Sample MUX A Inputs: AN4 -> CH0, AN0 -> CH1, AN1 -> CH2, AN2 -> CH3 Convert CH0, write ADC1BUF0, and generate DMA Request Convert CH1, write ADC1BUF0, and generate DMA Request Convert CH2, write ADC1BUF0, and generate DMA Request Convert CH3, write ADC1BUF0, and generate DMA Request
CHPS<1:0> = 1x Sample Channels CH0, CH1, CH2, CH3	Sample MUX A Inputs: AN5 -> CH0, AN0 -> CH1, AN1 -> CH2, AN2 -> CH3 Convert CH0, write ADC1BUF0, and generate DMA Request Convert CH1, write ADC1BUF0, and generate DMA Request Convert CH2, write ADC1BUF0, and generate DMA Request Convert CH3, write ADC1BUF0, and generate DMA Request
SIMSAM = 1 Sample all channels simultaneously	Sample MUX A Inputs: AN6 -> CH0, AN0 -> CH1, AN1 -> CH2, AN2 -> CH3 Convert CH0, write ADC1BUF0, and generate DMA Request Convert CH1, write ADC1BUF0, and generate DMA Request Convert CH2, write ADC1BUF0, and generate DMA Request Convert CH3, write ADC1BUF0, and generate DMA Request
BUFM = 0 Single 16-word result buffer	Sample MUX A Inputs: AN7 -> CH0, AN0 -> CH1, AN1 -> CH2, AN2 -> CH3 Convert CH0, write ADC1BUF0, and generate DMA Request Convert CH1, write ADC1BUF0, and generate DMA Request Convert CH2, write ADC1BUF0, and generate DMA Request Convert CH3, write ADC1BUF0, and generate DMA Request
ALTS = 0 Always use MUX A input select	Interrupt
<b>MUX A Input Select</b>	<b>Repeat</b>
CHOSA<3:0> = n/a Override by CSCNA	
CH0NA = 0 Select VREF- for CH0- input	
CSCNA = 1 Scan CH0+ Inputs	
CSSL<15:0> = 0000 0000 1111 0000 Scan AN4, AN5, AN6, AN7	
CH123SA = 0 CH1+ = AN0, CH2+ = AN1, CH3+ = AN2	
CH123NA<1:0> = 0x CH1-, CH2-, CH3- = VREF-	
<b>MUX B Input Select</b>	
CH0SB<3:0> = n/a Channel CH0+ input unused	
CH0NB = n/a Channel CH0- input unused	
CH123SB = n/a Channel CH1, CH2, CH3 + input unused	
CH123NB<1:0> = n/a Channel CH1, CH2, CH3 - input unused	

**DMA Buffer @  
1st DMA Interrupt**

AN4 Sample 1
AN0 Sample 1
AN1 Sample 1
AN2 Sample 1
AN5 Sample 1
AN0 Sample 2
AN1 Sample 2
AN2 Sample 2
AN6 Sample 1
AN0 Sample 3
AN1 Sample 3
AN2 Sample 3
AN7 Sample 1
AN0 Sample 4
AN1 Sample 4
AN2 Sample 4

**DMA Buffer @  
2nd DMA Interrupt**

AN4 Sample 2
AN0 Sample 5
AN1 Sample 5
AN2 Sample 5
AN5 Sample 2
AN0 Sample 6
AN1 Sample 6
AN2 Sample 6
AN6 Sample 2
AN0 Sample 7
AN1 Sample 7
AN2 Sample 7
AN7 Sample 2
AN0 Sample 8
AN1 Sample 8
AN2 Sample 8

## 16.14.4 Using Alternating MUX A, MUX B Input Selections

Figure 16-20 and Table 16-5 demonstrate alternate sampling of the inputs assigned to MUX A and MUX B. In this example, two channels are enabled to sample simultaneously. Setting the ALTS bit (ADCxCON2<0>) enables alternating input selections. The first sample uses the MUX A inputs specified by the CH0SA, CH0NA, CH123SA and CH123NA bits. The next sample uses the MUX B inputs specified by the CH0SB, CH0NB, CH123SB and CH123NB bits. In this example, one of the MUX B input specifications uses two analog inputs as a differential source to the Sample/Hold, sampling (AN3-AN9).

Note that using four Sample/Hold channels without alternating input selections results in the same number of conversions as this example, using two channels with alternating input selections. However, because the CH1, CH2 and CH3 channels are more limited in the selectivity of the analog inputs, this example method provides more flexibility of input selection than using four channels.

**Figure 16-20: Converting Two Sets of Two Inputs Using Alternating Input Selections**

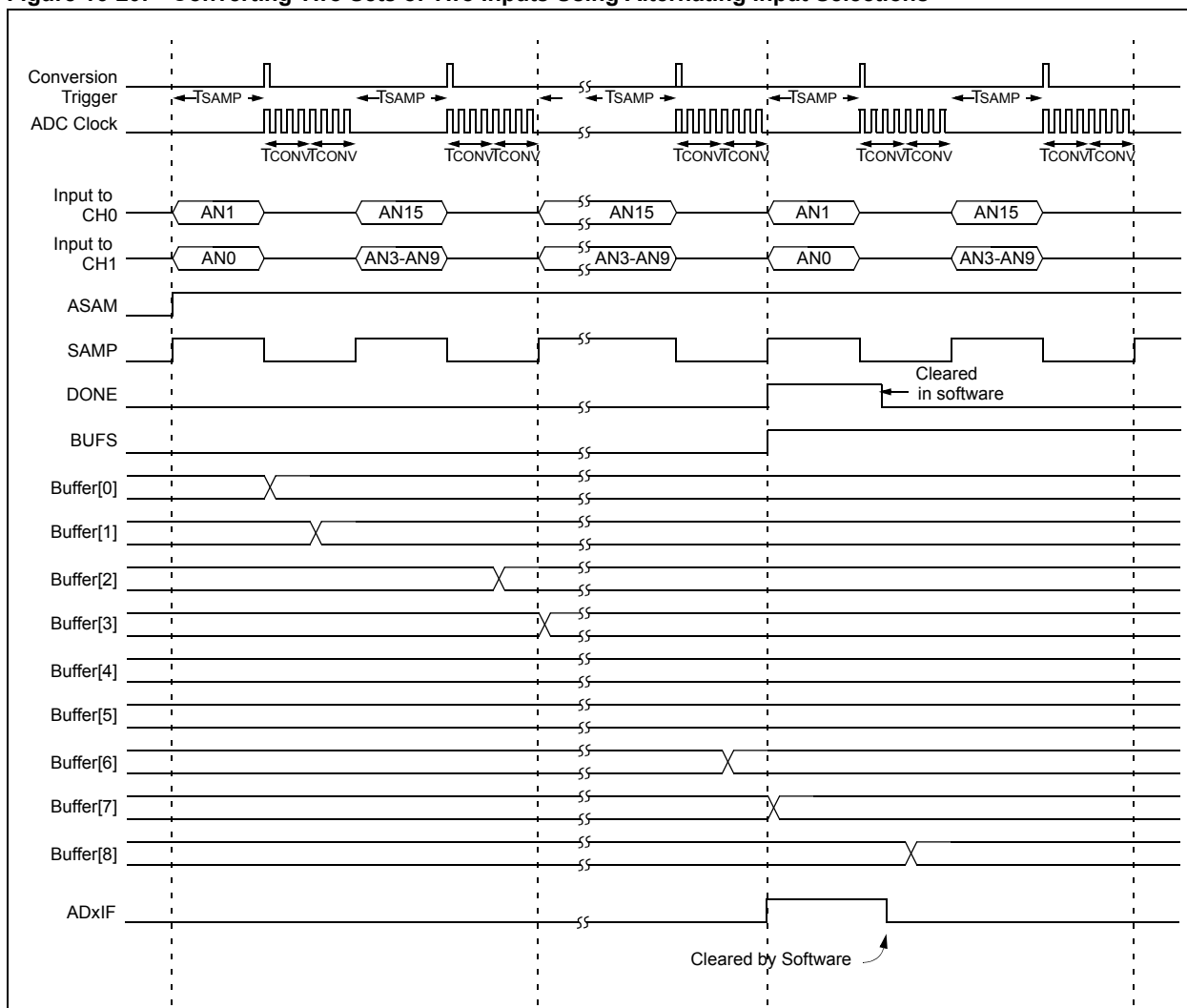

# PIC24H Family Reference Manual

**Table 16-5: Converting Two Sets of Two Inputs Using Alternating Input Selections**

<b>CONTROL BITS</b>	<b>OPERATION SEQUENCE</b>
<b>Sequence Select</b>	
SMPI<3:0> = 0001, AMODE = 00, DMAxCNT = 7 Alt. Sampling, DMA Interrupt on 8th conversion	Sample MUX A Inputs: AN1 -> CH0, AN0 -> CH1 Convert CH0, write ADC1BUF0, and generate DMA Request Convert CH1, write ADC1BUF0, and generate DMA Request
CHPS<1:0> = 01 Sample Channels CH0, CH1	Sample MUX B Inputs: AN15 -> CH0, (AN3-AN9) -> CH1 Convert CH0, write ADC1BUF0, and generate DMA Request Convert CH1, write ADC1BUF0, and generate DMA Request
SIMSAM = 1 Sample all channels simultaneously	Sample MUX A Inputs: AN1 -> CH0, AN0 -> CH1 Convert CH0, write ADC1BUF0, and generate DMA Request Convert CH1, write ADC1BUF0, and generate DMA Request
BUFM = 1 Dual 8-word result buffers	Sample MUX B Inputs: AN15 -> CH0, (AN3-AN9) -> CH1 Convert CH0, write ADC1BUF0, and generate DMA Request Convert CH1, write ADC1BUF0, and generate DMA Request
ALTS = 1 Alternate MUX A/B input select	Interrupt
<b>MUX A Input Select</b>	<b>Repeat</b>
CH0SA<3:0> = 0001 Select AN1 for CH0+ input	
CH0NA = 0 Select VREF- for CH0- input	
CSCNA = 0 No input scan	
CSSL<15:0> = n/a Scan input select unused	
CH123SA = 0 CH1+ = AN0, CH2+ = AN1, CH3+ = AN2	
CH123NA<1:0> = 0x CH1-, CH2-, CH3- = VREF-	
<b>MUX B Input Select</b>	
CH0SB<3:0> = 1111 Select AN15 for CH0+ input	
CH0NB = 0 Select VREF- for CH0- input	
CH123SB = 1 CH1+ = AN3, CH2+ = AN4, CH3+ = AN5	
CH123NB<1:0> = 11 CH1- = AN9, CH2- = AN10, CH3- = AN11	

**DMA Buffer @  
1st DMA Interrupt**

AN1 Sample 1
AN0 Sample 1
AN15 Sample 1
(AN3-AN9) Sample 1
AN1 Sample 2
AN0 Sample 2
AN15 Sample 2
(AN3-AN9) Sample 2

**DMA Buffer @  
2nd DMA Interrupt**

AN1 Sample 3
AN0 Sample 3
AN15 Sample 3
(AN3-AN9) Sample 3
AN1 Sample 4
AN0 Sample 4
AN15 Sample 4
(AN3-AN9) Sample 4

## 16.14.5 Sampling Eight Inputs Using Simultaneous Sampling

This and the next example demonstrate identical setups with the exception that this example uses simultaneous sampling ( $SIMSAM = 1$ ), and the following example uses sequential sampling ( $SIMSAM = 0$ ). Both examples use alternating inputs and specify differential inputs to the Sample/Hold.

Figure 16-21 and Table 16-6 demonstrate simultaneous sampling. When converting more than one channel and selecting simultaneous sampling, the ADC module samples all channels, then performs the required conversions in sequence. In this example, with ASAM set, sampling begins after the conversions complete.

**Figure 16-21: Sampling Eight Inputs Using Simultaneous Sampling**

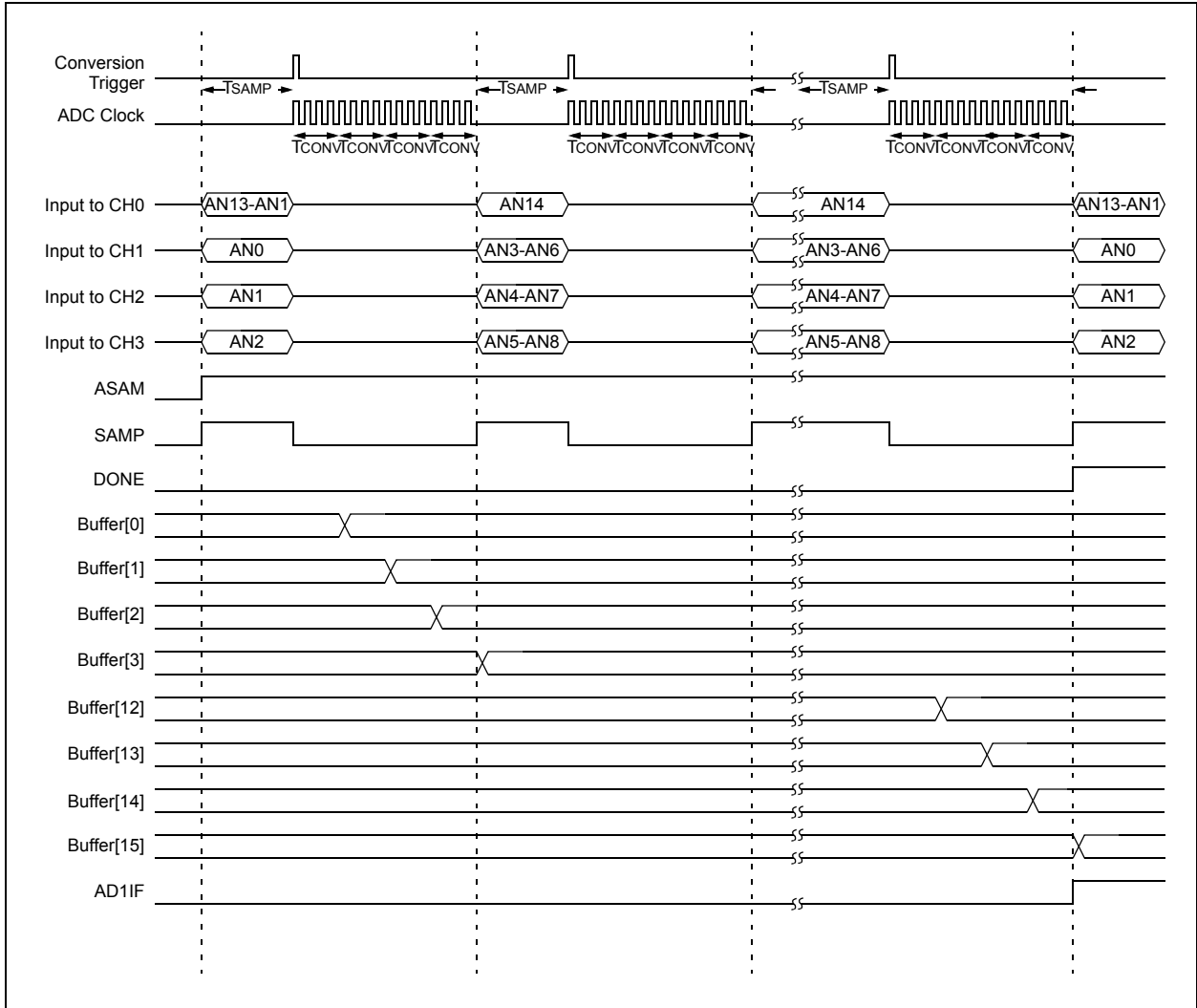

# PIC24H Family Reference Manual

**Table 16-6: Sampling Eight Inputs Using Simultaneous Sampling**

CONTROL BITS	OPERATION SEQUENCE
<b>Sequence Select</b>	
SMPI<3:0> = 0001, AMODE = 00, DMAxCNT = 15 Alt. sampling, DMA interrupt on 16th conversion	Sample MUX A Inputs: (AN13-AN1) -> CH0, AN0 -> CH1, AN1 -> CH2, AN2 -> CH3 Convert CH0, write ADC1BUF0, and generate DMA Request Convert CH1, write ADC1BUF0, and generate DMA Request Convert CH2, write ADC1BUF0, and generate DMA Request Convert CH3, write ADC1BUF0, and generate DMA Request
CHPS<1:0> = 1x Sample Channels CH0, CH1, CH2, CH3	Sample MUX B Inputs: AN14 -> CH0, (AN3-AN6) -> CH1, (AN4-AN7) -> CH2, (AN5-AN8) -> CH3 Convert CH0, write ADC1BUF0, and generate DMA Request Convert CH1, write ADC1BUF0, and generate DMA Request Convert CH2, write ADC1BUF0, and generate DMA Request Convert CH3, write ADC1BUF0, and generate DMA Request
SIMSAM = 1 Sample all channels simultaneously	Sample MUX A Inputs: (AN13-AN1) -> CH0, AN0 -> CH1, AN1 -> CH2, AN2 -> CH3 Convert CH0, write ADC1BUF0, and generate DMA Request Convert CH1, write ADC1BUF0, and generate DMA Request Convert CH2, write ADC1BUF0, and generate DMA Request Convert CH3, write ADC1BUF0, and generate DMA Request
BUFM = 0 Single 16-word result buffer	Sample MUX B Inputs: AN14 -> CH0, (AN3-AN6) -> CH1, (AN4-AN7) -> CH2, (AN5-AN8) -> CH3 Convert CH0, write ADC1BUF0, and generate DMA Request Convert CH1, write ADC1BUF0, and generate DMA Request Convert CH2, write ADC1BUF0, and generate DMA Request Convert CH3, write ADC1BUF0, and generate DMA Request
ALTS = 1 Alternate MUX A/MUX B input select	Interrupt
<b>MUX A Input Select</b>	<b>Repeat</b>
CH0SA<3:0> = 1101 Select AN13 for CH0+ input	
CH0NA = 1 Select AN1 for CH0- input	
CSCNA = 0 No input scan	
CSSL<15:0> = n/a Scan input select unused	
CH123SA = 0 CH1+ = AN0, CH2+ = AN1, CH3+ = AN2	
CH123NA<1:0> = 0x CH1-, CH2-, CH3- = VREF-	
<b>MUX B Input Select</b>	
CH0SB<3:0> = 1110 Select AN14 for CH0+ input	
CH0NB = 0 Select VREF- for CH0- input	
CH123SB = 1 CH1+ = AN3, CH2+ = AN4, CH3+ = AN5	
CH123NB<1:0> = 10 CH1- = AN6, CH2- = AN7, CH3- = AN8	

**DMA Buffer @  
1st DMA Interrupt**

(AN13-AN1) Sample 1
AN0 Sample 1
AN1 Sample 1
AN2 Sample 1
AN14 Sample 1
(AN3-AN6) Sample 1
(AN4-AN7) Sample 1
(AN5-AN8) Sample 1
(AN13-AN1) Sample 1
AN0 Sample 2
AN1 Sample 2
AN2 Sample 2
AN14 Sample 2
(AN3-AN6) Sample 2
(AN4-AN7) Sample 2
(AN5-AN8) Sample 2

**DMA Buffer @  
2nd DMA Interrupt**

(AN13-AN1) Sample 3
AN0 Sample 3
AN1 Sample 3
AN2 Sample 3
AN14 Sample 3
(AN3-AN6) Sample 3
(AN4-AN7) Sample 3
(AN5-AN8) Sample 3
(AN13-AN1) Sample 4
AN0 Sample 4
AN1 Sample 4
AN2 Sample 4
AN14 Sample 4
(AN3-AN6) Sample 4
(AN4-AN7) Sample 4
(AN5-AN8) Sample 4

## 16.14.6 Sampling Eight Inputs Using Sequential Sampling

Figure 16-22 and Table 16-7 demonstrate sequential sampling. When converting more than one channel and selecting sequential sampling, the ADC module starts sampling a channel at the earliest opportunity, then performs the required conversions in sequence. In this example, with ASAM set, sampling of a channel begins after the conversion of that channel completes.

When ASAM is clear, sampling does not resume after conversion completion but occurs when the SAMP bit is set.

When utilizing more than one channel, sequential sampling provides more sampling time since a channel can be sampled while conversion occurs on another.

**Figure 16-22: Sampling Eight Inputs Using Sequential Sampling**

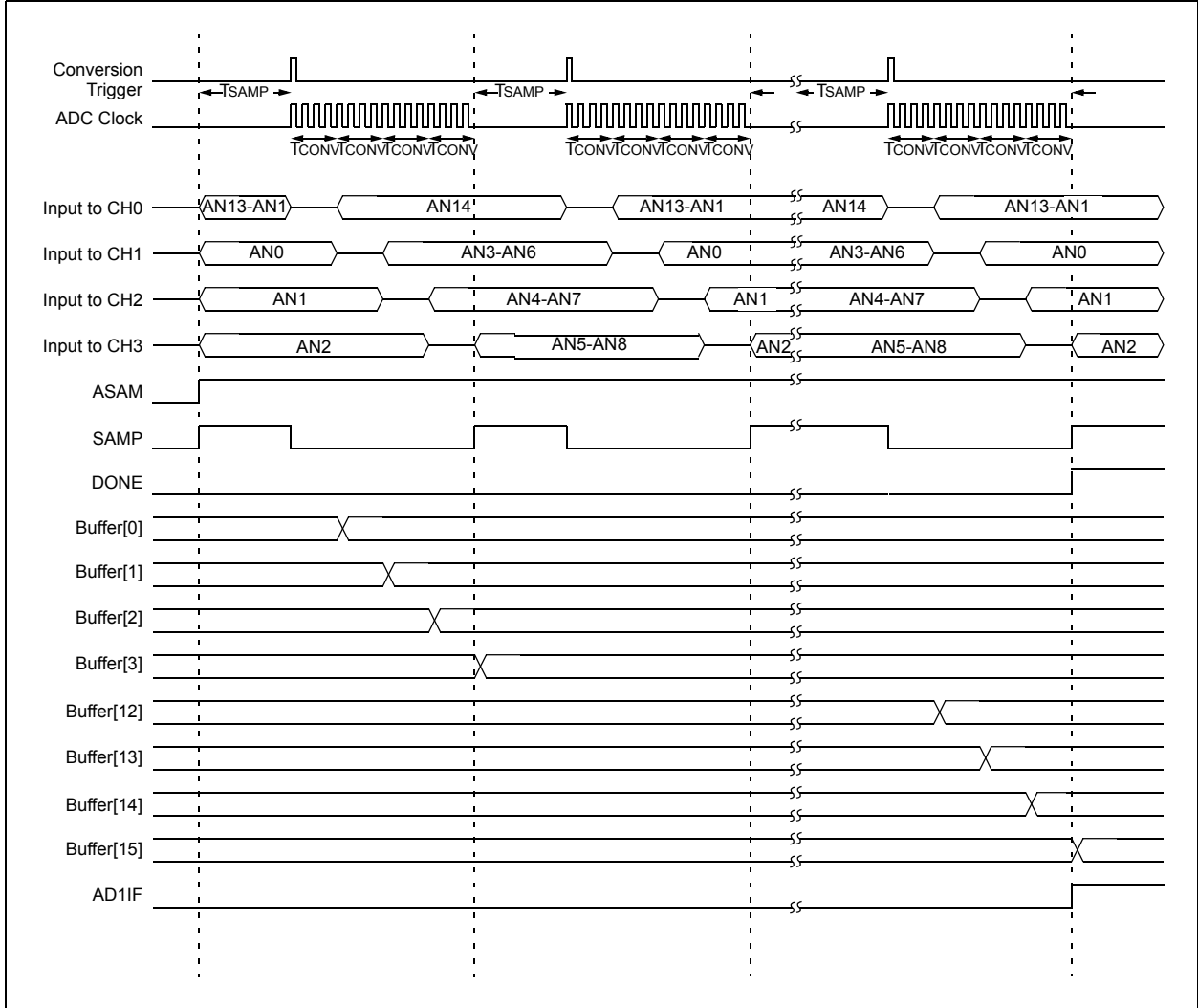

# PIC24H Family Reference Manual

**Table 16-7: Sampling Eight Inputs Using Sequential Sampling**

CONTROL BITS	OPERATION SEQUENCE
<b>Sequence Select</b>	
SMPI<3:0> = 0001, AMODE = 00, DMAxCNT = 15 Alt. sampling, DMA interrupt on 16th sample	Sample: (AN13-AN1) -> CH0, convert CH0, write ADC1BUF0, and generate DMA Request
CHPS<1:0> = 1x Sample Channels CH0, CH1, CH2, CH3	Sample: AN0 -> CH1, convert CH0, write ADC1BUF0, and generate DMA Request
SIMSAM = 0 Sample all channels sequentially	Sample: AN1 -> CH2, convert CH0, write ADC1BUF0, and generate DMA Request
BUFM = 0 Single 16-word result buffer	Sample: AN2 -> CH3, convert CH0, write ADC1BUF0, and generate DMA Request
ALTS = 1 Alternate MUX A/B input select	Sample: AN14 -> CH0, convert CH0, write ADC1BUF0, and generate DMA Request
<b>MUX A Input Select</b>	Sample: (AN3-AN6) -> CH1, convert CH0, write ADC1BUF0, and generate DMA Request
CH0SA<3:0> = 0110 Select AN6 for CH0+ input	Sample: (AN4-AN7) -> CH2, convert CH0, write ADC1BUF0, and generate DMA Request
CH0NA = 0 Select VREF- for CH0- input	Sample: (AN5-AN8) -> CH3, convert CH0, write ADC1BUF0, and generate DMA Request
CSCNA = 0 No input scan	Sample: (AN13-AN1) -> CH0, convert CH0, write ADC1BUF0, and generate DMA Request
CSSL<15:0> = n/a Scan input select unused	Sample: AN0 -> CH1, convert CH0, write ADC1BUF0, and generate DMA Request
CH123SA = 0 CH1+ = AN0, CH2+ = AN1, CH3+ = AN2	Sample: AN1 -> CH2, convert CH0, write ADC1BUF0, and generate DMA Request
CH123NA<1:0> = 0x CH1-, CH2-, CH3- = VREF-	Sample: AN2 -> CH3, convert CH0, write ADC1BUF0, and generate DMA Request
<b>MUX B Input Select</b>	Sample: AN14 -> CH0, convert CH0, write ADC1BUF0, and generate DMA Request
CH0SB<3:0> = 0111 Select AN7 for CH0+ input	Sample: (AN3-AN6) -> CH1, convert CH0, write ADC1BUF0, and generate DMA Request
CH0NB = 0 Select VREF- for CH0- input	Sample: (AN4-AN7) -> CH2, convert CH0, write ADC1BUF0, and generate DMA Request
CH123SB = 1 CH1+ = AN3, CH2+ = AN4, CH3+ = AN5	Sample: (AN5-AN8) -> CH3, convert CH0, write ADC1BUF0, and generate DMA Request
CH123NB<1:0> = 0x CH1-, CH2-, CH3- = VREF-	Interrupt
	<b>Repeat</b>

**DMA Buffer @  
1st DMA Interrupt**

(AN13-AN1) Sample 1
AN0 Sample 1
AN1 Sample 1
AN2 Sample 1
AN14 Sample 1
(AN3-AN6) Sample 1
(AN4-AN7) Sample 1
(AN5-AN8) Sample 1
(AN13-AN1) Sample 2
AN0 Sample 2
AN1 Sample 2
AN2 Sample 2
AN14 Sample 2
(AN3-AN6) Sample 2
(AN4-AN7) Sample 2
(AN5-AN8) Sample 2

**DMA Buffer @  
2nd DMA Interrupt**

(AN13-AN1) Sample 3
AN0 Sample 3
AN1 Sample 3
AN2 Sample 3
AN14 Sample 3
(AN3-AN6) Sample 3
(AN4-AN7) Sample 3
(AN5-AN8) Sample 3
(AN13-AN1) Sample 4
AN0 Sample 4
AN1 Sample 4
AN2 Sample 28
AN14 Sample 4
(AN3-AN6) Sample 4
(AN4-AN7) Sample 4
(AN5-AN8) Sample 4



## 16.15 A/D SAMPLING REQUIREMENTS

The analog input model of the 10-bit and 12-bit ADC modes are shown in Figure 16-23 and Figure 16-24. The total sampling time for the A/D conversion is a function of the internal amplifier settling time and the holding capacitor charge time.

For the ADC module to meet its specified accuracy, the charge holding capacitor (CHOLD) must be allowed to fully charge to the voltage level on the analog input pin. The analog output source impedance ( $R_s$ ), the interconnect impedance ( $R_{ic}$ ) and the internal sampling switch ( $R_{ss}$ ) impedance combine to directly affect the time required to charge the capacitor CHOLD. The combined impedance must, therefore, be small enough to fully charge the holding capacitor within the chosen sample time. To minimize the effects of pin leakage currents on the accuracy of the ADC module, the maximum recommended source impedance,  $R_s$ , is  $200\Omega$ . After the analog input channel is selected, this sampling function must be completed prior to starting the conversion. The internal holding capacitor will be in a discharged state prior to each sample operation.

A minimum time period should be allowed between conversions for the sample time. For more details about the minimum sampling time for a device, see the device electrical specifications.

**Figure 16-23: Analog Input Model (10-bit Mode)**

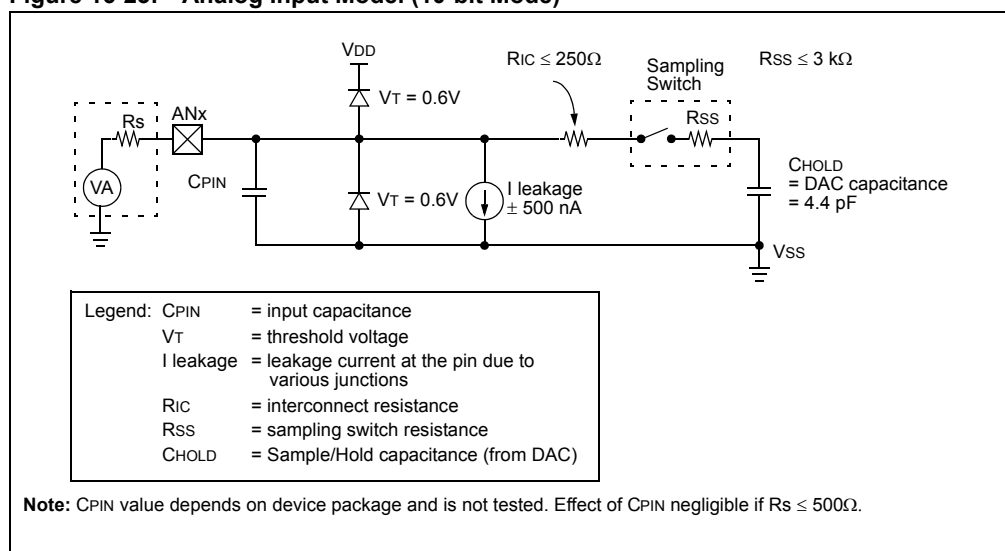

**Figure 16-24: Analog Input Model (12-bit Mode)**

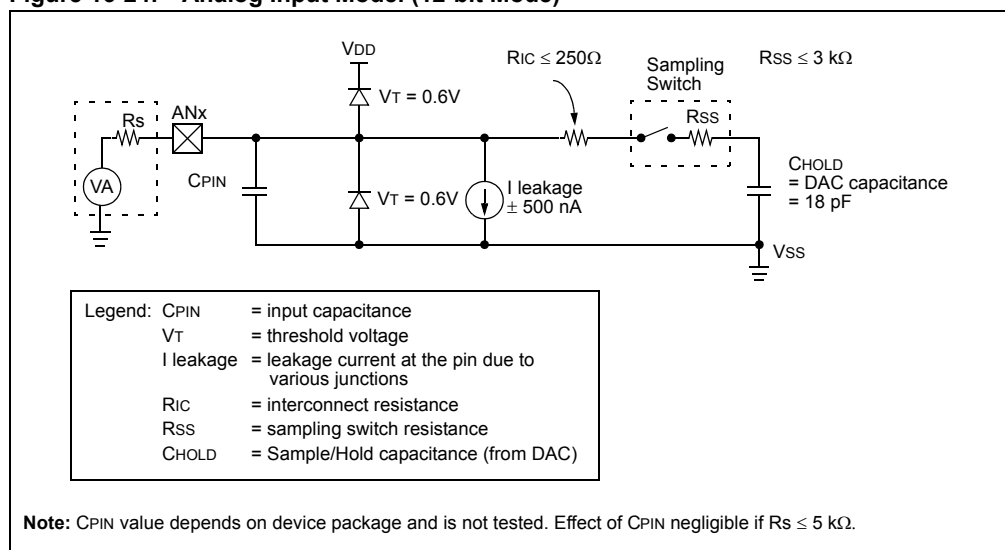

# PIC24H Family Reference Manual

## 16.16 READING THE ADC RESULT BUFFER

The RAM is 10-bits or 12-bits wide, but the data is automatically formatted to one of two selectable formats when the buffer is read. The FORM<1:0> bits (ADxCON1<9:8>) select the format. The formatting hardware provides a 16-bit result on the data bus for all of the data formats. Figure 16-25 and Figure 16-26 show the data output formats that can be selected using the FORM<1:0> control bits.

**Figure 16-25: A/D Output Data Formats (10-bit Mode)**

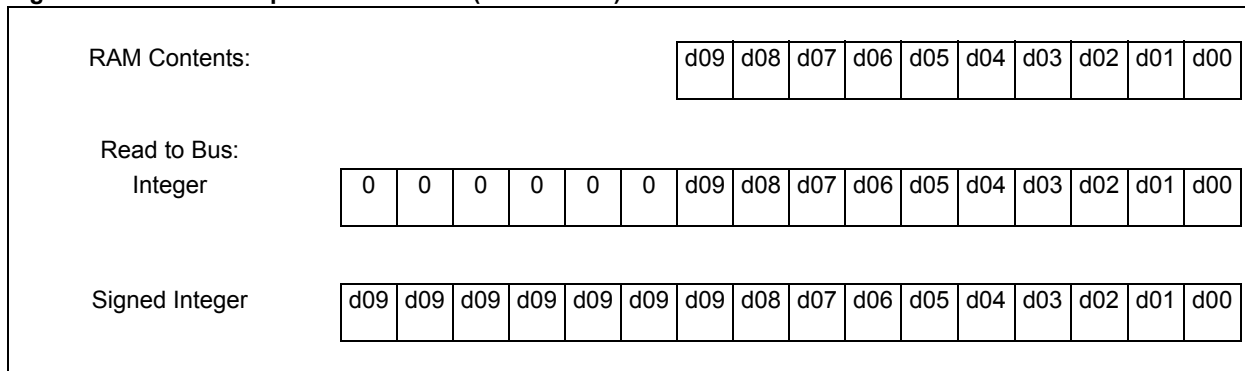

**Figure 16-26: A/D Output Data Formats (12-bit Mode)**

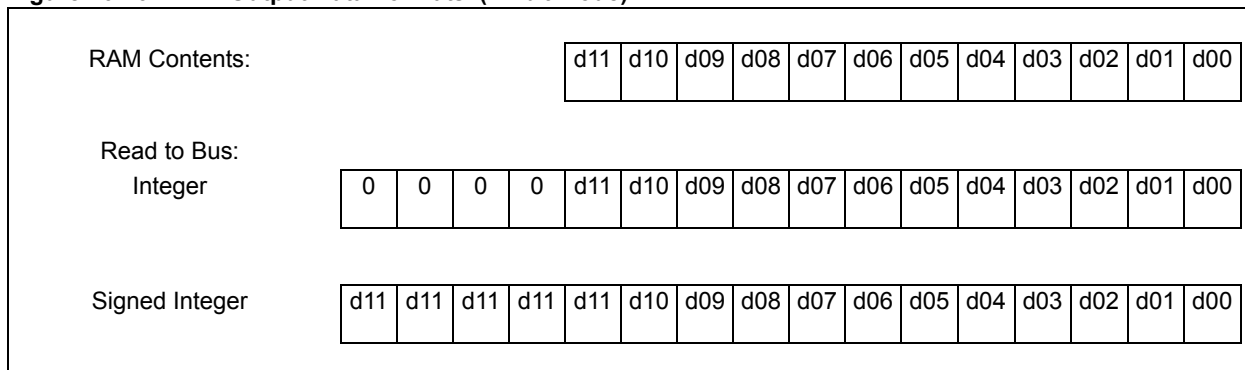

# Section 16. Analog-to-Digital Converter (ADC)

**Table 16-8: Numerical Equivalents of Various Result Codes (10-bit Mode)**

VIN/VREF	10-bit Output Code	16-bit Integer Format	16-bit Signed Integer Format
1023/1024	11 1111 1111	0000 0011 1111 1111 = 1023	0000 0001 1111 1111 = 511
1022/1024	11 1111 1110	0000 0011 1111 1110 = 1022	0000 0001 1111 1110 = 510
...			
513/1024	10 0000 0001	0000 0010 0000 0001 = 513	0000 0000 0000 0001 = 1
512/1024	10 0000 0000	0000 0010 0000 0000 = 512	0000 0000 0000 0000 = 0
511/1024	01 1111 1111	0000 0001 1111 1111 = 511	1111 1111 1111 1111 = -1
...			
1/1024	00 0000 0001	0000 0000 0000 0001 = 1	1111 1110 0000 0001 = -511
0/1024	00 0000 0000	0000 0000 0000 0000 = 0	1111 1110 0000 0000 = -512

**Table 16-9: Numerical Equivalents of Various Result Codes (12-bit Mode)**

VIN/VREF	12-bit Output Code	16-bit Unsigned Integer Format	16-bit Signed Integer Format
4095/4096	1111 1111 1111	0000 1111 1111 1111 = 4095	0000 0111 1111 1111 = 2047
4094/4096	1111 1111 1110	0000 1111 1111 1110 = 4094	0000 0111 1111 1110 = 2046
...			
2049/4096	1000 0000 0001	0000 1000 0000 0001 = 2049	0000 0000 0000 0001 = 1
2048/4096	1000 0000 0000	0000 1000 0000 0000 = 2048	0000 0000 0000 0000 = 0
2047/4096	0111 1111 1111	0000 0111 1111 1111 = 2047	1111 1111 1111 1111 = -1
...			
1/4096	0000 0000 0001	0000 0000 0000 0001 = 1	1111 1000 0000 0001 = -2047
0/4096	0000 0000 0000	0000 0000 0000 0000 = 0	1111 1000 0000 0000 = -2048

## 16.17 TRANSFER FUNCTION (10-BIT MODE)

The ideal transfer function of the ADC module is shown in Figure 16-27. The difference of the input voltages, ( $V_{INH} - V_{INL}$ ), is compared to the reference, ( $V_{REFH} - V_{REFL}$ ).

- The first code transition (A) occurs when the input voltage is ( $V_{REFH} - V_{REFL}/2048$ ) or 0.5 LSb.
- The 00 0000 0001 code is centered at ( $V_{REFH} - V_{REFL}/1024$ ) or 1.0 LSb (B).
- The 10 0000 0000 code is centered at ( $512 * (V_{REFH} - V_{REFL})/1024$ ) (C).
- An input voltage less than ( $1 * (V_{REFH} - V_{REFL})/2048$ ) converts as 00 0000 0000 (D).
- An input greater than ( $2045 * (V_{REFH} - V_{REFL})/2048$ ) converts as 11 1111 1111 (E).

Figure 16-27: ADC Module Transfer Function (10-bit Mode)

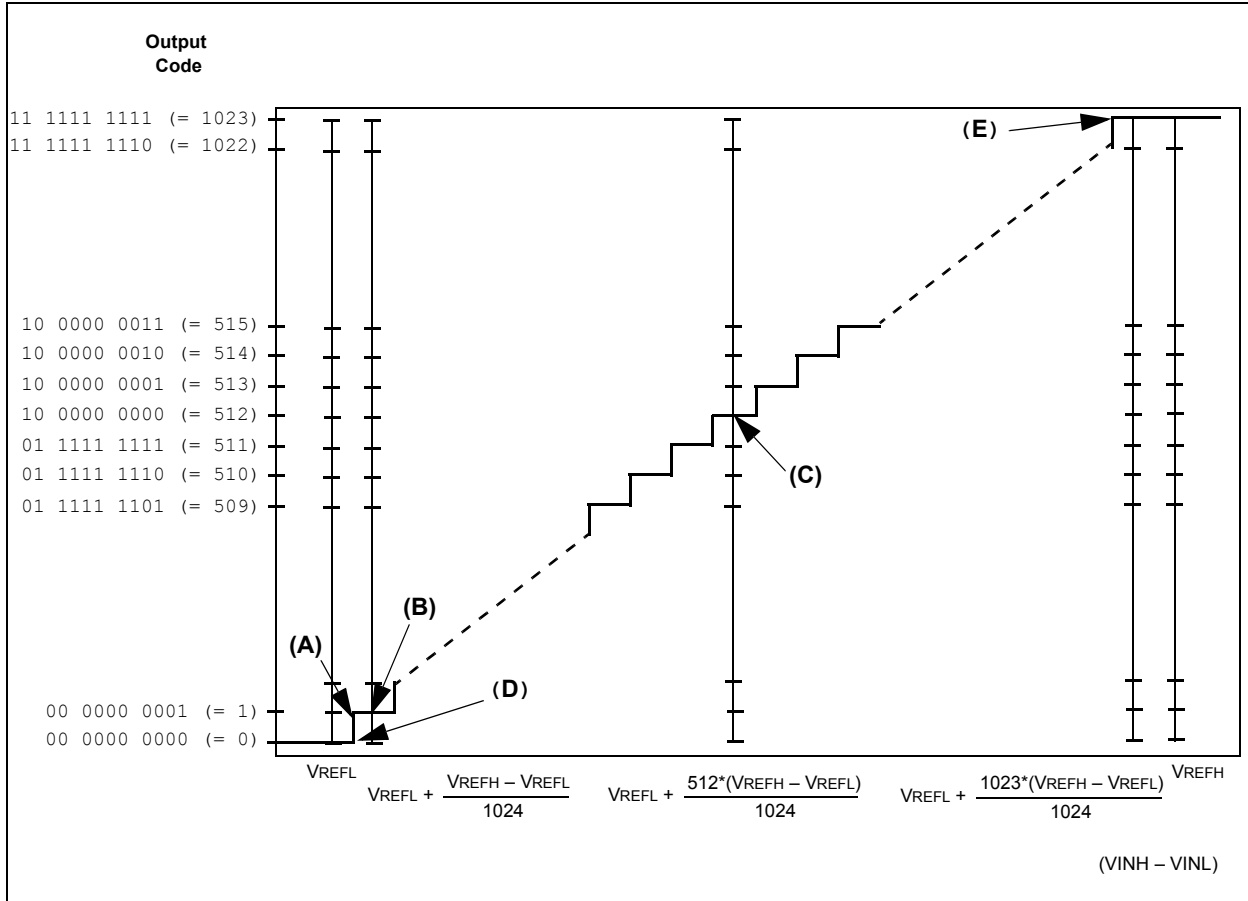

## 16.18 TRANSFER FUNCTION (12-BIT MODE)

The ideal transfer function of the ADC is shown in Figure 16-27. The difference of the input voltages ( $V_{INH} - V_{INL}$ ) is compared to the reference ( $V_{REFH} - V_{REFL}$ ).

- The first code transition (A) occurs when the input voltage is  $(V_{REFH} - V_{REFL}/8192)$  or 0.5 LSb.
- The 00 0000 0001 code is centered at  $(V_{REFH} - V_{REFL}/4096)$  or 1.0 LSb (B).
- The 10 0000 0000 code is centered at  $(2048*(V_{REFH} - V_{REFL})/4096)$  (C).
- An input voltage less than  $(1*(V_{REFH} - V_{REFL})/8192)$  converts as 00 0000 0000 (D).
- An input greater than  $(8192*(V_{REFH} - V_{REFL})/8192)$  converts as 11 1111 1111 (E).

**Figure 16-28: A/D Transfer Function (12-bit Mode)**

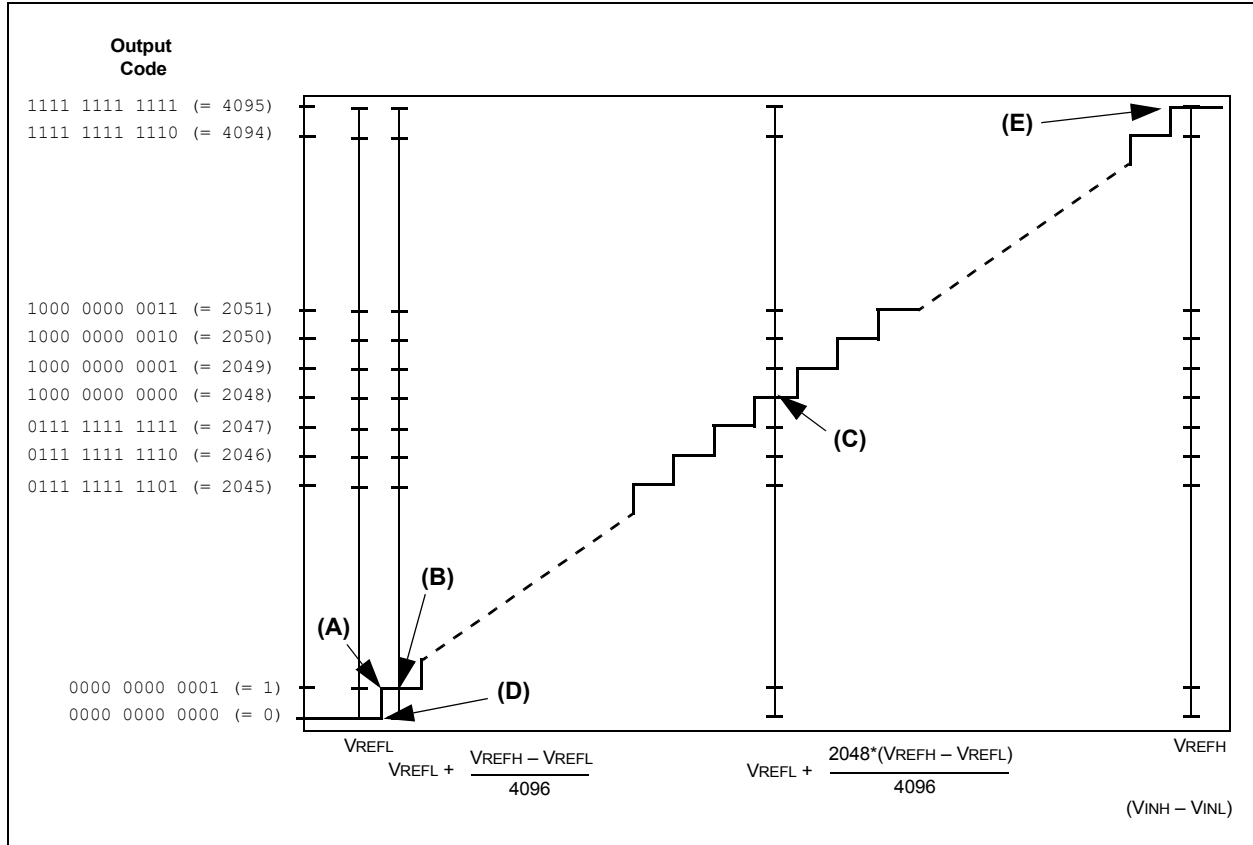

## 16.19 ADC ACCURACY/ERROR

Refer to **Section 16.26 “Related Application Notes”** for a list of documents that discuss ADC accuracy.

## 16.20 CONNECTION CONSIDERATIONS

Since the analog inputs employ ESD protection, they have diodes to VDD and VSS. As a result, the analog input must be between VDD and VSS. If the input voltage exceeds this range by greater than 0.3 V (either direction), one of the diodes becomes forward biased, and it may damage the device if the input current specification is exceeded.

An external RC filter is sometimes added for anti-aliasing of the input signal. The R component should be selected to ensure that the sampling time requirements are satisfied. Any external components connected (via high-impedance) to an analog input pin (capacitor, zener diode, etc.) should have very little leakage current at the pin.

## 16.21 CODE EXAMPLES

Two code examples that demonstrate typical ADC usage scenarios are described here:

### 16.21.1 Channel Scanning Using DMA

Example 16-4 configures a DMA channel for storing 32 ADC results in the Scatter/Gather mode. The ADC is set up to scan four analog inputs (AN0, AN1, AN2, AN3), thereby providing eight samples of each input in the DMA buffer.

### 16.21.2 Alternate Sampling Using DMA

Example 16-5 performs alternate sampling of two analog inputs (AN4, AN5) and stores the results in a 32-word DMA buffer using the Scatter/Gather mode.

**Example 16-4: Code for Channel Scanning Using DMA**

```

/*****
* © 2005 Microchip Technology Inc.
*
* FileName:          adcDrvl.c
* Dependencies:     Header (.h) files if applicable, see below
* Processor:        PIC24Hxxxx
* Compiler:         MPLAB® C30 v2.01.00 or higher
*
* SOFTWARE LICENSE AGREEMENT:
* Microchip Technology Inc. ("Microchip") licenses this software to you solely for use with
* Microchip dsPIC® digital signal controller products. The software is owned by Microchip
* and is protected under applicable copyright laws. All rights reserved.
*
* SOFTWARE IS PROVIDED "AS IS." MICROCHIP EXPRESSLY DISCLAIMS ANY WARRANTY OF ANY KIND,
* WHETHER EXPRESS OR IMPLIED, INCLUDING BUT NOT LIMITED TO, THE IMPLIED WARRANTIES OF
* MERCHANTABILITY, FITNESS FOR A PARTICULAR PURPOSE, OR NON-INFRINGEMENT. IN NO EVENT SHALL
* MICROCHIP BE LIABLE FOR ANY INCIDENTAL, SPECIAL, INDIRECT OR CONSEQUENTIAL DAMAGES, LOST
* PROFITS OR LOST DATA, HARM TO YOUR EQUIPMENT, COST OF PROCUREMENT OF SUBSTITUTE GOODS,
* TECHNOLOGY OR SERVICES, ANY CLAIMS BY THIRD PARTIES (INCLUDING BUT NOT LIMITED TO ANY
* DEFENSE THEREOF), ANY CLAIMS FOR INDEMNITY OR CONTRIBUTION, OR OTHER SIMILAR COSTS.
*
*****/

#if defined(__dsPIC33F__)
#include "p33fxxxx.h"
#elif defined(__PIC24H__)
#include "p24hxxxx.h"
#endif

void ProcessADCSamples(unsigned int * AdcBuffer);

/*=====
ADC Initialization for Channel Scan
=====*/
void initAdc1(void)
{
    AD1CON1bits.FORM    = 1;    // Data Output Format: Signed Integer
    AD1CON1bits.SSRC    = 2;    // Sample Clock Source: GP Timer starts conversion
    AD1CON1bits.ASAM    = 1;    // ADC Sample Control: Sampling begins immediately after conversion
    AD1CON1bits.AD12B   = 0;    // 10-bit ADC operation
    AD1CON1bits.SIMSAM  = 0;    // Samples multiple channels individually in sequence

    AD1CON2bits.BUFGM   = 0;
    AD1CON2bits.CSCNA   = 1;    // Scan Input Selections for CH0+ during Sample A bit
    AD1CON2bits.CHPS    = 0;    // Converts CH0

    AD1CON3bits.ADRC    = 0;    // ADC Clock is derived from Systems Clock
    AD1CON3bits.ADCS    = 63;   // ADC Conversion Clock

    //AD1CHS0: A/D Input Select Register
    AD1CHS0bits.CH0SA   = 0;    // MUXA +ve input selection (AIN0) for CH0
    AD1CHS0bits.CH0NA   = 0;    // MUXA -ve input selection (Vref-) for CH0
}

```

# PIC24H Family Reference Manual

## Example 16-4: Code for Channel Scanning Using DMA (Continued)

```
//AD1CHS123: A/D Input Select Register
AD1CHS123bits.CH123SA = 0;    // MUXA +ve input selection (AIN0) for CH1
AD1CHS123bits.CH123NA = 0;    // MUXA -ve input selection (Vref-) for CH1

//AD1CSSH/AD1CSSL: A/D Input Scan Selection Register
AD1CSSH = 0x0000;
AD1CSSL = 0x000F;            // Scan AIN0, AIN1, AIN2, AIN3 inputs

AD1CON1bits.ADDMABM = 0;      // DMA buffers are built in scatter/gather mode
AD1CON2bits.SMPI    = 3;      // 4 ADC buffers
AD1CON4bits.DMABL   = 3;      // Each buffer contains 8 words

IFS0bits.AD1IF      = 0;      // Clear the A/D interrupt flag bit
IEC0bits.AD1IE      = 0;      // Do Not Enable A/D interrupt
AD1CON1bits.ADON    = 1;      // Turn on the A/D converter

}

/*=====
Timer 3 is setup to time-out every 125 microseconds (8Khz Rate). As a result, the module
will stop sampling and trigger a conversion on every Timer3 time-out, i.e., Ts=125us.
=====*/
void initTmr3()
{
    TMR3 = 0x0000;
    PR3  = 4999;              // Trigger ADC1 every 125usec
    IFS0bits.T3IF = 0;        // Clear Timer 3 interrupt
    IEC0bits.T3IE = 0;        // Disable Timer 3 interrupt

    T3CONbits.TON = 1;        //Start Timer 3
}

// Linker will allocate these buffers from the bottom of DMA RAM.
struct
{
    unsigned int Adc1Ch0[8];
    unsigned int Adc1Ch1[8];
    unsigned int Adc1Ch2[8];
    unsigned int Adc1Ch3[8];
} BufferA __attribute__((space(dma)));

struct
{
    unsigned int Adc1Ch0[8];
    unsigned int Adc1Ch1[8];
    unsigned int Adc1Ch2[8];
    unsigned int Adc1Ch3[8];
} BufferB __attribute__((space(dma)));

// DMA0 configuration
// Direction: Read from peripheral address 0-x300 (ADC1BUF0) and write to DMA RAM
// AMODE: Peripheral Indirect Addressing Mode
// MODE: Continuous, Ping-Pong Mode
// IRQ: ADC Interrupt
```



**Example 16-4: Code for Channel Scanning Using DMA (Continued)**

```

void initDma0(void)
{
    DMA0CONbits.AMODE = 2;           // Configure DMA for Peripheral indirect mode
    DMA0CONbits.MODE = 2;           // Configure DMA for Continuous Ping-Pong mode
    DMA0PAD = 0x0300;               // Point DMA to ADC1BUF0
    DMA0CNT = 31;                   // 32 DMA request (4 buffers, each with 8 words)
    DMA0REQ = 13;                   // Select ADC1 as DMA Request source

    DMA0STA = __builtin_dmaoffset(&BufferA);
    DMA0STB = __builtin_dmaoffset(&BufferB);

    IFS0bits.DMA0IF = 0;            //Clear the DMA interrupt flag bit
    IEC0bits.DMA0IE = 1;            //Set the DMA interrupt enable bit

    DMA0CONbits.CHEN=1;             // Enable DMA
}

/*=====
_DMA0Interrupt(): ISR name is chosen from the device linker script.
=====*/

unsigned int DmaBuffer = 0;

void __attribute__((__interrupt__)) _DMA0Interrupt(void)
{
    if(DmaBuffer == 0)
    {
        ProcessADCSamples(BufferA.Adc1Ch0);
        ProcessADCSamples(BufferA.Adc1Ch1);
        ProcessADCSamples(BufferA.Adc1Ch2);
        ProcessADCSamples(BufferA.Adc1Ch3);
    }
    else
    {
        ProcessADCSamples(BufferB.Adc1Ch0);
        ProcessADCSamples(BufferB.Adc1Ch1);
        ProcessADCSamples(BufferB.Adc1Ch2);
        ProcessADCSamples(BufferB.Adc1Ch3);
    }

    DmaBuffer ^= 1;

    IFS0bits.DMA0IF = 0;            //Clear the DMA0 Interrupt Flag
}

void ProcessADCSamples(unsigned int * AdcBuffer)
{
    /* Do something with ADC Samples */
}

```

# PIC24H Family Reference Manual

## Example 16-5: Code for Alternate Sampling Using DMA

```
/******  
* © 2005 Microchip Technology Inc.  
*  
* FileName:          adcDrvl.c  
* Dependencies:      Header (.h) files if applicable, see below  
* Processor:         PIC24Hxxxx  
* Compiler:          MPLAB® C30 v2.01.00 or higher  
*  
* SOFTWARE LICENSE AGREEMENT:  
* Microchip Technology Inc. ("Microchip") licenses this software to you solely for use with  
* Microchip dsPIC® digital signal controller products. The software is owned by Microchip  
* and is protected under applicable copyright laws. All rights reserved.  
* *  
* SOFTWARE IS PROVIDED "AS IS." MICROCHIP EXPRESSLY DISCLAIMS ANY WARRANTY OF ANY KIND,  
* WHETHER EXPRESS OR IMPLIED, INCLUDING BUT NOT LIMITED TO, THE IMPLIED WARRANTIES OF  
* MERCHANTABILITY, FITNESS FOR A PARTICULAR PURPOSE, OR NON-INFRINGEMENT. IN NO EVENT  
* SHALL MICROCHIP BE LIABLE FOR ANY INCIDENTAL, SPECIAL, INDIRECT OR CONSEQUENTIAL DAMAGES,  
* LOST PROFITS OR LOST DATA, HARM TO YOUR EQUIPMENT, COST OF PROCUREMENT OF SUBSTITUTE GOODS,  
* TECHNOLOGY OR SERVICES, ANY CLAIMS BY THIRD PARTIES (INCLUDING BUT NOT LIMITED TO  
* ANY DEFENSE THEREOF), ANY CLAIMS FOR INDEMNITY OR CONTRIBUTION, OR OTHER SIMILAR COSTS.  
*  
*****/  
  
#if defined(__dsPIC33F__)  
#include "p33fxxxx.h"  
#elif defined(__PIC24H__)  
#include "p24hxxxx.h"  
#endif  
  
#include "adcDrvl.h"  
#include "tglPin.h"  
  
// Define Message Buffer Length for ECAN1/ECAN2  
#define MAX_CHNUM 5 // Highest Analog input number enabled for alternate sampling  
#define SAMP_BUFF_SIZE 16 // Size of the input buffer per analog input  
  
// Number of locations for ADC buffer = 2 (AN4 and AN5) x 16 = 32 words  
// Align the buffer to 32words or 64 bytes. This is needed for peripheral indirect mode  
int BufferA[MAX_CHNUM+1][SAMP_BUFF_SIZE] __attribute__((space(dma),aligned(64)));  
int BufferB[MAX_CHNUM+1][SAMP_BUFF_SIZE] __attribute__((space(dma),aligned(64)));  
  
void ProcessADCSamples(int * AdcBuffer);  
  
/*===== ADC Initialisation for Channel Scan =====*/  
void initAdc1(void)  
{  
    AD1CON1bits.FORM = 1; // Data Output Format: Signed Integer  
    AD1CON1bits.SSRC = 2; // Sample Clock Source: GP Timer starts conversion  
    AD1CON1bits.ASAM = 1; // ADC Sample Control: Sampling begins immediately after conversion  
    AD1CON1bits.AD12B = 0; // 10-bit ADC operation  
  
    AD1CON2bits.ALTS=1; // Alternate Input Sample Mode Select Bit  
    AD1CON2bits.CHPS = 0; // Converts CH0
```

**Example 16-5: Code for Alternate Sampling Using DMA (Continued)**

```

    AD1CON3bits.ADRC = 0;      // ADC Clock is derived from Systems Clock
    AD1CON3bits.ADCS = 63;    // ADC Conversion Clock Tad=Tcy*(ADCS+1)=(1/40M)*64 = 1.6us(625Khz)
                                // ADC Conversion Time for 10-bit Tc=12*Tab = 19.2us

    AD1CON1bits.ADDMABM = 0;  // DMA buffers are built in scatter/gather mode
    AD1CON2bits.SMPI = 1;    // SMPI Must be programmed to 1 for this case
    AD1CON4bits.DMABL = 4;   // Each buffer contains 16 words

//AD1CHS0: A/D Input Select Register
    AD1CHS0bits.CH0SA=4;     // MUXA +ve input selection (AIN4) for CH0
    AD1CHS0bits.CH0NA=0;    // MUXA -ve input selection (Vref-) for CH0

    AD1CHS0bits.CH0SB=5;    // MUXB +ve input selection (AIN5) for CH0
    AD1CHS0bits.CH0NB=0;    // MUXB -ve input selection (Vref-) for CH0

//AD1PCFGH/AD1PCFGL: Port Configuration Register
    AD1PCFGL=0xFFFF;
    AD1PCFGH=0xFFFF;
    AD1PCFGLbits.PCFG4 = 0;  // AN4 as Analog Input
    AD1PCFGLbits.PCFG5 = 0;  // AN5 as Analog Input

    IFS0bits.AD1IF = 0;      // Clear the A/D interrupt flag bit
    IEC0bits.AD1IE = 0;     // Do Not Enable A/D interrupt
    AD1CON1bits.ADON = 1;    // Turn on the A/D converter

    tglPinInit();

}

/*=====
Timer 3 is set up to time-out every 125 microseconds (8Khz Rate). As a result, the module
will stop sampling and trigger a conversion on every Timer3 time-out, i.e., Ts=125us.
=====*/
void initTmr3()
{
    TMR3 = 0x0000;
    PR3 = 4999;
    IFS0bits.T3IF = 0;
    IEC0bits.T3IE = 0;

//Start Timer 3
    T3CONbits.TON = 1;

}

// DMA0 configuration
// Direction: Read from peripheral address 0-x300 (ADC1BUF0) and write to DMA RAM
// AMODE: Peripheral Indirect Addressing Mode
// MODE: Continuous, Ping-Pong Mode
// IRQ: ADC Interrupt
// ADC stores results stored alternatively between DMA_BASE[0]/DMA_BASE[16] on every 16th DMA request

void initDma0(void)
{
    DMA0CONbits.AMODE = 2;    // Configure DMA for Peripheral indirect mode
    DMA0CONbits.MODE = 2;    // Configure DMA for Continuous Ping-Pong mode

    DMA0PAD=(int)&ADC1BUF0;
    DMA0CNT = (SAMP_BUFF_SIZE*2)-1;
}

```

# PIC24H Family Reference Manual

## Example 16-5: Code for Alternate Sampling Using DMA (Continued)

```
DMA0REQ=13;

DMA0STA = __builtin_dmaoffset(&BufferA[0][0]);
DMA0STB = __builtin_dmaoffset(&BufferB[0][0]);

IFS0bits.DMA0IF = 0;           //Clear the DMA interrupt flag bit
IEC0bits.DMA0IE = 1;         //Set the DMA interrupt enable bit

DMA0CONbits.CHEN=1;

}

/*=====
_DMA0Interrupt(): ISR name is chosen from the device linker script.
=====*/

unsigned int DmaBuffer = 0;

void __attribute__((__interrupt__)) _DMA0Interrupt(void)
{
    if(DmaBuffer==0) {
        ProcessADCSamples(&BufferA[4][0]);
        ProcessADCSamples(&BufferA[5][0]);
    } else {
        ProcessADCSamples(&BufferB[4][0]);
        ProcessADCSamples(&BufferB[5][0]);
    }

    DmaBuffer ^= 1;

    tglPin();           // Toggle PORTA, BIT0
    IFS0bits.DMA0IF = 0; //Clear the DMA0 Interrupt Flag
}

void ProcessADCSamples(int * AdcBuffer)
{
    /* Do something with ADC Samples */
}
```

## 16.22 OPERATION DURING SLEEP AND IDLE MODES

Sleep and Idle modes are useful for minimizing conversion noise because the digital activity of the CPU, buses and other peripherals is minimized.

### 16.22.1 CPU Sleep Mode without RC A/D Clock

When the device enters Sleep mode, all clock sources to the ADC module are shut down and stay at logic '0'.

If Sleep occurs in the middle of a conversion, the conversion is aborted unless the ADC is clocked from its internal RC clock generator. The converter does not resume a partially completed conversion on exiting from Sleep mode.

Register contents are not affected by the device entering or leaving Sleep mode.

### 16.22.2 CPU Sleep Mode with RC A/D Clock

The ADC module can operate during Sleep mode if the A/D clock source is set to the internal A/D RC oscillator ( $ADRC = 1$ ). This eliminates digital switching noise from the conversion. When the conversion is completed, the DONE bit is set and the result is loaded into the ADC Result buffer, ADCBUF.

If the ADC interrupt is enabled ( $ADxIE = 1$ ), the device wakes up from Sleep when the ADC interrupt occurs. Program execution resumes at the ADC Interrupt Service Routine if the ADC interrupt is greater than the current CPU priority. Otherwise, execution continues from the instruction after the `PWRSVAV` instruction that placed the device in Sleep mode.

If the ADC interrupt is not enabled, the ADC module is turned off, although the ADON bit remains set.

To minimize the effects of digital noise on the ADC module operation, the user should select a conversion trigger source that ensures the A/D conversion will take place in Sleep mode. The automatic conversion trigger option can be used for sampling and conversion in Sleep ( $SSRC<2:0> = 111$ ). To use the automatic conversion option, the ADON bit should be set in the instruction before the `PWRSVAV` instruction.

<b>Note:</b> For the ADC module to operate in Sleep, the ADC clock source must be set to RC ( $ADRC = 1$ ).
---

### 16.22.3 ADC Operation During CPU Idle Mode

For the A/D conversion, the ADSIDL bit ( $ADxCON1<13>$ ) selects if the ADC module stops or continues on Idle. If  $ADSIDL = 0$ , the ADC module continues normal operation when the device enters Idle mode. If the ADC interrupt is enabled ( $ADxIE = 1$ ), the device wakes up from Idle mode when the ADC interrupt occurs. Program execution resumes at the ADC Interrupt Service Routine if the ADC interrupt is greater than the current CPU priority. Otherwise, execution continues from the instruction after the `PWRSVAV` instruction that placed the device in Idle mode.

If  $ADSIDL = 1$ , the ADC module stops in Idle. If the device enters Idle mode in the middle of a conversion, the conversion is aborted. The converter does not resume a partially completed conversion on exiting from Idle mode.

## 16.23 EFFECTS OF A RESET

A device Reset forces all registers to their Reset state. This forces the ADC module to be turned off and any conversion in progress to be aborted. All pins that are multiplexed with analog inputs are configured as analog inputs. The corresponding TRIS bits are set.

The value in the ADCxBUF0 register is not initialized during a Power-on Reset and contain unknown data.

## 16.24 SPECIAL FUNCTION REGISTERS ASSOCIATED WITH THE ADC

The following table lists PIC24H ADC Special Function registers, including their addresses and formats. All unimplemented registers and/or bits within a register are read as zeros.

Table 16-10: ADC Register Map

File Name	ADR	Bit 15	Bit 14	Bit 13	Bit 12	Bit 11	Bit 10	Bit 9	Bit 8	Bit 7	Bit 6	Bit 5	Bit 4	Bit 3	Bit 2	Bit 1	Bit 0	Reset States
INTCON1	0080	NSTDIS	—	—	—	—	—	—	—	—	DIV0ERR	DMACERR	MATHERR	ADDRERR	STKERR	OSCFAIL	—	0000
INTCON2	0082	ALTIVT	DISI	—	—	—	—	—	—	—	—	—	INT4EP	INT3EP	INT2EP	INT1EP	INT0EP	0000
IFS0	0084	—	DMA1IF	AD1IF	U1TXIF	U1RXIF	SPI1IF	SPI1EIF	T3IF	T2IF	OC2IF	IC2IF	DMA0IF	T1IF	OC1IF	IC1IF	INT0IF	0000
IFS1	0086	U2TXIF	U2RXIF	INT2IF	T5IF	T4IF	OC4IF	OC3IF	DMA2IF	IC8IF	IC7IF	AD2IF	INT1IF	CNIF	—	MI2C1IF	SI2C1IF	0000
IEC0	0094	—	DMA1IE	AD1IE	U1TXIE	U1RXIE	SPI1IE	SPI1EIE	T3IE	T2IE	OC2IE	IC2IE	DMA0IE	T1IE	OC1IE	IC1IE	INT0IE	0000
IEC1	0096	U2TXIE	U2RXIE	INT2IE	T5IE	T4IE	OC4IE	OC3IE	DMA2IE	IC8IE	IC7IE	AD2IE	INT1IE	CNIE	—	MI2C1IE	SI2C1IE	0000
IPC3	00AA	—	—	—	—	—	DMA1IP<2:0>			—	AD1IP<2:0>			—	U1TXIP<2:0>			4444
IPC5	00AE	—	IC8IP<2:0>			—	IC7IP<2:0>			—	AD2IP<2:0>			—	INT1IP<2:0>			4444
ADC1BUF0	0300	ADC1 Data Buffer																uuuu
AD1CON1	0320	ADON	—	ADSIDL	ADDMABM	—	AD12B	FORM<1:0>		SSRC<2:0>			—	SIMSAM	ASAM	SAMP	DONE	0000
AD1CON2	0322	VCFG<2:0>			—	—	CSCNA	CHPS<1:0>		BUFS	—	SMPI<3:0>				BUFM	ALTS	0000
AD1CON3	0324	ADRC	—	—	SAMC<4:0>				—	—	ADCS<5:0>							0000
AD1CHS123	0326	—	—	—	—	—	CH123NB<1:0>		CH123SB	—	—	—	—	—	CH123NA<1:0>		CH123SA	0000
AD1CHS0	0328	CH0NB	—	—	CH0SB<4:0>				CH0NA	—	—	CH0SA<4:0>						0000
AD1PCFGH	032A	PCFG31	PCFG30	PCFG29	PCFG28	PCFG27	PCFG26	PCFG25	PCFG24	PCFG23	PCFG22	PCFG21	PCFG20	PCFG19	PCFG18	PCFG17	PCFG16	0000
AD1PCFGL	032C	PCFG15	PCFG14	PCFG13	PCFG12	PCFG11	PCFG10	PCFG9	PCFG8	PCFG7	PCFG6	PCFG5	PCFG4	PCFG3	PCFG2	PCFG1	PCFG0	0000
AD1CSSH	032E	CSS31	CSS30	CSS29	CSS28	CSS27	CSS26	CSS25	CSS24	CSS23	CSS22	CSS21	CSS20	CSS19	CSS18	CSS17	CSS16	0000
AD1CSSL	0330	CSS15	CSS14	CSS13	CSS12	CSS11	CSS10	CSS9	CSS8	CSS7	CSS6	CSS5	CSS4	CSS3	CSS2	CSS1	CSS0	0000
AD1CON4	0332	—	—	—	—	—	—	—	—	—	—	—	—	—	DMABL<2:0>			0000
ADC2BUF0	0340	ADC2 Data Buffer																uuuu
AD2CON1	0360	ADON	—	ADSIDL	ADDMABM	—	AD12B	FORM<1:0>		SSRC<2:0>			—	SIMSAM	ASAM	SAMP	DONE	0000
AD2CON2	0362	VCFG<2:0>			—	—	CSCNA	CHPS<1:0>		BUFS	—	SMPI<3:0>				BUFM	ALTS	0000
AD2CON3	0364	ADRC	—	—	SAMC<4:0>				—	—	ADCS<5:0>							0000
AD2CHS123	0366	—	—	—	—	—	CH123NB<1:0>		CH123SB	—	—	—	—	—	CH123NA<1:0>		CH123SA	0000
AD2CHS0	0368	CH0NB	—	—	CH0SB<3:0>				CH0NA	—	—	CH0SA<3:0>						0000
AD2PCFGL	036C	PCFG15	PCFG14	PCFG13	PCFG12	PCFG11	PCFG10	PCFG9	PCFG8	PCFG7	PCFG6	PCFG5	PCFG4	PCFG3	PCFG2	PCFG1	PCFG0	0000
AD2CSSL	0370	CSS15	CSS14	CSS13	CSS12	CSS11	CSS10	CSS9	CSS8	CSS7	CSS6	CSS5	CSS4	CSS3	CSS2	CSS1	CSS0	0000
AD2CON4	0372	—	—	—	—	—	—	—	—	—	—	—	—	—	DMABL<2:0>			0000

**Legend:** u = unknown

**Note:** All interrupt sources and their associated control bits may not be available on a particular device. Refer to the device data sheet for details.

## 16.25 DESIGN TIPS

**Question 1:** *How can I optimize the system performance of the ADC module?*

**Answer:**

1. Make sure you are meeting all of the timing specifications. If you are turning the ADC module off and on, there is a minimum delay you must wait before taking a sample. If you are changing input channels, there is a minimum delay you must wait for this as well. Finally, there is TAD, which is the time selected for each bit conversion. TAD is selected in ADCON3 and should be within a range as specified in the Electrical Characteristics. If TAD is too short, the result may not be fully converted before the conversion is terminated. If TAD is too long, the voltage on the sampling capacitor can decay before the conversion is complete. These timing specifications are provided in the "Electrical Specifications" section of the device data sheets.
2. Often the source impedance of the analog signal is high (greater than 10 k $\Omega$ ), so the current drawn from the source to charge the sample capacitor can affect accuracy. If the input signal does not change too quickly, try putting a 0.1  $\mu$ F capacitor on the analog input. This capacitor charges to the analog voltage being sampled and supplies the instantaneous current needed to charge the 4.4 pF internal holding capacitor.
3. Put the device into Sleep mode before the start of the A/D conversion. The RC clock source selection is required for conversions in Sleep mode. This technique increases accuracy because digital noise from the CPU and other peripherals is minimized.

**Question 2:** *Do you know of a good reference on ADCs?*

**Answer:** A good reference for understanding A/D conversions is the "*Analog-Digital Conversion Handbook*" third edition, published by Prentice Hall (ISBN 0-13-03-2848-0).

**Question 3:** *My combination of channels/sample and samples/interrupt is greater than the size of the buffer. What will happen to the buffer?*

**Answer:** This configuration is not recommended. The buffer will contain unknown results.



## 16.26 RELATED APPLICATION NOTES

This section lists application notes that are related to this section of the manual. These application notes may not be written specifically for the PIC24H Product Family, but the concepts are pertinent and could be used with modification and possible limitations. The current application notes related to the ADC module are:

Title	Application Note #
Using the Analog-to-Digital (A/D) Converter	AN546
Four Channel Digital Voltmeter with Display and Keyboard	AN557
Understanding A/D Converter Performance Specifications	AN693
Using the dsPIC30F for Sensorless BLDC Control	AN901
Using the dsPIC30F for Vector Control of an ACIM	AN908
Sensored BLDC Motor Control Using the dsPIC30F2010	AN957
An Introduction to AC Induction Motor Control Using the dsPIC30F MCU	AN984

**Note:** Please visit the Microchip web site ([www.microchip.com](http://www.microchip.com)) for additional Application Notes and code examples for the PIC24H family of devices.

## 16.27 REVISION HISTORY

### Revision A (February 2007)

This is the initial release of this document.