



---

---

## Section 9. Watchdog Timer (WDT)

---

---

### HIGHLIGHTS

This section of the manual contains the following major topics:

9.1	Introduction .....	9-2
9.2	WDT Operation .....	9-3
9.3	Register Maps .....	9-7
9.4	Design Tips .....	9-8
9.5	Related Application Notes.....	9-9
9.6	Revision History .....	9-10

**Note:** This family reference manual section is meant to serve as a complement to device data sheets. Depending on the device variant, this manual section may not apply to all PIC24F devices.

Please consult the note at the beginning of the “**Watchdog Timer (WDT)**” chapter in the current device data sheet to check whether this document supports the device you are using.

Device data sheets and family reference manual sections are available for download from the Microchip Worldwide Web site at: <http://www.microchip.com>

## 9.1 INTRODUCTION

The primary function of the Watchdog Timer (WDT) is to reset the microcontroller, in the event of a software malfunction, by resetting the device if it has not been cleared in software. It can also be used to wake the device from Sleep or Idle mode. The WDT is a free-running timer which uses the low-power RC oscillator and requires no external components. Therefore, the WDT will continue to operate even if the system’s primary clock source (e.g., the crystal oscillator) is stopped under normal operation (e.g., in Sleep mode).

A block diagram of the WDT is shown in Figure 9-1.

**Figure 9-1: WDT Block Diagram**

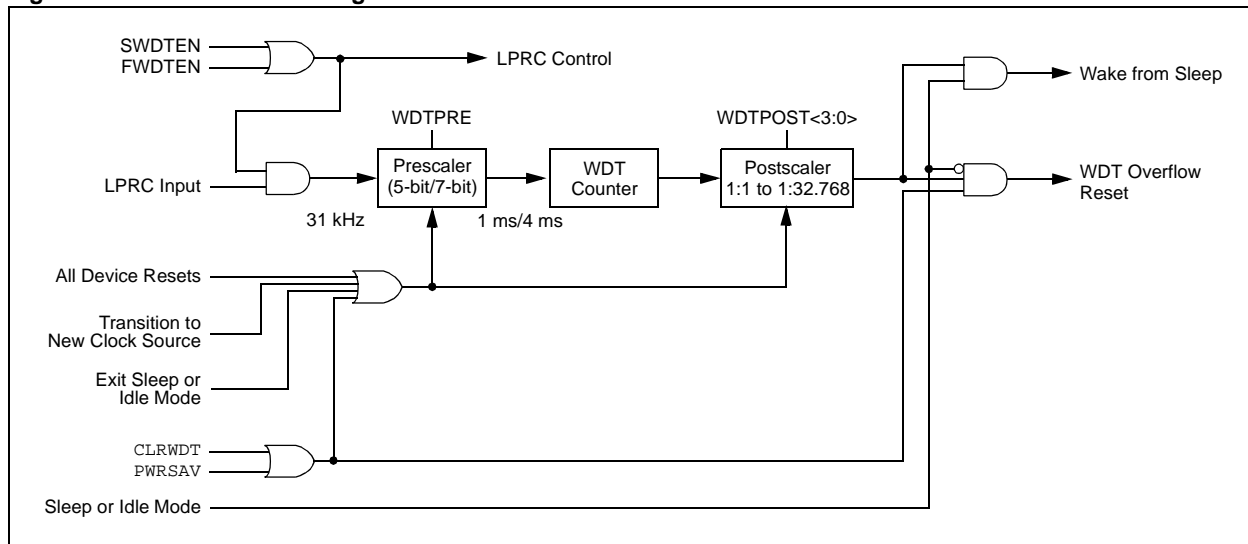

## 9.2 WDT OPERATION

When enabled, the WDT will increment until it overflows or “times out”. A WDT time-out will force a device Reset, except during Sleep or Idle modes. To prevent a WDT Time-out Reset, the user must periodically clear the Watchdog Timer using the instructions, `PWRSVAV` or `CLRWDT`. If the WDT times out during Sleep or Idle modes, the device will wake-up and continue code execution from where the `PWRSVAV` instruction was executed.

In either case, the `WDTO` bit (`RCON<4>`) will be set to indicate that the device Reset or wake-up event was due to a WDT time-out. If the WDT wakes the CPU from Sleep or Idle mode, the `SLEEP` status bit (`RCON<3>`) or `IDLE` status bit (`RCON<2>`) will also be set to indicate that the device was previously in a Power-Saving mode.

**Note:** Refer to the specific device data sheet for details on the `RCON` register bits.

### 9.2.1 Enabling and Disabling the WDT

The WDT is enabled or disabled by the `FWDTEN` (`CW1<7>`) Configuration bit. When the `FWDTEN` Configuration bit is set, the WDT is enabled. This is the default value for an erased device. Refer to the device data sheet for further details on the Flash Configuration Word registers.

### 9.2.2 Software Controlled WDT

If the `FWDTEN` Configuration bit is set, the WDT is always enabled. However, the WDT can be optionally controlled in the user software when the `FWDTEN` Configuration bit has been programmed to ‘0’.

The WDT is enabled in software by setting the `SWDTEN` control bit (`RCON<5>`). The `SWDTEN` control bit is cleared on any device Reset. The software WDT option allows the user to enable the WDT for critical code segments and disable the WDT during non-critical segments for maximum power savings.

### 9.2.3 WDT Window

The Watchdog Timer has an optional Windowed mode enabled by programming the `WINDIS` Configuration bit (`CW1<6>`) to ‘0’. In the Windowed mode, the `CLRWDT` instruction must occur within the allowed window of the WDT period. Any `CLRWDT` instruction that occurs within the disallowed window of the WDT period will cause a WDT Reset, similar to a WDT time-out.

**Note:** The WDT must be enabled (`FWDTEN = 1`) to use WDT Windowed mode.

Some devices have the selectable window bits, `WDTWIN<1:0>`. Table 9-1 lists all possible window options for devices with and without the `WDTWIN<1:0>` bits.

**Table 9-1: Window Bit Options**

<code>WDTWIN&lt;1:0&gt;</code>	Selected Allowed Window
Bits not implemented	25%
11	25%
10	37.50%
01	50%
00	75%

**Figure 9-2: Windowed WDT When WDTWIN<1:0> = 11 or When the WDTWIN<1:0> Bits are not Implemented**

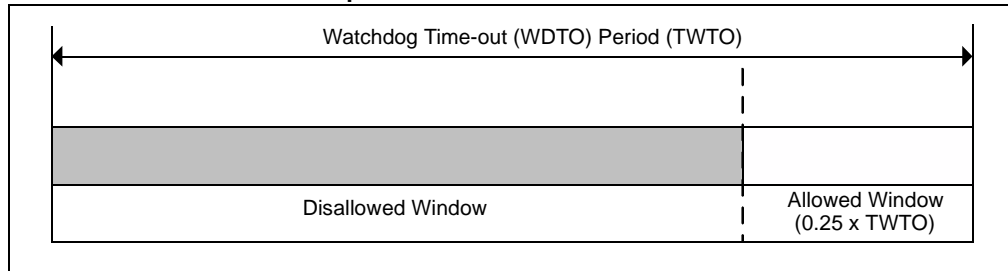

**Figure 9-3: Windowed WDT When WDTWIN<1:0> = 10**

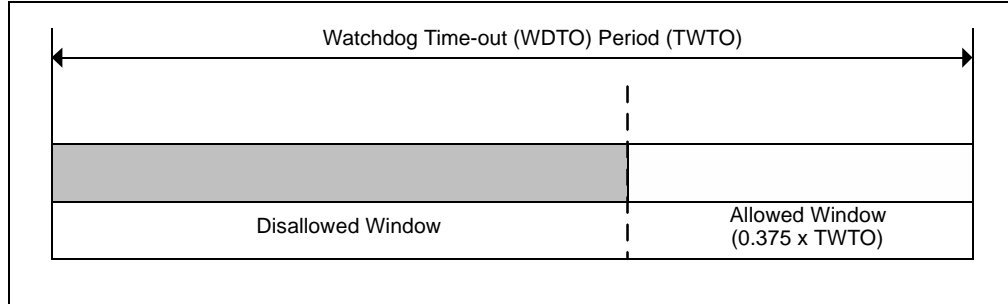

**Figure 9-4: Windowed WDT When WDTWIN<1:0> = 01**

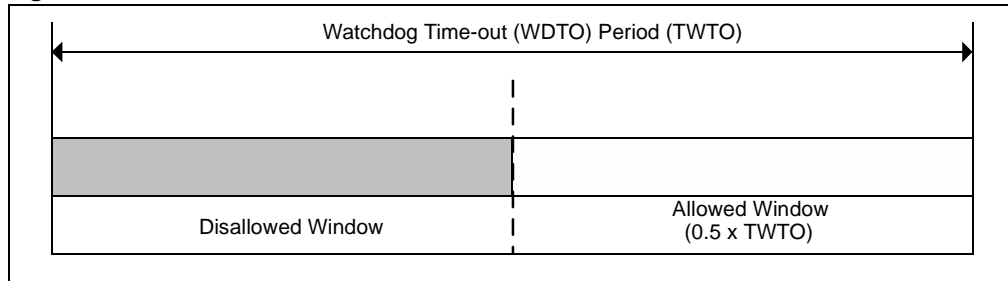

**Figure 9-5: Windowed WDT When WDTWIN<1:0> = 00**

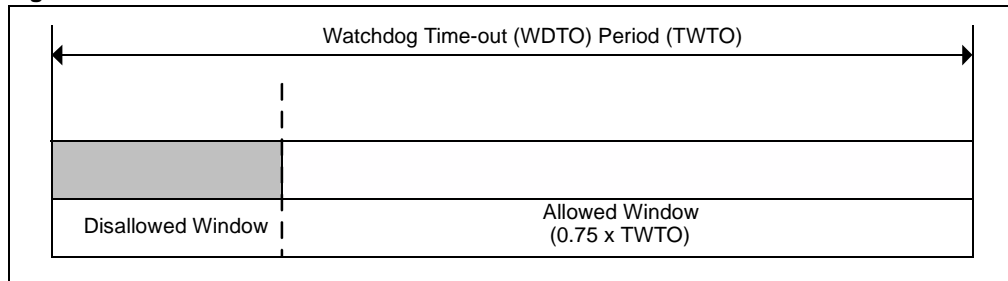

## Section 9. Watchdog Timer (WDT)

### 9.2.4 WDT Prescaler and Timer Period

The WDT clock source is the LPRC oscillator, which has a nominal frequency of 31 kHz. This feeds a prescaler that can be configured for either 5-bit (divide-by-32) or 7-bit (divide-by-128) operation. The prescaler is set by the FWPSA Configuration bit (CW1<4>). With a 31 kHz input, the prescaler yields a nominal WDT time-out period (TWDT) of 1 ms when WDTPRE is clear, or 4 ms when WDTPRE is set.

A variable postscaler divides down the WDT prescaler output and allows for a wide range of time-out periods. The postscaler is controlled by the WDTPOST<3:0> Configuration bits (CW1<3:0>), which allows the selection of a total of 16 settings, from 1:1 to 1:32.768. The WDTPOST bits are configured initially during device programming. Using the prescaler and postscaler, time-out periods ranging from 1 ms to 131 seconds (nominal) can be achieved.

The WDT time-out value can be calculated as shown in Equation 9-1. A complete list of prescaler values and the associated WDT time-out periods is shown in Table 9-2.

**Equation 9-1: WDT Time-out Period**

$$\text{WDT Period (ms)} = \text{Prescaler Factor} \times \text{Postscaler Factor}$$

where:

$$\text{Prescaler Factor} = \begin{cases} 1 & \text{for WDTPRE is '0'} \\ 4 & \text{for WDTPRE is '1'} \end{cases}$$

$$\text{Postscaler Factor} = 1/\text{Postscaler Ratio}$$

**Table 9-2: WDT Configuration and Time-out Period**

Postscaler Setting (WDTPS3:WDTPS0)	Postscaler Ratio (1/Postscaler Factor)	Time-out Period	
		5-bit Prescaler (FWPSA = 0)	7-bit Prescaler (FWPSA = 1)
0000	1:1	1 ms	4 ms
0001	1:2	2 ms	8 ms
0010	1:4	4 ms	16 ms
0011	1:8	8 ms	32 ms
0100	1:16	16 ms	64 ms
0101	1:32	32 ms	128 ms
0110	1:64	64 ms	256 ms
0111	1:128	128 ms	512 ms
1000	1:256	256 ms	1.024s
1001	1:512	512 ms	2.048s
1010	1:1024	1.024s	4.096s
1011	1:2048	2.048s	8.192s
1100	1:4096	4.096s	16.384s
1101	1:8192	8.192s	32.768s
1110	1:16384	16.384s	65.536s
1111	1:32768	32.768s	131.072s

**Note:** The WDT time-out period is directly related to the frequency of the LPRC oscillator, which in turn, may vary as a function of device operating voltage and temperature. Please refer to the appropriate PIC24F device data sheet for LPRC clock frequency specifications.

## 9.2.5 Resetting the Watchdog Timer

The WDT counter and associated prescalers and postscalers are reset:

- On any device Reset
- When a `PWRSVAV` instruction is executed (i.e., Sleep or Idle mode is entered)
- When the WDT is enabled in software
- On the completion of a clock switch, whether invoked by software (i.e., setting the `OSWEN` bit after changing the `NOSC` bits) or by hardware (i.e., Fail-Safe Clock Monitor)
- By a `CLRWDT` instruction during normal execution or during the allowed window of the WDT time-out period if `WINDIS` is '0' (depending on the `WDTWIN` setting).

## 9.2.6 Watchdog Timer Operation in Sleep and Idle Modes

If the WDT is enabled, it will continue to run during Sleep or Idle modes. When the WDT time-out occurs, it will wake the device and code execution will continue from where the instruction was executed.

The WDT is useful for low-power system designs, because it can be used to periodically wake the device from Sleep mode to check system status and provide action if necessary. Note that the `SWDTEN` bit is very useful in this respect. If the WDT is disabled during normal operation (`FWDTEN = 0`), then the `SWDTEN` bit (`RCON<5>`) can be used to turn on the WDT just before entering Sleep mode.

## 9.3 REGISTER MAPS

A summary of the Special Function Registers associated with the PIC24F Watchdog Timer (WDT) module is provided in Table 9-3.

**Table 9-3: Special Function Register Map Associated with the Watchdog Timer**

File Name	Bit 15	Bit 14	Bit 13	Bit 12	Bit 11	Bit 10	Bit 9	Bit 8	Bit 7	Bit 6	Bit 5	Bit 4	Bit 3	Bit 2	Bit 1	Bit 0	All Resets
RCON	TRAPR	IOPUWR	—	—	—	—	CM	VREGS	EXTR	SWR	SWDTEN	WDTO	SLEEP	IDLE	BOR	POR	xxxxx <sup>(1)</sup>

**Legend:** x = unknown value on Reset, — = unimplemented, read as '0'. Reset values are shown in hexadecimal.

**Note 1:** RCON register reset values dependent on type of reset. Refer to the specific device data sheet for detailed information on the RCON register bits.

## 9.4 DESIGN TIPS

**Question 1:** *Why does the device reset, even though I have inserted a CLRWDT instruction in my main software loop?*

**Answer:** Make sure that the software loop that contains the instruction meets the minimum specification of the WDT (not the typical value). Also, make sure that interrupt processing time has been accounted for.

**Question 2:** *What are good techniques for using the WDT in my application?*

**Answer:** There are many techniques for using the WDT to prevent applications from locking up or running away. When they are carefully analyzed, most of them depend on three basic principles:

1. Use one, and only one, CLRWDT instruction in your application. Placing multiple occurrences throughout the application makes it more difficult to troubleshoot time-out issues.
2. Place the CLRWDT instruction inside the main body of the application and not inside a subroutine or an Interrupt Service Routine (ISR). If the instruction is located inside a frequently called routine, there is a good chance that the WDT will constantly be reset and never time-out.
3. Once the application is compiled and sized, place unconditional branch instructions (such as, "GOTO .") throughout the unused area of program memory. If something should happen that makes the code "run away" by branching into unused code space, the GOTO instructions can bring the microcontroller back to your code, where the WDT can help bring the application back under control.



## 9.5 RELATED APPLICATION NOTES

This section lists application notes that are related to this section of the manual. These application notes may not be written specifically for the PIC24F device family, but the concepts are pertinent and could be used with modification and possible limitations. The current application notes related to the Watchdog Timer (WDT) module are:

Title	Application Note #
Low-Power Design using PICmicro® Microcontrollers	AN606

**Note:** Please visit the Microchip web site ([www.microchip.com](http://www.microchip.com)) for additional application notes and code examples for the PIC24F family of devices.

## 9.6 REVISION HISTORY

### **Revision A (May 2006)**

This is the initial released revision of this document.

### **Revision B (August 2010)**

This revision contains the following updates:

- Updated 9.2.3 “WDT Window”
- Added Table 9-1
- Added Figure 9-2 through Figure 9-5
- Minor edits to text and formatting have been incorporated throughout the document

---

**Note the following details of the code protection feature on Microchip devices:**

- Microchip products meet the specification contained in their particular Microchip Data Sheet.
- Microchip believes that its family of products is one of the most secure families of its kind on the market today, when used in the intended manner and under normal conditions.
- There are dishonest and possibly illegal methods used to breach the code protection feature. All of these methods, to our knowledge, require using the Microchip products in a manner outside the operating specifications contained in Microchip's Data Sheets. Most likely, the person doing so is engaged in theft of intellectual property.
- Microchip is willing to work with the customer who is concerned about the integrity of their code.
- Neither Microchip nor any other semiconductor manufacturer can guarantee the security of their code. Code protection does not mean that we are guaranteeing the product as “unbreakable.”

Code protection is constantly evolving. We at Microchip are committed to continuously improving the code protection features of our products. Attempts to break Microchip's code protection feature may be a violation of the Digital Millennium Copyright Act. If such acts allow unauthorized access to your software or other copyrighted work, you may have a right to sue for relief under that Act.

---

Information contained in this publication regarding device applications and the like is provided only for your convenience and may be superseded by updates. It is your responsibility to ensure that your application meets with your specifications. MICROCHIP MAKES NO REPRESENTATIONS OR WARRANTIES OF ANY KIND WHETHER EXPRESS OR IMPLIED, WRITTEN OR ORAL, STATUTORY OR OTHERWISE, RELATED TO THE INFORMATION, INCLUDING BUT NOT LIMITED TO ITS CONDITION, QUALITY, PERFORMANCE, MERCHANTABILITY OR FITNESS FOR PURPOSE. Microchip disclaims all liability arising from this information and its use. Use of Microchip devices in life support and/or safety applications is entirely at the buyer's risk, and the buyer agrees to defend, indemnify and hold harmless Microchip from any and all damages, claims, suits, or expenses resulting from such use. No licenses are conveyed, implicitly or otherwise, under any Microchip intellectual property rights.

**Trademarks**

The Microchip name and logo, the Microchip logo, dsPIC, KEELOQ, KEELOQ logo, MPLAB, PIC, PICmicro, PICSTART, PIC<sup>32</sup> logo, rPIC and UNI/O are registered trademarks of Microchip Technology Incorporated in the U.S.A. and other countries.

FilterLab, Hampshire, HI-TECH C, Linear Active Thermistor, MXDEV, MXLAB, SEEVAL and The Embedded Control Solutions Company are registered trademarks of Microchip Technology Incorporated in the U.S.A.

Analog-for-the-Digital Age, Application Maestro, CodeGuard, dsPICDEM, dsPICDEM.net, dsPICworks, dsSPEAK, ECAN, ECONOMONITOR, FanSense, HI-TIDE, In-Circuit Serial Programming, ICSP, Mindi, MiWi, MPASM, MPLAB Certified logo, MPLIB, MPLINK, mTouch, Octopus, Omniscient Code Generation, PICC, PICC-18, PICDEM, PICDEM.net, PICkit, PICTail, REAL ICE, rLAB, Select Mode, Total Endurance, TSHARC, UniWinDriver, WiperLock and ZENA are trademarks of Microchip Technology Incorporated in the U.S.A. and other countries.

SQTP is a service mark of Microchip Technology Incorporated in the U.S.A.

All other trademarks mentioned herein are property of their respective companies.

© 2010, Microchip Technology Incorporated, Printed in the U.S.A., All Rights Reserved.

 Printed on recycled paper.

ISBN: 978-1-60932-478-0

*Microchip received ISO/TS-16949:2002 certification for its worldwide headquarters, design and wafer fabrication facilities in Chandler and Tempe, Arizona; Gresham, Oregon and design centers in California and India. The Company's quality system processes and procedures are for its PIC<sup>®</sup> MCUs and dsPIC<sup>®</sup> DSCs, KEELOQ<sup>®</sup> code hopping devices, Serial EEPROMs, microperipherals, nonvolatile memory and analog products. In addition, Microchip's quality system for the design and manufacture of development systems is ISO 9001:2000 certified.*

**QUALITY MANAGEMENT SYSTEM  
CERTIFIED BY DNV  
== ISO/TS 16949:2002 ==**



# MICROCHIP

## Worldwide Sales and Service

### AMERICAS

**Corporate Office**  
2355 West Chandler Blvd.  
Chandler, AZ 85224-6199  
Tel: 480-792-7200  
Fax: 480-792-7277  
Technical Support:  
<http://support.microchip.com>  
Web Address:  
[www.microchip.com](http://www.microchip.com)

**Atlanta**  
Duluth, GA  
Tel: 678-957-9614  
Fax: 678-957-1455

**Boston**  
Westborough, MA  
Tel: 774-760-0087  
Fax: 774-760-0088

**Chicago**  
Itasca, IL  
Tel: 630-285-0071  
Fax: 630-285-0075

**Cleveland**  
Independence, OH  
Tel: 216-447-0464  
Fax: 216-447-0643

**Dallas**  
Addison, TX  
Tel: 972-818-7423  
Fax: 972-818-2924

**Detroit**  
Farmington Hills, MI  
Tel: 248-538-2250  
Fax: 248-538-2260

**Kokomo**  
Kokomo, IN  
Tel: 765-864-8360  
Fax: 765-864-8387

**Los Angeles**  
Mission Viejo, CA  
Tel: 949-462-9523  
Fax: 949-462-9608

**Santa Clara**  
Santa Clara, CA  
Tel: 408-961-6444  
Fax: 408-961-6445

**Toronto**  
Mississauga, Ontario,  
Canada  
Tel: 905-673-0699  
Fax: 905-673-6509

### ASIA/PACIFIC

**Asia Pacific Office**  
Suites 3707-14, 37th Floor  
Tower 6, The Gateway  
Harbour City, Kowloon  
Hong Kong  
Tel: 852-2401-1200  
Fax: 852-2401-3431

**Australia - Sydney**  
Tel: 61-2-9868-6733  
Fax: 61-2-9868-6755

**China - Beijing**  
Tel: 86-10-8528-2100  
Fax: 86-10-8528-2104

**China - Chengdu**  
Tel: 86-28-8665-5511  
Fax: 86-28-8665-7889

**China - Chongqing**  
Tel: 86-23-8980-9588  
Fax: 86-23-8980-9500

**China - Hong Kong SAR**  
Tel: 852-2401-1200  
Fax: 852-2401-3431

**China - Nanjing**  
Tel: 86-25-8473-2460  
Fax: 86-25-8473-2470

**China - Qingdao**  
Tel: 86-532-8502-7355  
Fax: 86-532-8502-7205

**China - Shanghai**  
Tel: 86-21-5407-5533  
Fax: 86-21-5407-5066

**China - Shenyang**  
Tel: 86-24-2334-2829  
Fax: 86-24-2334-2393

**China - Shenzhen**  
Tel: 86-755-8203-2660  
Fax: 86-755-8203-1760

**China - Wuhan**  
Tel: 86-27-5980-5300  
Fax: 86-27-5980-5118

**China - Xian**  
Tel: 86-29-8833-7252  
Fax: 86-29-8833-7256

**China - Xiamen**  
Tel: 86-592-2388138  
Fax: 86-592-2388130

**China - Zhuhai**  
Tel: 86-756-3210040  
Fax: 86-756-3210049

### ASIA/PACIFIC

**India - Bangalore**  
Tel: 91-80-3090-4444  
Fax: 91-80-3090-4123

**India - New Delhi**  
Tel: 91-11-4160-8631  
Fax: 91-11-4160-8632

**India - Pune**  
Tel: 91-20-2566-1512  
Fax: 91-20-2566-1513

**Japan - Yokohama**  
Tel: 81-45-471- 6166  
Fax: 81-45-471-6122

**Korea - Daegu**  
Tel: 82-53-744-4301  
Fax: 82-53-744-4302

**Korea - Seoul**  
Tel: 82-2-554-7200  
Fax: 82-2-558-5932 or  
82-2-558-5934

**Malaysia - Kuala Lumpur**  
Tel: 60-3-6201-9857  
Fax: 60-3-6201-9859

**Malaysia - Penang**  
Tel: 60-4-227-8870  
Fax: 60-4-227-4068

**Philippines - Manila**  
Tel: 63-2-634-9065  
Fax: 63-2-634-9069

**Singapore**  
Tel: 65-6334-8870  
Fax: 65-6334-8850

**Taiwan - Hsin Chu**  
Tel: 886-3-6578-300  
Fax: 886-3-6578-370

**Taiwan - Kaohsiung**  
Tel: 886-7-213-7830  
Fax: 886-7-330-9305

**Taiwan - Taipei**  
Tel: 886-2-2500-6610  
Fax: 886-2-2508-0102

**Thailand - Bangkok**  
Tel: 66-2-694-1351  
Fax: 66-2-694-1350

### EUROPE

**Austria - Wels**  
Tel: 43-7242-2244-39  
Fax: 43-7242-2244-393

**Denmark - Copenhagen**  
Tel: 45-4450-2828  
Fax: 45-4485-2829

**France - Paris**  
Tel: 33-1-69-53-63-20  
Fax: 33-1-69-30-90-79

**Germany - Munich**  
Tel: 49-89-627-144-0  
Fax: 49-89-627-144-44

**Italy - Milan**  
Tel: 39-0331-742611  
Fax: 39-0331-466781

**Netherlands - Drunen**  
Tel: 31-416-690399  
Fax: 31-416-690340

**Spain - Madrid**  
Tel: 34-91-708-08-90  
Fax: 34-91-708-08-91

**UK - Wokingham**  
Tel: 44-118-921-5869  
Fax: 44-118-921-5820

08/04/10