Section 23. Serial Peripheral Interface (SPI)

HIGHLIGHTS

This section of the manual contains the following major topics:

23.1	Introduction	23-2
23.2	Status and Control Registers	23-3
23.3	Modes of Operation	23-7
23.4	Master Mode Clock Frequency	23-18
23.5	Operation in Power-Saving Modes	23-19
23.6	Register Maps	23-20
23.7	Electrical Specifications	23-21
23.8	Related Application Notes	23-25
23.9	Revision History	23-26

23.1 INTRODUCTION

The Serial Peripheral Interface (SPI) module is a synchronous serial interface useful for communicating with other peripheral or microcontroller devices. These peripheral devices may be serial EEPROMs, shift registers, display drivers, A/D converters, etc. The SPI module is compatible with Motorola's SPI and SIOP interfaces.

Depending on the variant, the PIC24F family offers one or two SPI modules on a single device. The modules, designated SPI1 and SPI2, are functionally identical. The SPI2 module is available in many of the higher pin count packages, while the SPI1 module is available on all devices.

Note: In this section, the SPI modules are referred to together as SPIx, or separately as SPI1 and SPI2. Special Function Registers will follow a similar notation. For example, SPIxCON refers to the control register for the SPI1 or SPI2 module.

The SPIx serial interface consists of four pins:

- SDIx: Serial Data Input
- SDOx: Serial Data Output
- SCKx: Shift Clock Input or Output
- SSx/FSYNCx: Active-Low Slave Select or Frame Synchronization I/O Pulse

The SPIx module can be configured to operate using 2, 3 or 4 pins. In the 3-pin mode, SSx/FSYNCx is not used. In the 2-pin mode, both SDOx and SSx/FSYNCx are not used.

A block diagram of the module is shown in Figure 23-1.

Figure 23-1: SPIx Module Block Diagram

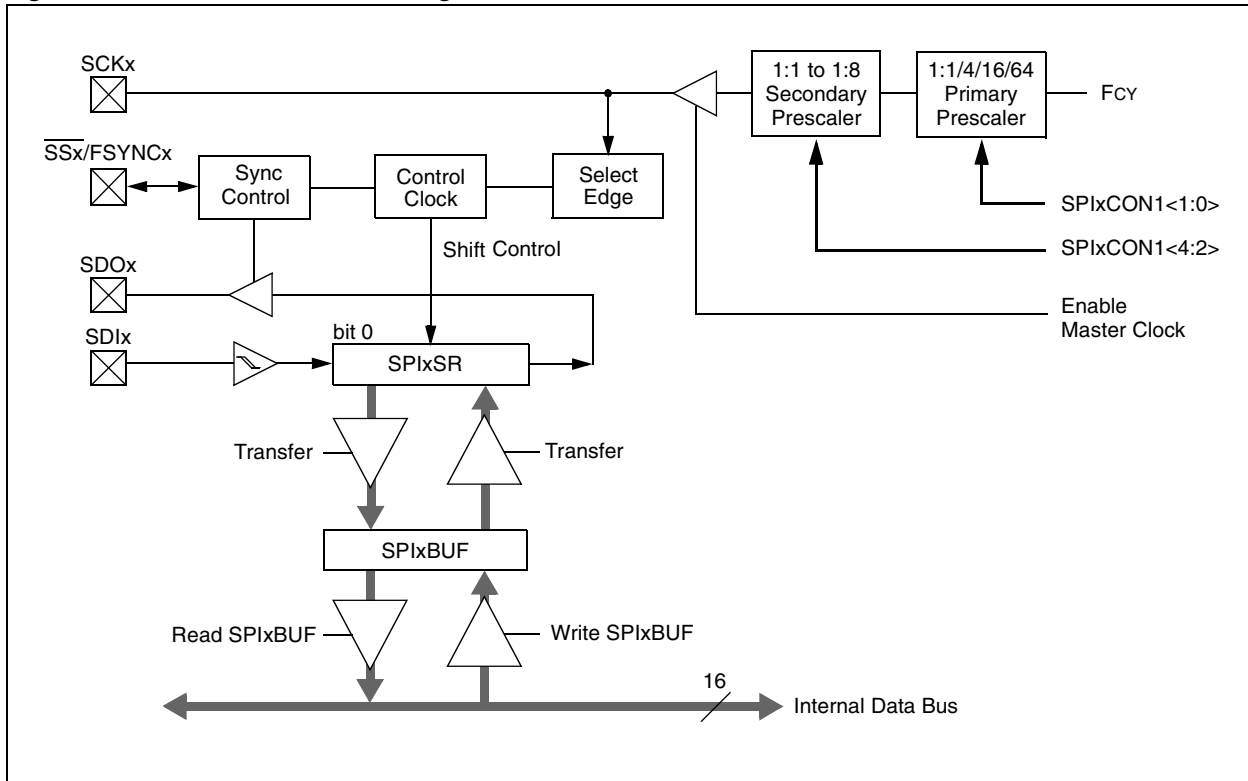

23.2 STATUS AND CONTROL REGISTERS

The SPI serial port consists of the following Special Function Registers:

- SPIxBUF: The address in SFR space that is used to buffer data to be transmitted and data that is received. This address is shared by the virtual SPIxTXB and SPIxRXB registers.
- SPIxCON1 and SPIxCON2: Control registers that configure the module for various modes of operation.
- SPIxSTAT: A status register that indicates various status conditions.

In addition, a 16-bit shift register, SPIxSR, is used for shifting data in and out of the SPI port. The shift register is not memory mapped.

23.2.1 SPIxBUF Register

The memory mapped register, SPIxBUF, is the SPIx Data Receive/Transmit register. The SPIxBUF register is actually comprised of two separate registers: the Transmit Buffer, SPIxTXB, and the Receive Buffer, SPIxRXB. These two unidirectional, 16-bit registers share the SFR address of SPIxBUF. If a user writes data to be transmitted to the SPIxBUF address, internally the data is written to the SPIxTXB register. Similarly, when the user reads the received data from SPIxBUF, internally the data is read from the SPIxRXB register.

This technique double-buffers transmit and receive operations and allows continuous data transfers in the background. Transmission and reception occur simultaneously.

23.2.2 Status and Control Registers

The SPIxSTAT and SPIxCON1/SPIxCON2 registers provide the interface to control the module's operation. They are shown in detail in Register 23-1, Register 23-2 and Register 23-3.

PIC24F Family Reference Manual

Register 23-1: SPIxSTAT: SPIx Status and Control Register

R/W-0	U-0	R/W-0	U-0	U-0	R-x	R-x	R-x
SPIEN	—	SPISIDL	—	—	r	r	r
bit 15					bit 8		

U-0	R/C-0	U-0	U-0	U-0	U-0	R-0	R-0
—	SPIROV	—	—	—	—	SPITBF	SPIRBF
bit 7						bit 0	

Legend:	C = Clear only bit (cannot be set in software)		
R = Readable bit	W = Writable bit	U = Unimplemented bit, read as '0'	
-n = Value at POR	'1' = Bit is set	'0' = Bit is cleared	x = Bit is unknown

- bit 15 **SPIEN:** SPIx Enable bit
 - 1 = Enables module and configures SCKx, SDOx, SDIx and \overline{SSx} as serial port pins
 - 0 = Disables module
- bit 14 **Unimplemented:** Read as '0'
- bit 13 **SPISIDL:** Stop in Idle Mode bit
 - 1 = Discontinue module operation when device enters Idle mode
 - 0 = Continue module operation in Idle mode
- bit 12-11 **Unimplemented:** Read as '0'
- bit 10-8 **Reserved:** Value unknown
- bit 7 **Unimplemented:** Read as '0'
- bit 6 **SPIROV:** Receive Overflow Flag bit
 - 1 = A new byte/word is completely received and discarded. The user software has not read the previous data in the SPIxBUF register.
 - 0 = No overflow has occurred
- bit 5-2 **Unimplemented:** Read as '0'
- bit 1 **SPITBF:** SPIx Transmit Buffer Full Status bit
 - 1 = Transmit not yet started. SPIxTXB is full. Automatically set in hardware when CPU writes SPIxBUF location, loading SPIxTXB.
 - 0 = Transmit started, SPIxTXB is empty. Automatically cleared in hardware when SPIx module transfers data from SPIxTXB to SPIxSR.
- bit 0 **SPIRBF:** SPIx Receive Buffer Full Status bit
 - 1 = Receive complete, SPIxRXB is full. Automatically set in hardware when SPIx transfers data from SPIxSR to SPIxRXB.
 - 0 = Receive is not complete, SPIxRXB is empty. Automatically cleared in hardware when core reads SPIxBUF location, reading SPIxRXB.

Section 23. Serial Peripheral Interface (SPI)

Register 23-2: SPIxCON1: SPIx Control Register 1

U-0	U-0	U-0	R/W-0	R/W-0	R/W-0	R/W-0	R/W-0	
—	—	—	DISSCK	DISSDO	MODE16	SMP	CKE	
bit 15								bit 8
R/W-0	R/W-0	R/W-0	R/W-0	R/W-0	R/W-0	R/W-0	R/W-0	
SSEN	CKP	MSTEN	SPRE2	SPRE1	SPRE0	PPRE1	PPRE0	
bit 7								bit 0

Legend:

R = Readable bit	W = Writable bit	U = Unimplemented bit, read as '0'
-n = Value at POR	'1' = Bit is set	'0' = Bit is cleared
		x = Bit is unknown

- bit 15-13 **Unimplemented:** Read as '0'
- bit 12 **DISSCK:** Disable SCKx pin bit (SPIx Master modes only)
 - 1 = Internal SPIx clock is disabled, pin functions as I/O
 - 0 = Internal SPIx clock is enabled
- bit 11 **DISSDO:** Disable SDOx Pin bit
 - 1 = SDOx pin is not used by module, pin functions as I/O
 - 0 = SDOx pin is controlled by the module
- bit 10 **MODE16:** Word/Byte Communication Select bit
 - 1 = Communication is word-wide (16 bits)
 - 0 = Communication is byte-wide (8 bits)
- bit 9 **SMP:** SPIx Data Input Sample Phase bit
 - Master mode:
 - 1 = Input data sampled at end of data output time
 - 0 = Input data sampled at middle of data output time
 - Slave mode:
 - SMP must be cleared when SPIx is used in Slave mode.
- bit 8 **CKE:** SPIx Clock Edge Select bit
 - 1 = Serial output data changes on transition from active clock state to Idle clock state (see bit 6)
 - 0 = Serial output data changes on transition from Idle clock state to active clock state (see bit 6).
 - Note:** The CKE bit is not used in the Framed SPIx modes. The user should program this bit to '0' for the Framed SPIx modes (FRMEN = 1).
- bit 7 **SSEN:** Slave Select Enable (Slave mode) bit
 - 1 = \overline{SSx} pin used for Slave mode
 - 0 = \overline{SSx} pin not used by module, pin controlled by port function
- bit 6 **CKP:** Clock Polarity Select bit
 - 1 = Idle state for clock is a high level; active state is a low level
 - 0 = Idle state for clock is a low level; active state is a high level
- bit 5 **MSTEN:** Master Mode Enable bit
 - 1 = Master mode
 - 0 = Slave mode
- bit 4-2 **SPRE2:SPRE0:** Secondary Prescale bits (Master mode)
 - 111 = Secondary prescale 1:1
 - 110 = Secondary prescale 2:1
 - ...
 - 000 = Secondary prescale 8:1
- bit 1-0 **PPRE1:PPRE0:** Primary Prescale bits (Master mode)
 - 11 = Primary prescale 1:1
 - 10 = Primary prescale 4:1
 - 01 = Primary prescale 16:1
 - 00 = Primary prescale 64:1

PIC24F Family Reference Manual

Register 23-3: SPIxCON2: SPIx Control Register 2

R/W-0	R/W-0	U-0	U-0	U-0	U-0	U-0	U-0
FRMEN	SPIFSD	SPIFPOL	—	—	—	—	—
bit 15							bit 8

U-0	U-0	U-0	U-0	U-0	U-0	R/W-0	R-0
—	—	—	—	—	—	SPIFE	r
bit 7							bit 0

Legend:

R = Readable bit	W = Writable bit	U = Unimplemented bit, read as '0'
-n = Value at POR	'1' = Bit is set	'0' = Bit is cleared
		x = Bit is unknown

- bit 15 **FRMEN:** Framed SPIx Support bit
 1 = Framed SPIx support enabled
 0 = Framed SPIx support disabled
- bit 14 **SPIFSD:** Frame Sync Pulse Direction Control on \overline{SSx} pin bit
 1 = Frame sync pulse input (slave)
 0 = Frame sync pulse output (master)
- bit 13 **SPIFPOL:** Frame Sync Pulse Polarity Control on \overline{SSx} pin bit (Framed modes only)
 1 = Frame sync pulse is active-high
 0 = Frame sync pulse is active-low
- bit 12-2 **Unimplemented:** Read as '0'
- bit 1 **SPIFE:** Frame Sync Pulse Edge Select bit
 1 = Frame sync pulse coincides with first bit clock
 0 = Frame sync pulse precedes first bit clock
- bit 0 **Reserved:** Maintain as '0'

23.3 MODES OF OPERATION

The SPI module has flexible operating modes which are discussed in the following subsections:

- 8-Bit and 16-Bit Data Transmission/Reception
- Master and Slave Modes
- Framed SPI Modes

23.3.1 8-Bit vs. 16-Bit Operation

The MODE16 control bit (SPIxCON1<10>) allows the module to communicate in either 8-bit or 16-bit modes. The functionality will be the same for each mode, except for the number of bits that are received and transmitted. Additionally, the following should be noted in this context:

The module is reset when the value of the MODE16 bit is changed. Consequently, the bit should not be changed during normal operation.

Data is transmitted out of bit 7 of the SPIxSR for 8-bit operation, while it is transmitted out of bit 15 of the SPIxSR for 16-bit operation. In both modes, data is shifted into bit 0 of the SPIxSR.

When transmitting or receiving data, 8 clock pulses at the SCKx pin are required to shift in/out data in 8-bit mode, while 16 clock pulses are required in 16-bit mode.

23.3.2 Master and Slave Modes

Data can be thought of as taking a direct path between the Most Significant bit of one module's shift register and the Least Significant bit of the other, and then into the appropriate Transmit or Receive Buffer. The module configured as the master module provides the serial clock and synchronization signals (as required) to the slave device. The relationship between the master and slave modules is shown in Figure 23-2.

Figure 23-2: SPIx Master/Slave Connection

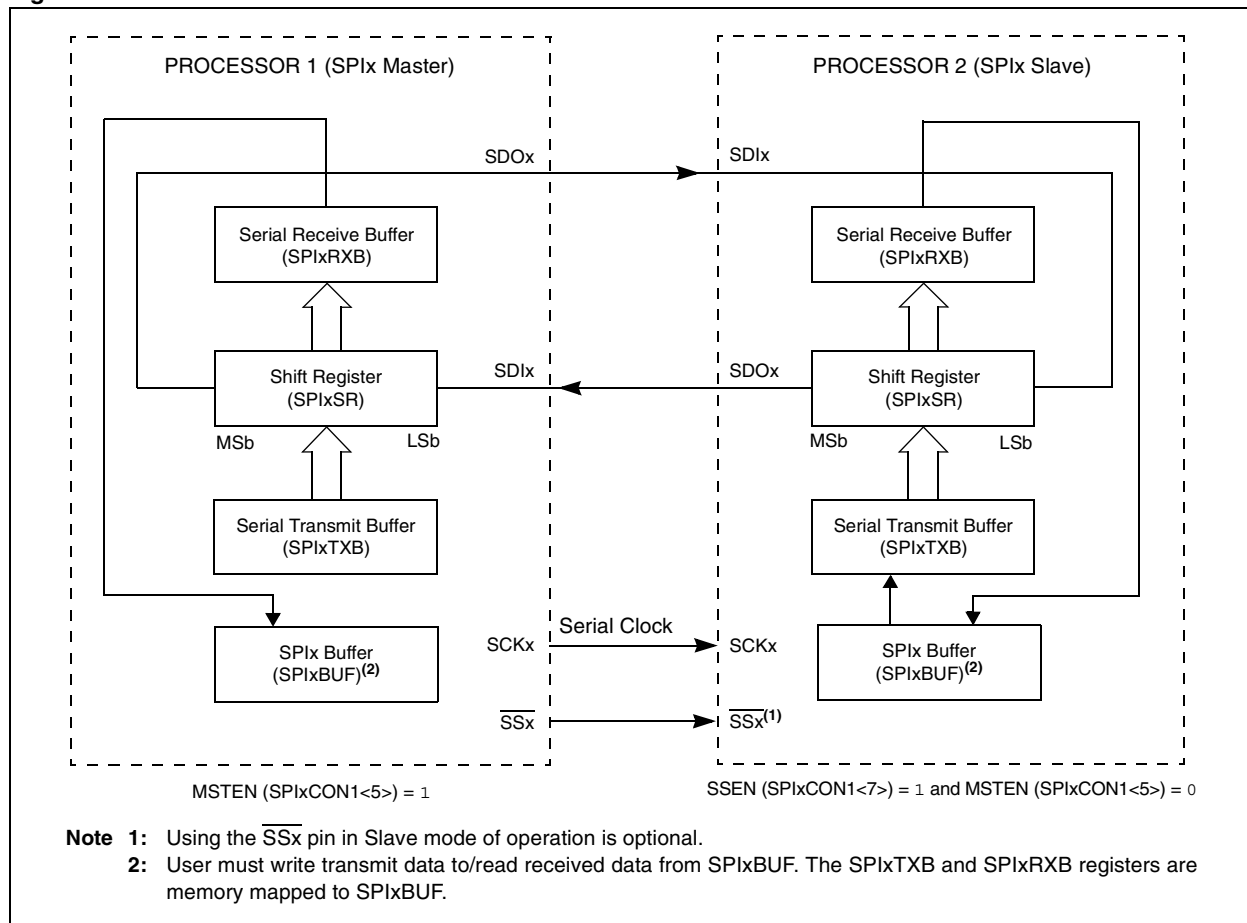

23.3.2.1 MASTER MODE

In Master mode, the system clock is prescaled and then used as the serial clock. The prescaling is based on the settings in the PPRE1:PPRE0 (SPIxCON1<1:0>) and SPRE2:SPRE0 (SPIxCON1<4:2>) bits. The serial clock is output via the SCKx pin to slave devices. Clock pulses are only generated when there is data to be transmitted. For further information, refer to **Section 23.4 “Master Mode Clock Frequency”**. The CKP and CKE bits determine, on which edge of the clock, data transmission occurs.

Both data to be transmitted and data that is received are respectively written into, or read from, the SPIxBUF register.

The following describes the SPIx module operation in Master mode:

1. Once the module is set up for Master mode of operation and enabled, data to be transmitted is written to the SPIxBUF register. The SPITBF (SPIxSTAT<1>) bit is set.
2. The contents of SPIxTXB are moved to the shift register, SPIxSR, and the SPITBF bit is cleared by the module.
3. A series of 8/16 clock pulses shifts out 8/16 bits of transmit data from the SPIxSR to the SDOx pin and simultaneously shifts in the data at the SDIx pin into the SPIxSR.
4. When the transfer is complete, the following events will occur:
 - The interrupt flag bit, SPIxIF, is set. SPIx interrupts can be enabled by setting the interrupt enable bit, SPIxIE. The SPIxIF flag is not cleared automatically by the hardware.
 - Also, when the ongoing transmit and receive operation is completed, the contents of the SPIxSR are moved to the SPIxRXB register.
 - The SPIRBF (SPIxSTAT<0>) bit is set by the module, indicating that the receive buffer is full. Once the SPIxBUF register is read by the user code, the hardware clears the SPIRBF bit.
5. If the SPIRBF bit is set (receive buffer is full) when the SPIx module needs to transfer data from SPIxSR to SPIxRXB, the module will set the SPIROV (SPIxSTAT<6>) bit, indicating an overflow condition.
6. Data to be transmitted can be written to SPIxBUF by the user software at any time as long as the SPITBF (SPIxSTAT<1>) bit is clear. The write can occur while SPIxSR is shifting out the previously written data, allowing continuous transmission.

Note: The SPIxSR register cannot be written into directly by the user. All writes to the SPIxSR register are performed through the SPIxBUF register.

To set up the SPIx module for the Master mode of operation:

1. If using interrupts:
 - Clear the SPIxIF bit in the respective IFSn register.
 - Set the SPIxIE bit in the respective IECn register.
 - Write the SPIxIP bits in the respective IPCn register to set the interrupt priority.
2. Write the desired settings to the SPIxCON register with MSTEN (SPIxCON1<5>) = 1.
3. Clear the SPIROV bit (SPIxSTAT<6>).
4. Enable SPIx operation by setting the SPIEN bit (SPIxSTAT<15>).
5. Write the data to be transmitted to the SPIxBUF register. Transmission (and reception) will start as soon as data is written to the SPIxBUF register.

23.3.2.1.1 External Clocking in Master Mode

In Master mode, the module can also be configured to operate with an external data clock. SPIx clock operation is controlled by the DISSCK bit (SPIxCON1<12>). When this bit is set, the internal data clock is disabled and data is transferred when external clock pulses are presented on the SCKx pin. All other aspects of Master mode operation are the same as before.

Note: The DISSCK bit is available only in SPI Master modes.

Section 23. Serial Peripheral Interface (SPI)

Figure 23-3: SPIx Master Mode Timing

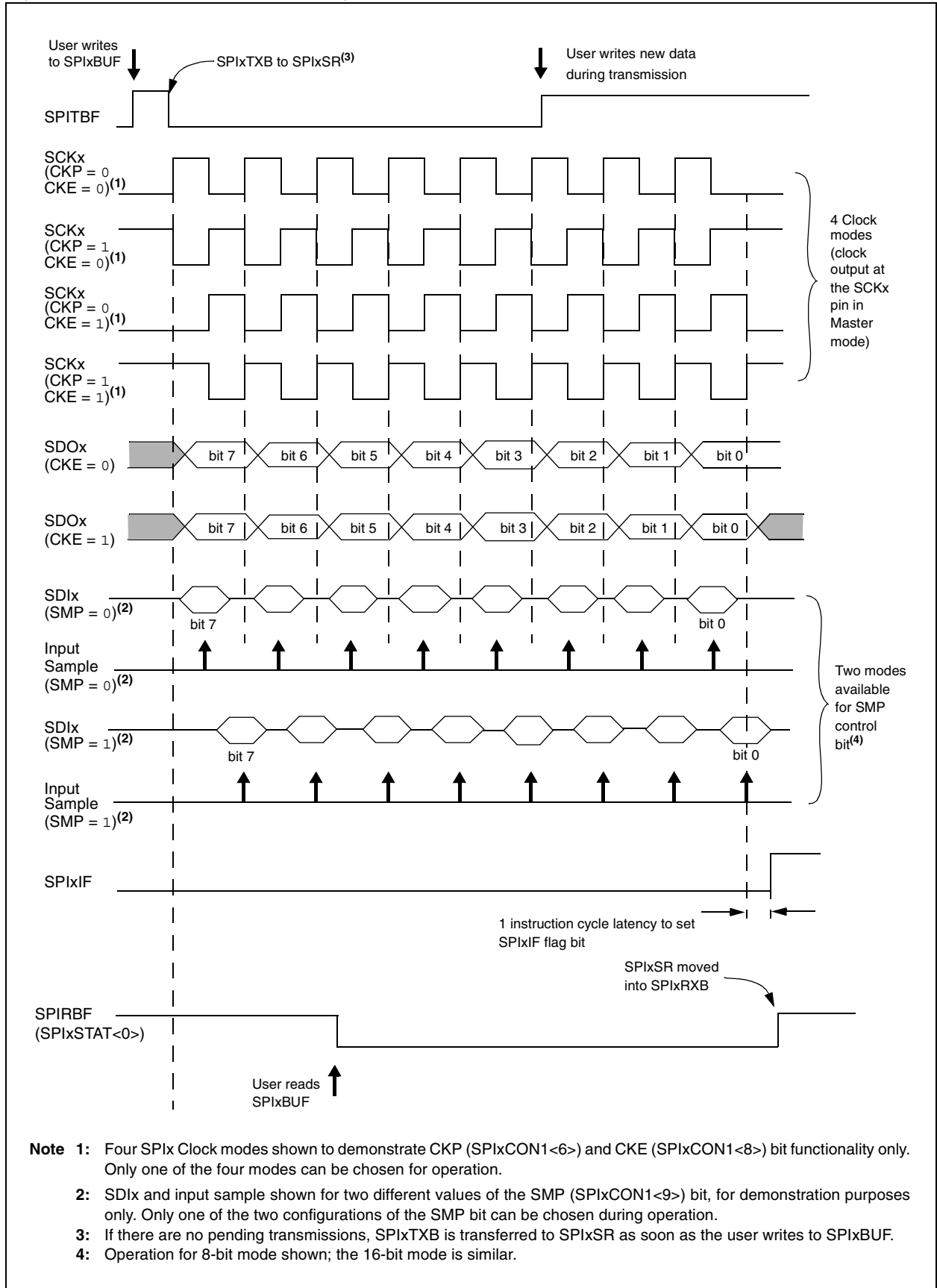

23.3.2.2 SLAVE MODE

In Slave mode, data is transmitted and received as the external clock pulses appear on the SCKx pin. The CKP (SPIxCON<6>) and CKE (SPIxCON<8>) bits determine on which edge of the clock data transmission occurs. Both data to be transmitted and data that is received are respectively written into or read from the SPIxBUF register. The rest of the operation of the module is identical to that in the Master mode.

To set up the SPIx module for the Slave mode of operation:

1. Clear the SPIxBUF register.
2. If using interrupts:
 - Clear the SPIxIF bit in the respective IFSn register.
 - Set the SPIxIE bit in the respective IECn register.
 - Write the SPIxIP bits in the respective IPCn register to set the interrupt priority.
3. Write the desired settings to the SPIxCON1 and SPIxCON2 registers with MSTEN (SPIxCON1<5>) = 0.
4. Clear the SMP bit.
5. If the CKE bit is set, then the SSEN bit (SPIxCON1<7>) must be set to enable the \overline{SSx} pin.
6. Clear the SPIROV bit (SPIxSTAT<6>).
7. Enable SPIx operation by setting the SPIEN bit (SPIxSTAT<15>).

23.3.2.2.1 Slave Select Synchronization

The \overline{SSx} pin allows a Synchronous Slave mode. If the SSEN (SPIxCON1<7>) bit is set, transmission and reception are enabled in Slave mode only if the \overline{SSx} pin is driven to a low state (see Figure 23-5). The port output or other peripheral outputs must not be driven in order to allow the \overline{SSx} pin to function as an input. If the SSEN bit is set and the \overline{SSx} pin is driven high, the SDOx pin is no longer driven and will tri-state even if the module is in the middle of a transmission. An aborted transmission will be retried the next time the \overline{SSx} pin is driven low, using the data held in the SPIxTXB register. If the SSEN bit is not set, the \overline{SSx} pin does not affect the module operation in Slave mode.

Note: To meet module timing requirements, the \overline{SSx} pin must be enabled in Slave mode when CKE = 1 (refer to Figure 23-6 for details).

23.3.2.2.2 SPITBF Status Flag Operation

The function of the SPITBF (SPIxSTAT<1>) bit is different in the Slave mode of operation.

If SSEN (SPIxCON1<7>) is cleared, the SPITBF is set when the SPIxBUF is loaded by the user code. It is cleared when the module transfers SPIxTXB to SPIxSR. This is similar to the SPITBF bit function in Master mode.

If SSEN is set, the SPITBF is set when the SPIxBUF is loaded by the user code. However, it is cleared only when the SPIx module completes data transmission. A transmission will be aborted when the \overline{SSx} pin goes high and may be retried at a later time. Each data word is held in SPIxTXB until all bits are transmitted to the receiver.

Section 23. Serial Peripheral Interface (SPI)

Figure 23-4: SPIx Slave Mode Timing (Slave Select Pin Disabled)⁽³⁾

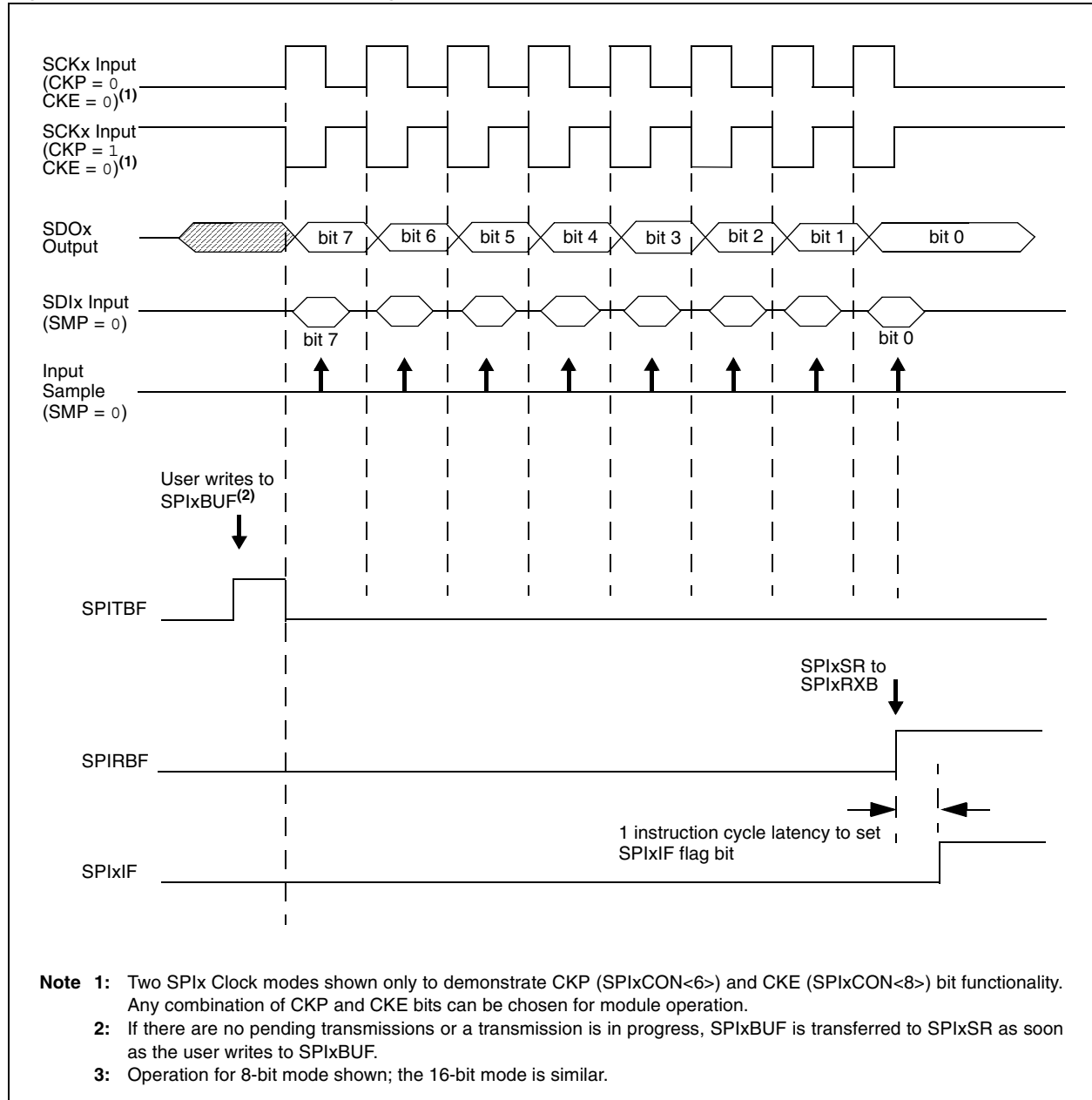

PIC24F Family Reference Manual

Figure 23-5: SPIx Slave Mode Timing (Slave Select Pin Enabled)⁽³⁾

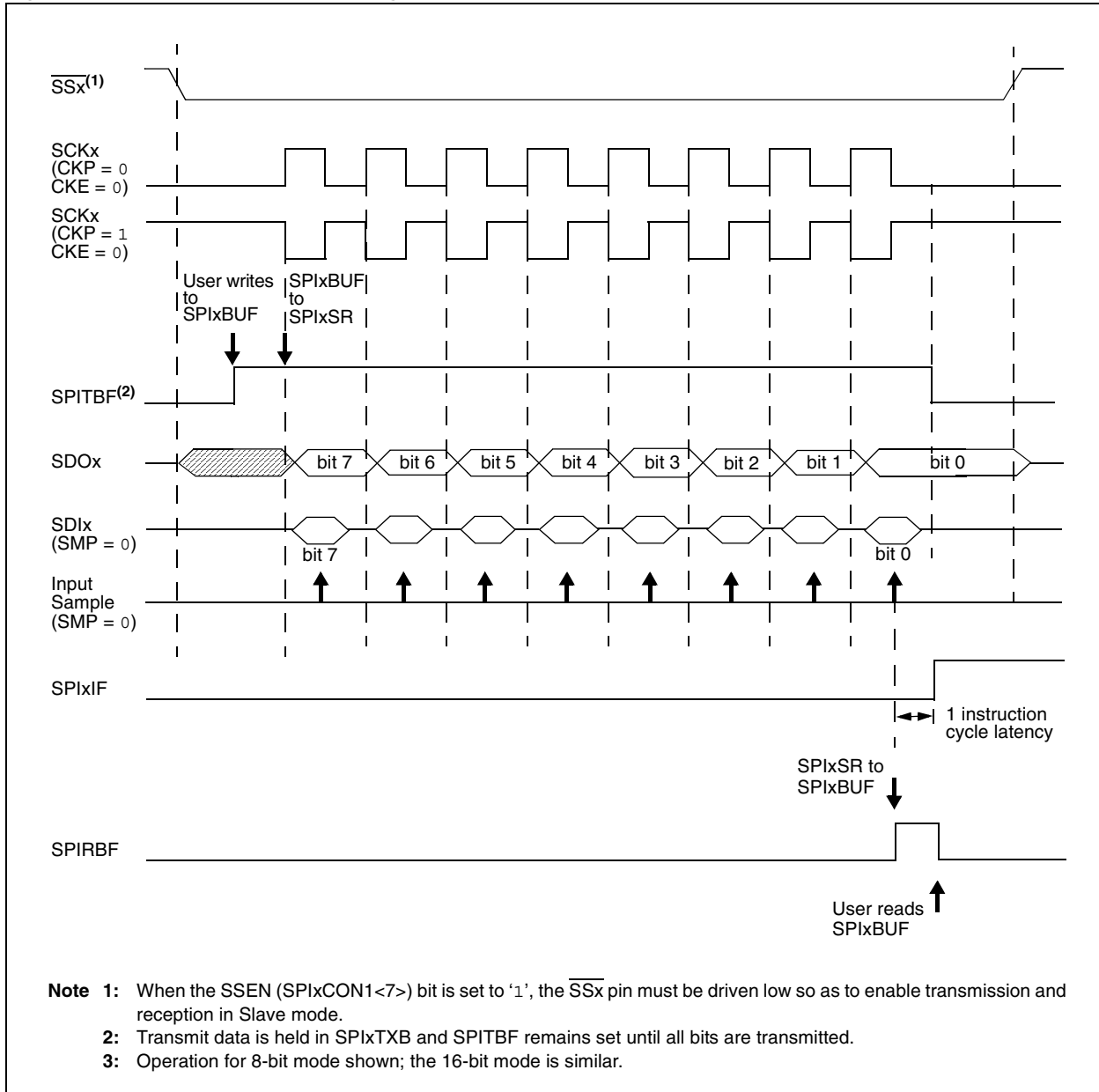

Section 23. Serial Peripheral Interface (SPI)

Figure 23-6: SPIx Slave Mode Timing (CKE = 1)⁽⁴⁾

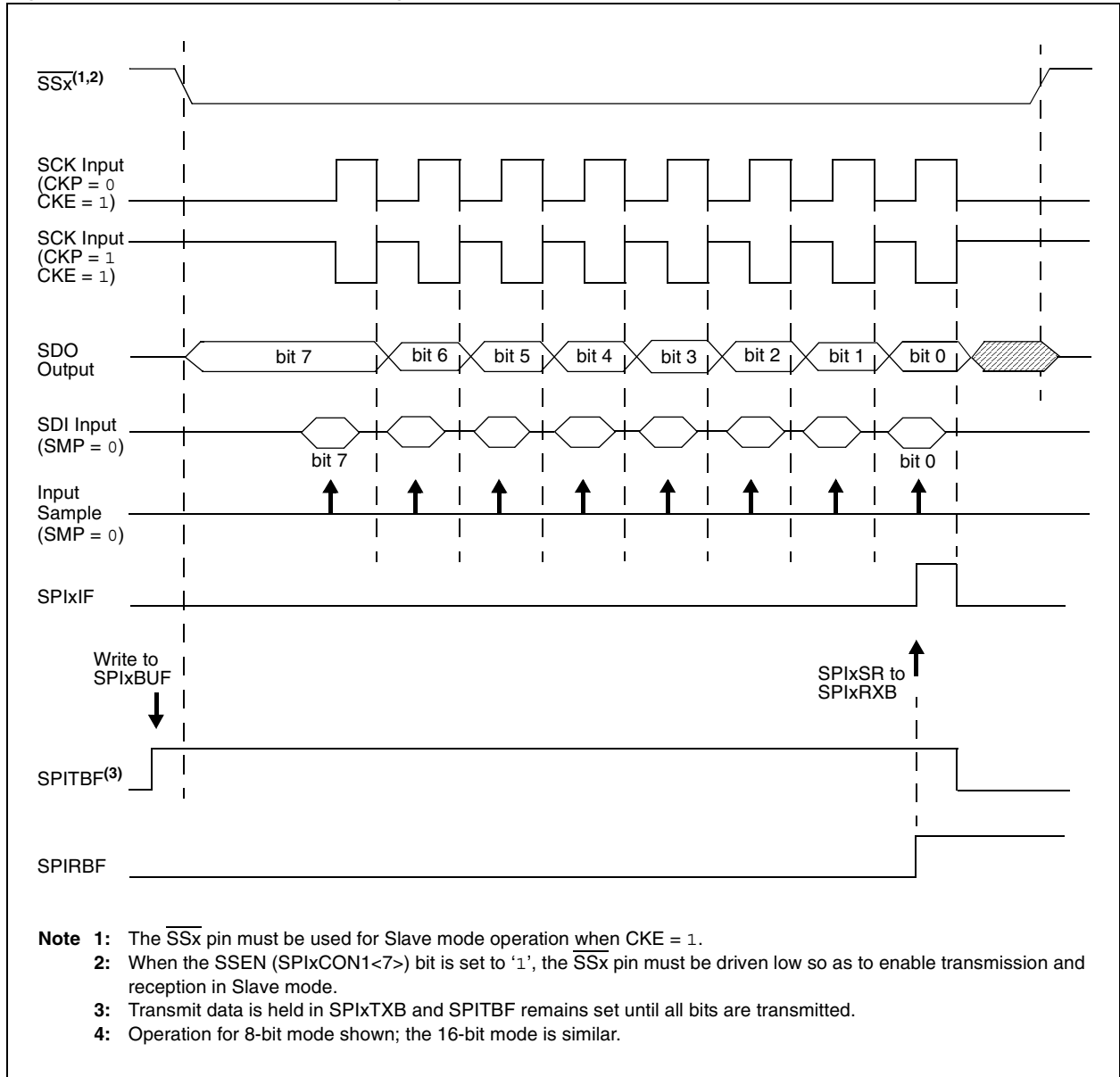

23.3.3 Framed SPIx Modes

The module supports a basic framed SPIx protocol while operating in either Master or Slave modes. The module uses four control bits to configure framed SPIx operation:

- FRMEN (SPIxCON2<15>) enables the Framed SPIx modes and causes the \overline{SSx} pin to be used as a frame synchronization pulse input or output pin. The state of SSEN (SPIxCON1<7>) is ignored.
- SPIFSD (SPIxCON2<14>) determines whether the \overline{SSx} pin is an input or an output (i.e., whether the module receives or generates the frame synchronization pulse).
- SPIFPOL (SPIxCON2<13>) selects the polarity of the frame synchronization pulse (active-high or active-low) for a single SPIx data frame.
- SPIFE (SPIxCON2<1>) selects the synchronization pulse to either coincide with, or precede, the first serial clock pulse.

The SPIx module supports two Framed modes of operation. In Framed Master mode, the SPIx module generates the frame synchronization pulse and provides this pulse to other devices at the $\overline{SSx}/FSYNCx$ pin. In Framed Slave mode, the SPIx module uses a frame synchronization pulse received at the $\overline{SSx}/FSYNCx$ pin.

Note: The use of the $\overline{SSx}/FSYNCx$ and SCKx pins are mandatory in all Framed SPIx modes.

The Framed SPIx modes are supported in conjunction with the unframed Master and Slave modes. This makes four framed SPIx configurations available to the user:

- SPIx Master Mode and Framed Master Mode
- SPIx Master Mode and Framed Slave Mode
- SPIx Slave Mode and Framed Master Mode
- SPIx Slave Mode and Framed Slave Mode

These modes determine whether or not the SPIx module generates the serial clock and the frame synchronization pulse.

23.3.3.1 SCKx PIN IN FRAMED SPIx MODES

When FRMEN = 1 and MSTEN = 1, the SCKx pin becomes an output and the SPIx clock at SCKx becomes a free-running clock. When FRMEN = 1 and MSTEN = 0, the SCKx pin becomes an input. The source clock provided to the SCKx pin is assumed to be a free-running clock.

The polarity of the clock is selected by the CKP (SPIxCON1<6>) bit. The CKE (SPIxCON1<8>) bit is not used for the Framed SPIx modes and should be programmed to '0' by the user software. When CKP = 0, the frame sync pulse output and the SDOx data output change on the rising edge of the clock pulses at the SCKx pin. Input data is sampled at the SDIx input pin on the falling edge of the serial clock. When CKP = 1, the frame sync pulse output and the SDOx data output change on the falling edge of the clock pulses at the SCKx pin. Input data is sampled at the SDIx input pin on the rising edge of the serial clock.

23.3.3.2 SPIx IN FRAMED SPIx MODES

When SPIFSD (SPIxCON2<13>) = 0, the SPIx module is in the Framed Master mode of operation. In this mode, the frame sync pulse is initiated by the module when the user software writes the transmit data to the SPIxBUF location (thus writing the SPIxTXB register with transmit data). At the end of the frame sync pulse, the SPIxTXB is transferred to the SPIxSR and data transmission/reception begins.

When SPIFSD = 1, the module is in Framed Slave mode. In this mode, the frame sync pulse is generated by an external source. When the module samples the frame sync pulse, it will transfer the contents of the SPIxTXB register to the SPIxSR and data transmission/reception begins. The user must make sure that the correct data is loaded into the SPIxBUF for transmission before the frame sync pulse is received.

Note: Receiving a frame sync pulse will start a transmission, regardless of whether data was written to SPIxBUF. If no write was performed, the old contents of the SPIxTXB will be transmitted.

Section 23. Serial Peripheral Interface (SPI)

23.3.3.3 SPIx MASTER MODE AND FRAMED MASTER MODE

In Master/Framed Master mode, the SPIx module generates both the clock and frame synchronization signals, as shown in Figure 23-7. It is enabled by setting the MSTEN and FRMEN bits to '1' and the SPIFSD bit to '0'.

In this mode, the serial clock is output continuously at the SCKx pin, regardless of whether the module is transmitting. When SPIxBUF is written, the FSYNCx pin will be driven to its active state (as determined by the SPIFPOL bit) on the appropriate transmit edge of the SCKx clock, and remain active for one data frame. If the SPIFE control bit (SPIxCON2<1>) is cleared, the frame sync pulse precedes the data transmission, as shown in Figure 23-8. If SPIFE is set, the frame sync pulse coincides with the beginning of the data transmission, as shown in Figure 23-9. The module starts transmitting data on the next transmit edge of the SCKx.

Figure 23-7: SPIx Master, Framed Master Connection Diagram

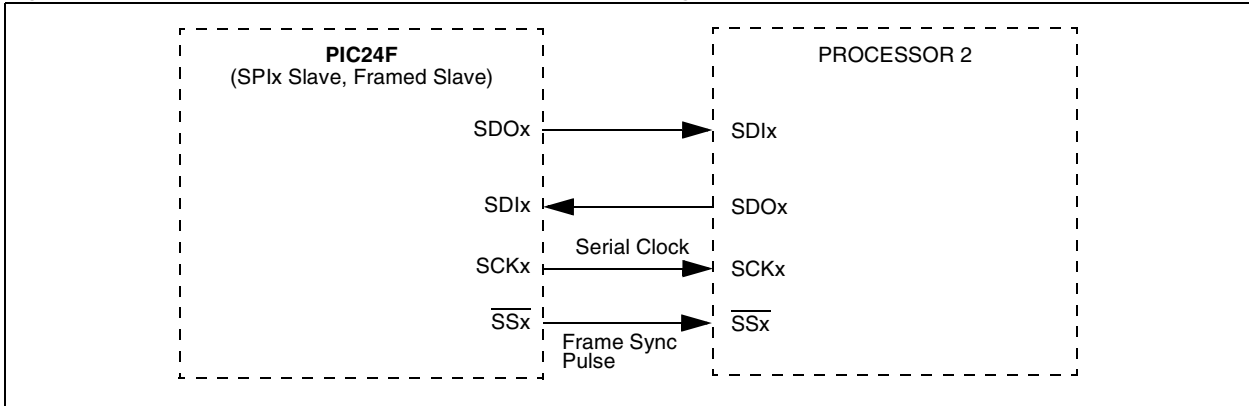

Figure 23-8: SPIx Master, Framed Master Timing (SPIFE = 0)

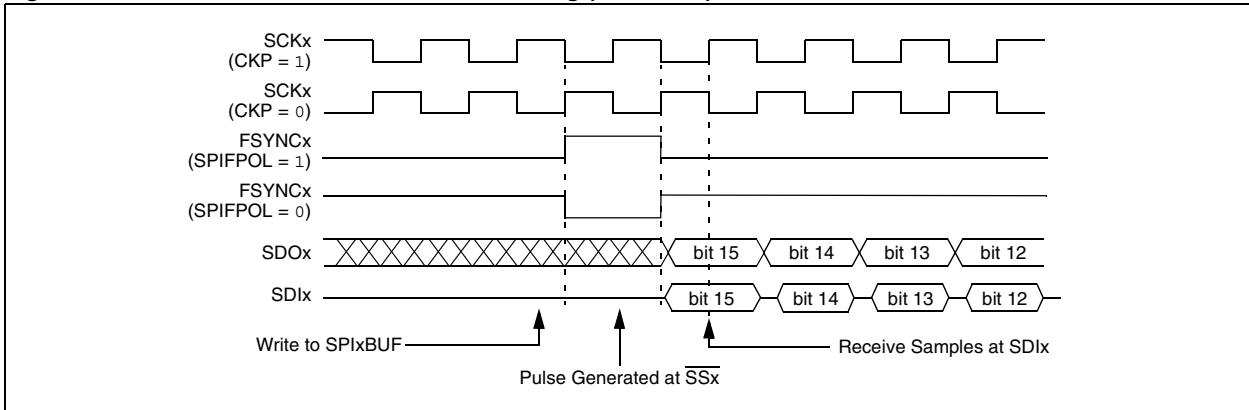
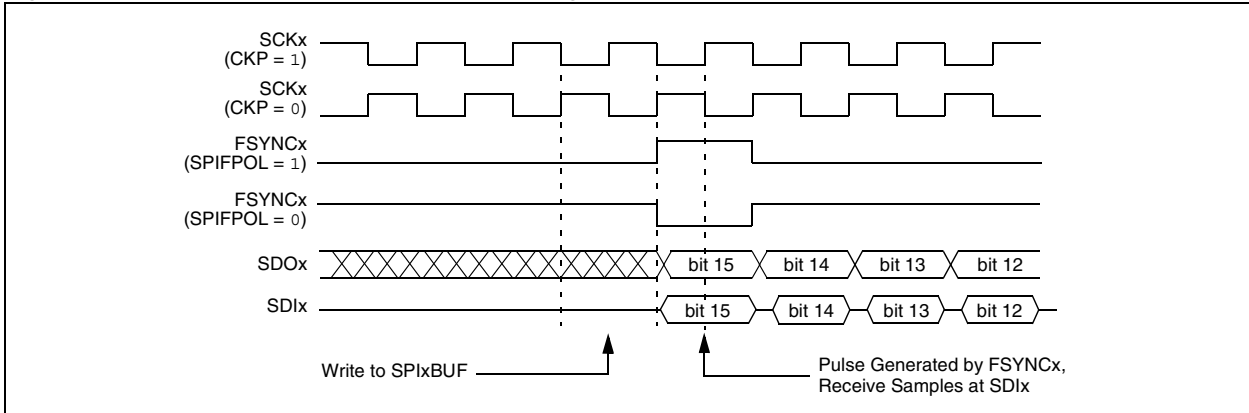

Figure 23-9: SPIx Master, Framed Master Timing (SPIFE = 1)



PIC24F Family Reference Manual

23.3.3.4 SPIx MASTER MODE AND FRAMED SLAVE MODE

In Master/Framed Slave mode, the module generates the clock signal but uses the slave module's frame synchronization signal for data transmission (Figure 23-10). It is enabled by setting the MSTEN, FRMEN and SPIFSD bits to '1'.

In this mode, the FSYNCx pin is an input and it is sampled on the sample edge of the SPIx clock. When it is sampled in its active state, data will be transmitted on the subsequent transmit edge of the SPIx clock. The interrupt flag, SPIxIF, is set when the transmission is complete. The user must make sure that the correct data is loaded into the SPIxBUF for transmission before the signal is received at the FSYNCx pin.

Figure 23-10: SPIx Master, Framed Slave Connection Diagram

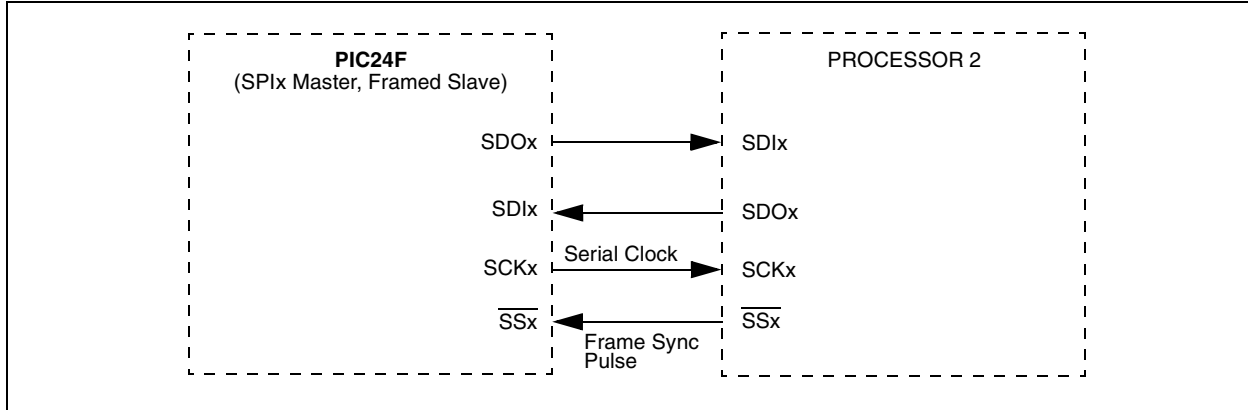

Figure 23-11: SPIx Master, Framed Slave Timing (SPIFE = 0)

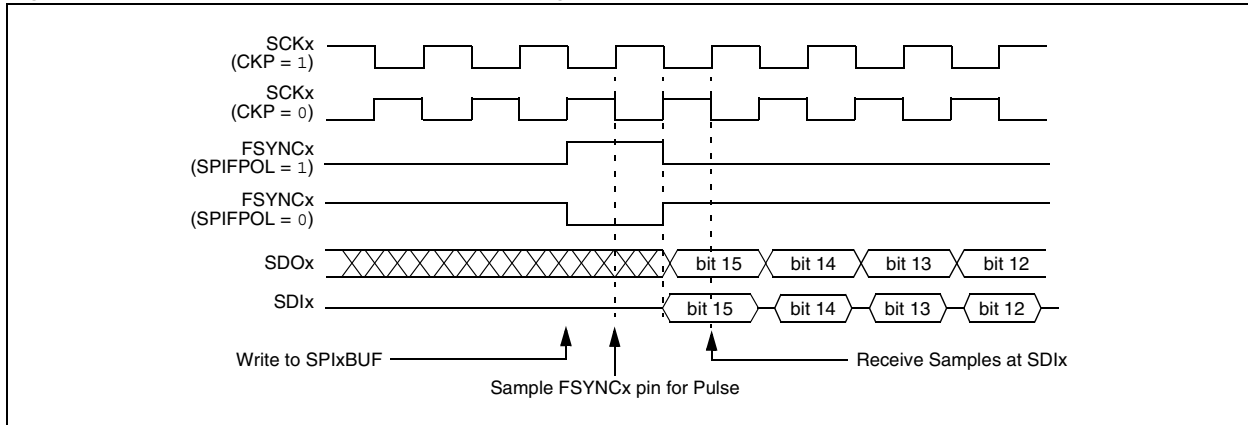
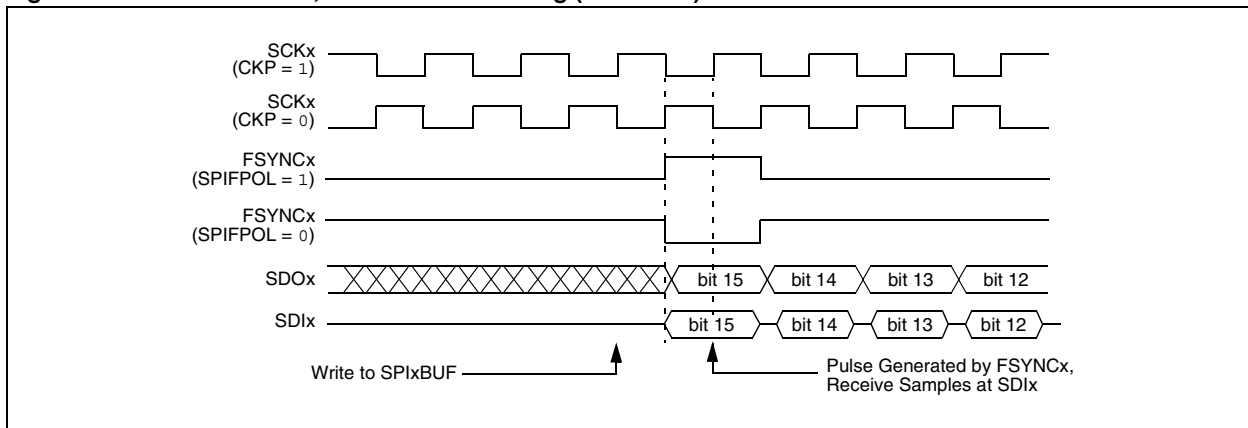

Figure 23-12: SPIx Master, Framed Slave Timing (SPIFE = 1)



Section 23. Serial Peripheral Interface (SPI)

23.3.3.5 SPIx SLAVE MODE AND FRAMED MASTER MODE

In Slave/Framed Master mode, the module acts as the SPIx slave and takes its clock from the other SPIx module; however, it produces frame synchronization signals to control data transmission (Figure 23-13). It is enabled by setting the MSTEN bit to '0', the FRMEN bit to '1' and the SPIFSD bit to '0'.

The input SPIx clock will be continuous in Slave mode. The FSYNCx pin will be an output when the SPIFSD bit is low. Therefore, when the SPIxBUF is written, the module drives the FSYNCx pin to the active state on the appropriate transmit edge of the SPIx clock for one SPIx clock cycle. Data will start transmitting on the appropriate SPIx clock transmit edge.

Figure 23-13: SPIx Slave, Framed Master Connection Diagram

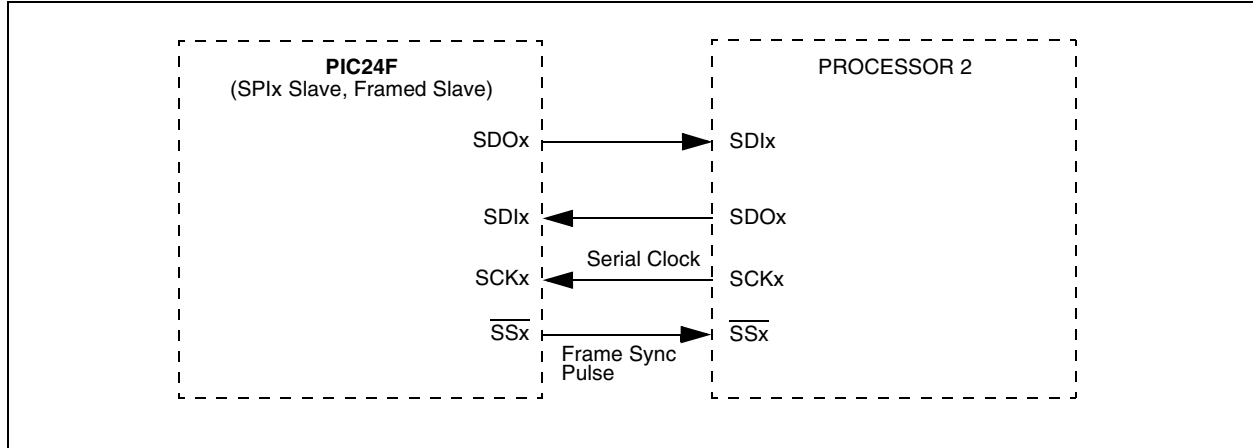

23.3.3.6 SPIx SLAVE MODE AND FRAMED SLAVE MODE

In Slave/Framed Slave mode, the module obtains both its clock and frame synchronization signal from the master module (Figure 23-14). It is enabled by setting MSTEN to '0', FRMEN to '1' and SPIFSD to '1'.

In this mode, both the SCKx and FSYNCx pins will be inputs. The FSYNCx pin is sampled on the sample edge of the SPIx clock. When FSYNCx is sampled at its active state, data will be transmitted on the appropriate transmit edge of SCKx.

Figure 23-14: SPIx Slave, Framed Slave Connection Diagram

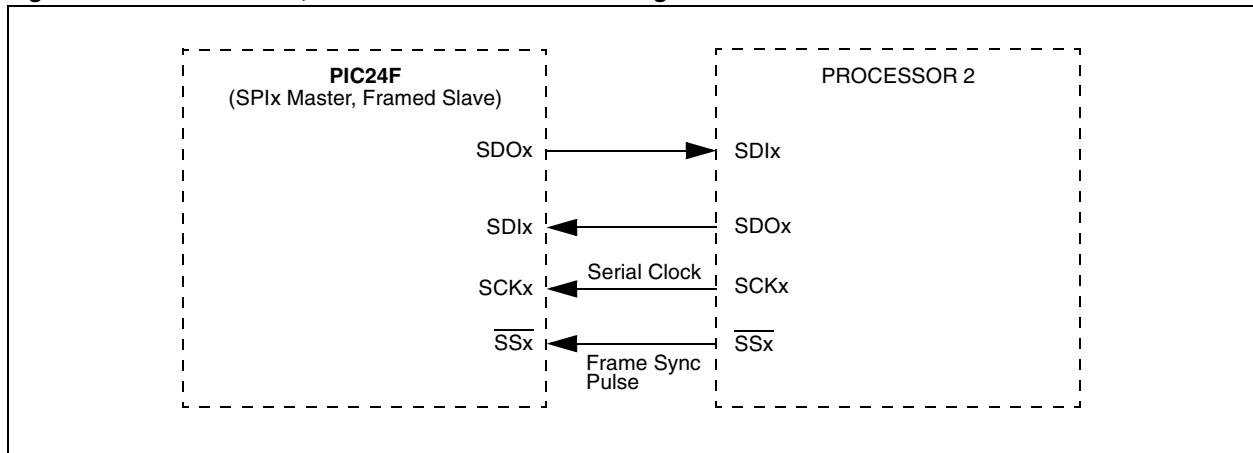

23.3.4 SPIx Receive Only Operation

Setting the DISSDO control bit (SPIxCON1<11>) disables transmission at the SDOx pin. This allows the SPIx module to be configured for a Receive Only mode of operation. The SDOx pin will be controlled by the respective port function if the DISSDO bit is set.

The DISSDO function is applicable to all SPIx operating modes.

23.3.5 SPIx Error Handling

If a new data word has been shifted into SPIxSR and the previous SPIxBUF contents have not been read, the SPIROV bit (SPIxSTAT<6>) will be set. Any received data in SPIxSR will not be transferred and further data reception is disabled until the SPIROV bit is cleared. The SPIROV bit is not cleared automatically by the module; it must be cleared by the user software.

The SPIx Interrupt Flag, SPIxIF, is set whenever the SPIROV, SPIRBF (SPIxSTAT<0>) or SPITBF (SPIxSTAT<1>) bits are set. The interrupt flag cannot be cleared by hardware and must be reset in software. The actual SPIx interrupt is generated only when the corresponding SPIxIE bit is set in the IECn Control register

23.4 MASTER MODE CLOCK FREQUENCY

In the Master mode, the clock provided to the SPIx module is the instruction cycle (Tcy). This clock will then be prescaled by the primary prescaler, specified by PPRE1:PPRE0 (SPIxCON1<1:0>), and the secondary prescaler, specified by SPRE2:SPRE0 (SPIxCON1<4:2>). The prescaled instruction clock becomes the serial clock and is provided to external devices via the SCKx pin.

Note: Note that the SCKx signal clock is not free running for normal SPI modes. It will only run for 8 or 16 pulses when the SPIxBUF is loaded with data. It will, however, be continuous for Framed modes.

Equation 23-1 can be used to calculate the SCKx clock frequency as a function of the primary and secondary prescaler settings.

Equation 23-1:

$$F_{SCK} = \frac{F_{CY}}{\text{Primary Prescaler} * \text{Secondary Prescaler}}$$

Some sample SPIx clock frequencies (in kHz) are shown in Table 23-1 below:

Table 23-1: Sample SCKx Frequencies^(1,2)

Fcy = 16 MHz		Secondary Prescaler Settings				
		1:1	2:1	4:1	6:1	8:1
Primary Prescaler Settings	1:1	16000	8000	4000	2667	2000
	4:1	4000	2000	1000	667	500
	16:1	1000	500	250	167	125
	64:1	250	125	63	42	31
Fcy = 5 MHz						
Primary Prescaler Settings	1:1	5000	2500	1250	833	625
	4:1	1250	625	313	208	156
	16:1	313	156	78	52	39
	64:1	78	39	20	13	10

Note 1: Based on Tcy = TOSC/2, Doze mode and PLL are disabled.
2:SCKx frequencies shown in kHz.

Note: Not all clock rates are supported. For further information, refer to the SPIx timing specifications in the specific device data sheet.

23.5 OPERATION IN POWER-SAVING MODES

The PIC24F family of devices has three Power modes: the normal operational (Full-Power) mode, and the two Power-Saving modes invoked by the `PWRSVAV` instruction. Depending on the SPIx mode selected, entering a Power-Saving mode may also affect the operation of the module.

23.5.1 Sleep Mode

When the device enters Sleep mode, the system clock is disabled. The consequences of entering Sleep depend on which mode (Master or Slave) the module is configured in at the time that Sleep mode is invoked.

23.5.1.1 MASTER MODE OPERATION

The following are a consequence of entering Sleep mode when the SPIx module is configured for master operation:

- The Baud Rate Generator in the SPIx module stops and is reset.
- The transmitter and receiver will stop in Sleep. The transmitter or receiver does not continue with a partially completed transmission at wake-up.
- If the SPIx module enters Sleep mode in the middle of a transmission or reception, the transmission or reception is aborted. Since there is no automatic way to prevent an entry into Sleep mode if a transmission or reception is pending, the user software must synchronize entry into Sleep with SPIx module operation to avoid aborted transmissions.

23.5.1.2 SLAVE MODE OPERATION

Since the clock pulses at SCKx are externally provided for Slave mode, the module will continue to function in Sleep mode. It will complete any transactions during the transition into Sleep. On completion of a transaction, the SPIRBF flag is set. Consequently, the SPIxIF bit will be set. If SPIx interrupts are enabled (`SPIxIE = 1`), the device will wake from Sleep. If the SPIx interrupt priority level is greater than the present CPU priority level, code execution will resume at the SPIx interrupt vector location. Otherwise, code execution will continue with the instruction following the `PWRSVAV` instruction that previously invoked Sleep mode. The module is not reset on entering Sleep mode if it is operating as a slave device.

Register contents are not affected when the SPIx module is going into or coming out of Sleep mode.

23.5.2 Idle Mode

When the device enters Idle mode, the system clock sources remain functional. The SPISIDL bit (`SPIxSTAT<13>`) selects whether the module will stop or continue functioning on Idle.

If `SPISIDL = 1`, the SPIx module will stop communication on entering Idle mode. It will operate in the same manner as it does in Sleep mode. If `SPISIDL = 0` (default selection), the module will continue operation in Idle mode.

23.6 REGISTER MAPS

A summary of the registers associated with the PIC24F SPI module is provided in Table 23-2.

Table 23-2: SPI Memory Map

Name	Bit 15	Bit 14	Bit 13	Bit 12	Bit 11	Bit 10	Bit 9	Bit 8	Bit 7	Bit 6	Bit 5	Bit 4	Bit 3	Bit 2	Bit 1	Bit 0	All Resets
SPIxSTAT	SPIEN	—	SPI/SIDL	—	—	r	r	r	—	SPIROV	—	—	—	—	SPI/TBF	SPIRBF	0000
SPIxCON1	—	—	—	DISSCK	DISSDO	MODE16	SMP	CKE	SSEN	CKP	MSTEN	SPRE2	SPRE1	—	PPRE1	PPRE0	0000
SPIxCON2	FRMEN	SPIFSD	SPIFPOL	—	—	—	—	—	—	—	—	—	—	—	SPIFE	r	0000
SPIxBUF	SPIx Transmit and Receive Buffer																
PMD1	T5MD	T4MD	T3MD	T2MD	T1MD	—	—	—	I2C1MD	U2MD	U1MD	SPI2MD	SPI1MD	—	—	ADCMD	0000
PMD2	—	—	—	IC5MD	IC4MD	IC3MD	IC2MD	IC1MD	—	—	—	OC5MD	OC4MD	OC3MD	OC2MD	OC1MD	0000
PMD3	—	—	—	—	—	CMPMD	RTCCMD	PMPMD	CRCPMD	—	—	—	—	—	I2CMD	—	0000

Legend: — = unimplemented, read as '0'. Reset values are shown in hexadecimal.

23.7 ELECTRICAL SPECIFICATIONS

Figure 23-15: SPIx Module Master Mode Timing Characteristics (CKE = 0)

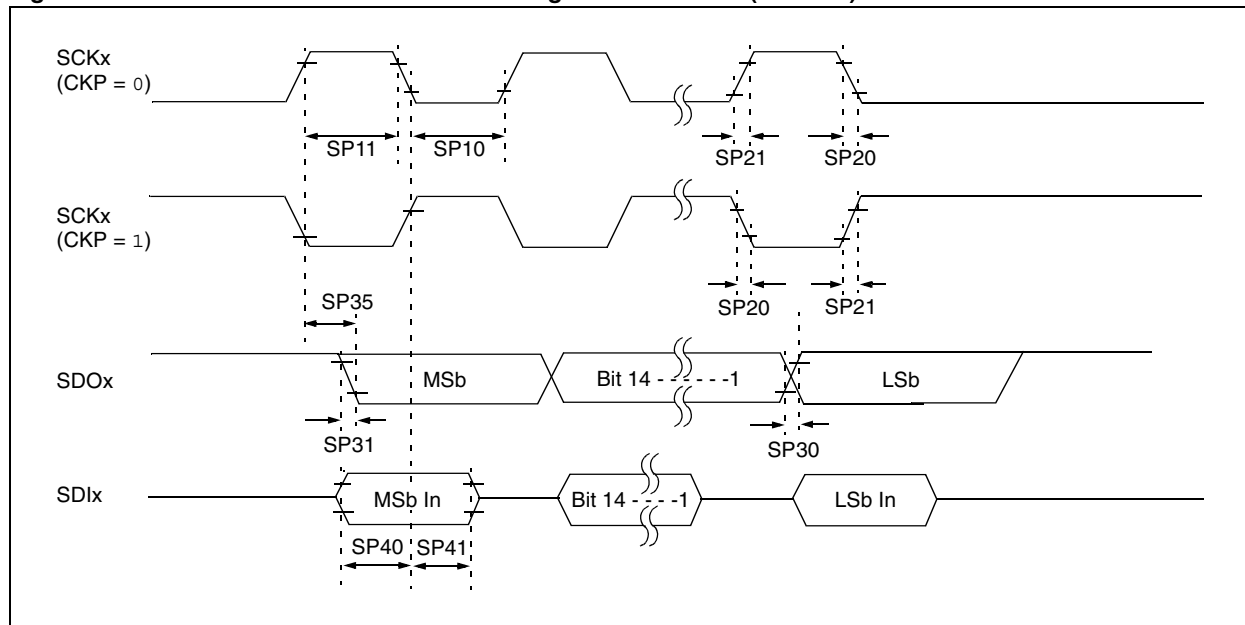

Table 23-3: SPIx Master Mode Timing Requirements (CKE = 0)

AC CHARACTERISTICS			Standard Operating Conditions: 2.0V to 3.6V (unless otherwise stated) Operating temperature $-40^{\circ}\text{C} \leq T_A \leq +85^{\circ}\text{C}$ for Industrial				
Param No.	Symbol	Characteristic	Min	Typ ⁽¹⁾	Max	Units	Conditions
SP10	TscL	SCKx Output Low Time ⁽²⁾	$T_{CY}/2$	—	—	ns	
SP11	TscH	SCKx Output High Time ⁽²⁾	$T_{CY}/2$	—	—	ns	
SP20	TscF	SCKx Output Fall Time ⁽³⁾	—	10	25	ns	
SP21	TscR	SCKx Output Rise Time ⁽³⁾	—	10	25	ns	
SP30	TdoF	SDOx Data Output Fall Time ⁽³⁾	—	10	25	ns	
SP31	TdoR	SDOx Data Output Rise Time ⁽³⁾	—	10	25	ns	
SP35	Tsch2doV, TscL2doV	SDOx Data Output Valid after SCKx Edge	—	—	30	ns	
SP40	TdiV2scH, TdiV2scL	Setup Time of SDIx Data Input to SCKx Edge	20	—	—	ns	
SP41	Tsch2diL, TscL2diL	Hold Time of SDIx Data Input to SCKx Edge	20	—	—	ns	

Note 1: Data in “Typ” column is at 3.3V, 25°C unless otherwise stated. Parameters are for design guidance only and are not tested.

2: The minimum clock period for SCKx is 100 ns. Therefore, the clock generated in Master mode must not violate this specification.

3: Assumes 50 pF load on all SPI pins.

PIC24F Family Reference Manual

Figure 23-16: SPIx Module Master Mode Timing Characteristics (CKE = 1)

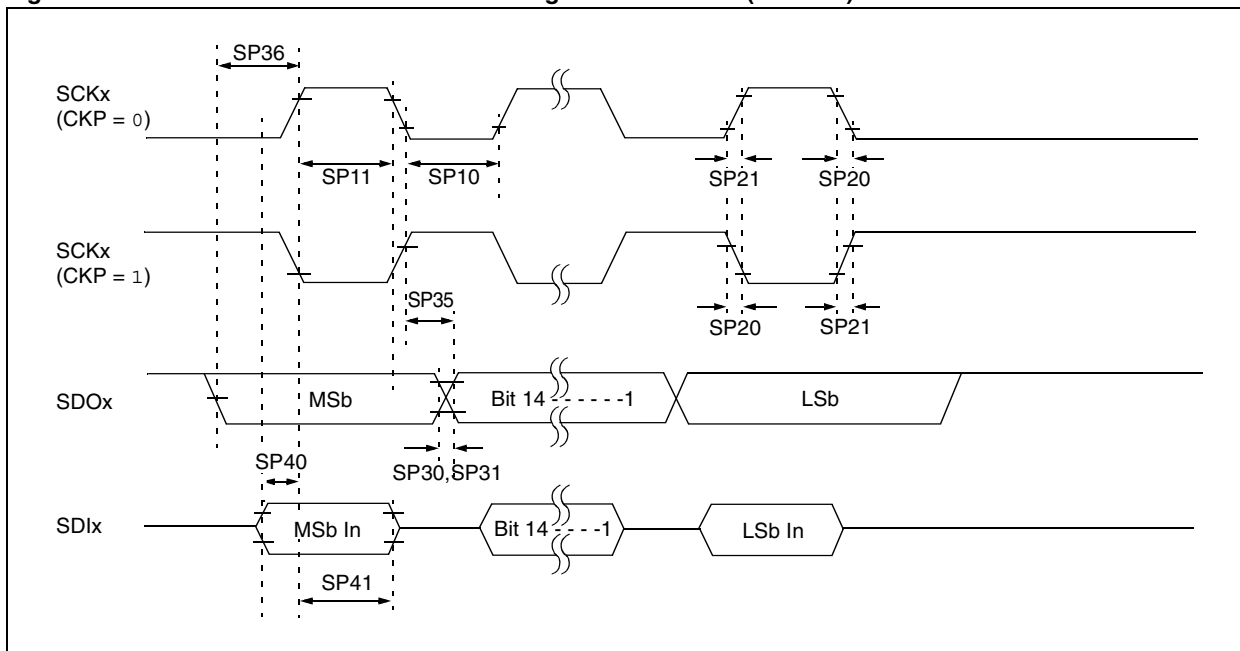

Table 23-4: SPIx Module Master Mode Timing Requirements (CKE = 1)

AC CHARACTERISTICS			Standard Operating Conditions: 2.0V to 3.6V (unless otherwise stated) Operating temperature $-40^{\circ}\text{C} \leq T_A \leq +85^{\circ}\text{C}$ for Industrial				
Param No.	Symbol	Characteristic	Min	Typ ⁽¹⁾	Max	Units	Conditions
SP10	TscL	SCKx Output Low Time ⁽²⁾	$T_{CY}/2$	—	—	ns	
SP11	Tsch	SCKx Output High Time ⁽²⁾	$T_{CY}/2$	—	—	ns	
SP20	TscF	SCKx Output Fall Time ⁽³⁾	—	10	25	ns	
SP21	TscR	SCKx Output Rise Time ⁽³⁾	—	10	25	ns	
SP30	TdoF	SDOx Data Output Fall Time ⁽³⁾	—	10	25	ns	
SP31	TdoR	SDOx Data Output Rise Time ⁽³⁾	—	10	25	ns	
SP35	Tsch2doV, TscL2doV	SDOx Data Output Valid after SCKx Edge	—	—	30	ns	
SP36	TdoV2sc, TdoV2scL	SDOx Data Output Setup to First SCKx Edge	30	—	—	ns	
SP40	TdiV2sch, TdiV2scL	Setup Time of SDIx Data Input to SCKx Edge	20	—	—	ns	
SP41	Tsch2diL, TscL2diL	Hold Time of SDIx Data Input to SCKx Edge	20	—	—	ns	

Note 1: Data in "Typ" column is at 3.3V, 25°C unless otherwise stated. Parameters are for design guidance only and are not tested.

2: The minimum clock period for SCKx is 100 ns. Therefore, the clock generated in Master mode must not violate this specification.

3: Assumes 50 pF load on all SPI pins.

Section 23. Serial Peripheral Interface (SPI)

Figure 23-17: SPIx Module Slave Mode Timing Characteristics (CKE = 0)

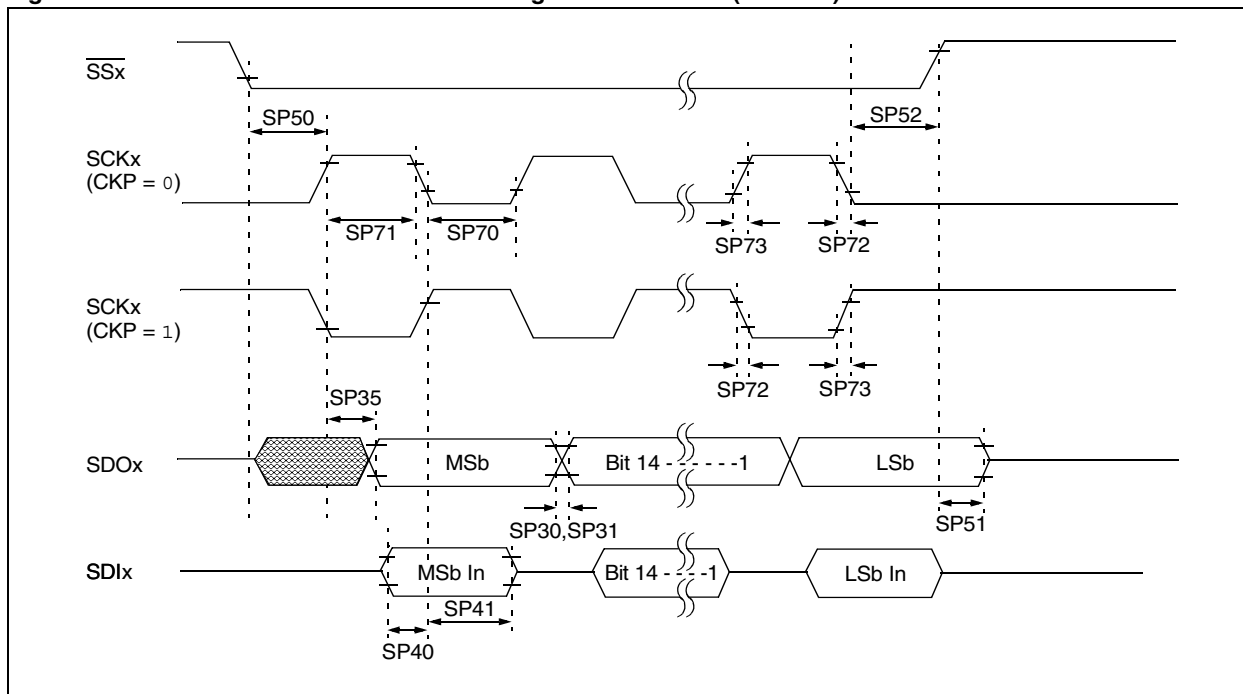

Table 23-5: SPIx Module Slave Mode Timing Requirements (CKE = 0)

AC CHARACTERISTICS			Standard Operating Conditions: 2.0V to 3.6V (unless otherwise stated) Operating temperature $-40^{\circ}\text{C} \leq T_A \leq +85^{\circ}\text{C}$ for Industrial				
Param No.	Symbol	Characteristic	Min	Typ ⁽¹⁾	Max	Units	Conditions
SP70	TscL	SCKx Input Low Time	30	—	—	ns	
SP71	TschH	SCKx Input High Time	30	—	—	ns	
SP72	TscF	SCKx Input Fall Time ⁽²⁾	—	10	25	ns	
SP73	TscR	SCKx Input Rise Time ⁽²⁾	—	10	25	ns	
SP30	TdoF	SDOx Data Output Fall Time ⁽²⁾	—	10	25	ns	
SP31	TdoR	SDOx Data Output Rise Time ⁽²⁾	—	10	25	ns	
SP35	Tsch2doV, TscL2doV	SDOx Data Output Valid after SCKx Edge	—	—	30	ns	
SP40	TdiV2scH, TdiV2scL	Setup Time of SDIx Data Input to SCKx Edge	20	—	—	ns	
SP41	Tsch2diL, TscL2diL	Hold Time of SDIx Data Input to SCKx Edge	20	—	—	ns	
SP50	TssL2scH, TssL2scL	$\overline{\text{SSx}}$ to SCKx \uparrow or SCKx Input	120	—	—	ns	
SP51	TssH2doZ	$\overline{\text{SSx}}\uparrow$ to SDOx Output High-Impedance ⁽³⁾	10	—	50	ns	
SP52	Tsch2ssH, TscL2ssH	$\overline{\text{SSx}}$ after SCKx Edge	$1.5 T_{CY} + 40$	—	—	ns	

Note 1: Data in "Typ" column is at 3.3V, 25°C unless otherwise stated. Parameters are for design guidance only and are not tested.

2: Assumes 50 pF load on all SPI pins.

PIC24F Family Reference Manual

Figure 23-18: SPIx Module Slave Mode Timing Characteristics (CKE = 1)

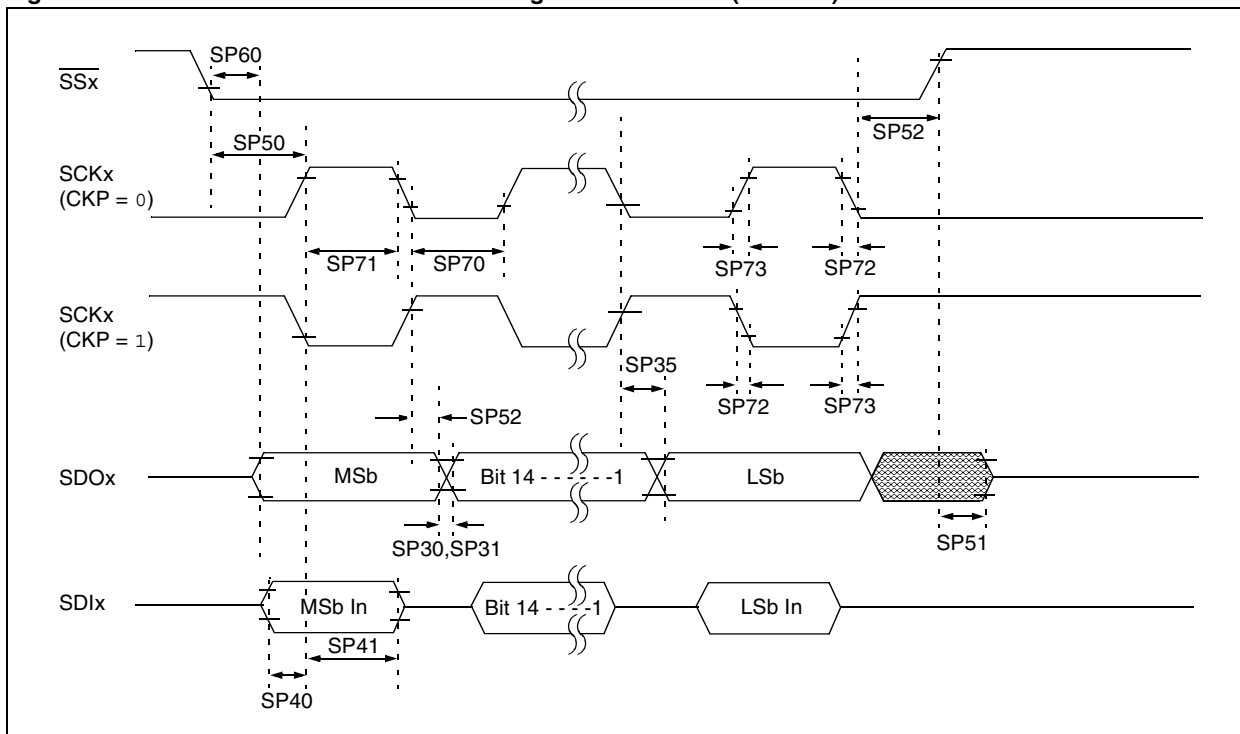

Table 23-6: SPIx Module Slave Mode Timing Requirements (CKE = 1)

AC CHARACTERISTICS			Standard Operating Conditions: 2.0V to 3.6V (unless otherwise stated) Operating temperature $-40^{\circ}\text{C} \leq T_A \leq +85^{\circ}\text{C}$ for Industrial				
Param No.	Symbol	Characteristic	Min	Typ ⁽¹⁾	Max	Units	Conditions
SP70	TscL	SCKx Input Low Time	30	—	—	ns	
SP71	TscH	SCKx Input High Time	30	—	—	ns	
SP72	TscF	SCKx Input Fall Time ⁽²⁾	—	10	25	ns	
SP73	TscR	SCKx Input Rise Time ⁽²⁾	—	10	25	ns	
SP30	TdoF	SDOx Data Output Fall Time ⁽²⁾	—	10	25	ns	
SP31	TdoR	SDOx Data Output Rise Time ⁽²⁾	—	10	25	ns	
SP35	Tsch2doV, TscL2doV	SDOx Data Output Valid after SCKx Edge	—	—	30	ns	
SP40	TdiV2scH, TdiV2scL	Setup Time of SDIx Data Input to SCKx Edge	20	—	—	ns	
SP41	Tsch2diL, TscL2diL	Hold Time of SDIx Data Input to SCKx Edge	20	—	—	ns	
SP50	TssL2scH, TssL2scL	$\overline{\text{SSx}}\downarrow$ to SCKx \downarrow or SCKx \uparrow Input	120	—	—	ns	
SP51	TssH2doZ	$\overline{\text{SSx}}\uparrow$ to SDOx Output High-Impedance ⁽³⁾	10	—	50	ns	
SP52	Tsch2ssH, TscL2ssH	$\overline{\text{SSx}}\uparrow$ after SCKx Edge	$1.5 T_{CY} + 40$	—	—	ns	
SP60	TssL2doV	SDOx Data Output Valid after $\overline{\text{SSx}}$ Edge	—	—	50	ns	

Note 1: Data in "Typ" column is at 3.3V, 25°C unless otherwise stated. Parameters are for design guidance only and are not tested.

2: The minimum clock period for SCKx is 100 ns. Therefore, the clock generated in Master mode must not violate this specification.

3: Assumes 50 pF load on all SPI pins.

23.8 RELATED APPLICATION NOTES

This section lists application notes that are related to this section of the manual. These application notes may not be written specifically for the PIC24F device family, but the concepts are pertinent and could be used with modification and possible limitations. The current application notes related to the Serial Peripheral Interface (SPI) module are:

Title	Application Note #
Interfacing Microchip's MCP41XXX and MCP42XXX Digital Potentiometers to a PICmicro® Microcontroller	AN746
Interfacing Microchip's MCP3201 Analog-to-Digital Converter to the PICmicro® Microcontroller	AN719

Note: Please visit the Microchip web site (www.microchip.com) for additional application notes and code examples for the PIC24F family of devices.

23.9 REVISION HISTORY

Revision A (August 2006)

This is the initial released revision of this document.