



---

---

## Section 20. Comparator Voltage Reference Module

---

---

### HIGHLIGHTS

This section of the manual contains the following major topics:

20.1	Introduction .....	20-2
20.2	Configuring the Comparator Voltage Reference .....	20-3
20.3	Control Register .....	20-4
20.4	Voltage Reference Accuracy/Error .....	20-5
20.5	Operation During Sleep .....	20-5
20.6	Effects of a Reset .....	20-5
20.7	Connection Considerations .....	20-6
20.8	Initialization .....	20-6
20.9	Electrical Specifications .....	20-7
20.10	Design Tips .....	20-8
20.11	Related Application Notes .....	20-9
20.12	Revision History .....	20-10

# PIC24F Family Reference Manual

## 20.1 INTRODUCTION

The comparator voltage reference is a 16-tap, resistor ladder network that provides a selectable reference voltage. Although its primary purpose is to provide a reference for the analog comparators, it may also be used independently of them.

A block diagram of the module is shown in Figure 20-1. The resistor ladder is segmented to provide two ranges of voltage reference values and has a power-down function to conserve power when the reference is not being used. The module's supply reference can be provided from either device  $V_{DD}/V_{SS}$  or an external voltage reference. The CVREF output is available for the comparators and typically available for pin output. Please see the specific device data sheet for information.

Figure 20-1: Comparator Voltage Reference Block Diagram

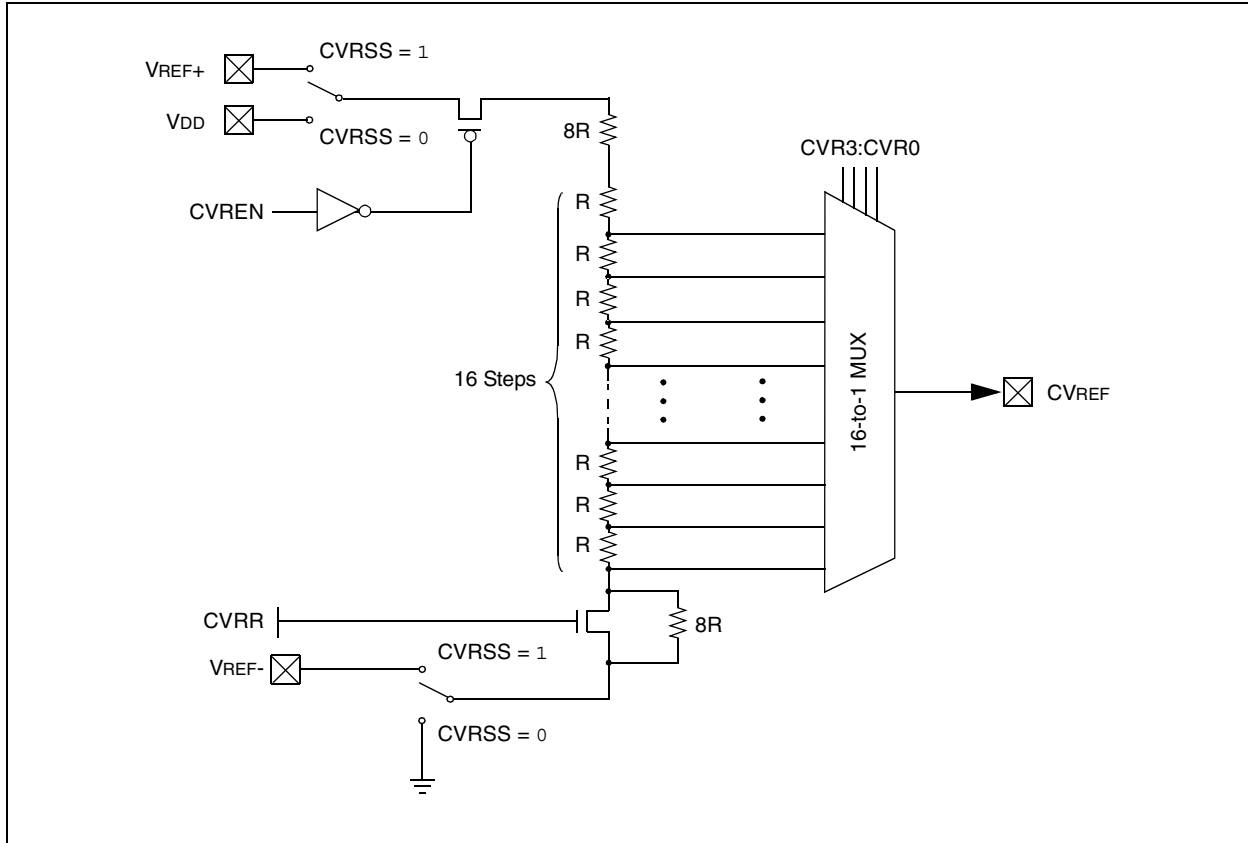

## Section 20. Comparator Voltage Reference Module

Table 20-1: Typical Voltage Reference with CVRSRC = 3.3V

CVR<3:0>	Voltage Reference	
	CVRR = 0	CVRR = 1
0	0.83V	0.00V
1	0.93V	0.14V
2	1.03V	0.28V
3	1.13V	0.41V
4	1.24V	0.55V
5	1.34V	0.69V
6	1.44V	0.83V
7	1.55V	0.96V
8	1.65V	1.10V
9	1.75V	1.24V
10	1.86V	1.38V
11	1.96V	1.51V
12	2.06V	1.65V
13	2.17V	1.79V
14	2.27V	1.93V
15	2.37V	2.06V

### 20.2 CONFIGURING THE COMPARATOR VOLTAGE REFERENCE

The comparator voltage reference module is controlled through the CVRCON register (Register 20-1). The comparator voltage reference provides two ranges of output voltage, each with 16 distinct levels. The range to be used is selected by the CVRR bit (CVRCON<5>). The primary difference between the ranges is the size of the steps selected by the Comparator Voltage Reference Value Selection bits, CVR3:CVR0, with one range offering finer resolution. The equations used to calculate the comparator voltage reference are as follows:

If CVRR = 1:

$$\text{Voltage Reference} = ((\text{CVR3:CVR0})/24) \times (\text{CVRSRC})$$

If CVRR = 0:

$$\text{Voltage Reference} = (\text{CVRSRC}/4) + ((\text{CVR3:CVR0})/32) \times (\text{CVRSRC})$$

The Comparator Voltage Reference Source Voltage (CVRSRC) can come from either VDD and VSS, or the external VREF+ and VREF- pins that are multiplexed with I/O pins. The voltage source is selected by the CVRSS bit (CVRCON<4>). The voltage reference is output to the CVREF pin by setting the CVROE (CVRCON<6>) bit; this will override the corresponding TRIS bit setting.

The settling time of the comparator voltage reference must be considered when changing the CVREF output (see **Section 20.9 “Electrical Specifications”**).

# PIC24F Family Reference Manual

## 20.3 CONTROL REGISTER

Register 20-1: CVRCON: Comparator Voltage Reference Control Register

U-0	U-0	U-0	U-0	U-0	U-0	U-0	U-0
—	—	—	—	—	—	—	—
bit 15							bit 8

R/W-0	R/W-0	R/W-0	R/W-0	R/W-0	R/W-0	R/W-0	R/W-0
CVREN	CVROE <sup>(1)</sup>	CVRR	CVRSS	CVR3	CVR2	CVR1	CVR0
bit 7							bit 0

**Legend:**

R = Readable bit                      W = Writable bit                      U = Unimplemented bit, read as '0'  
 -n = Value at POR                      '1' = Bit is set                      '0' = Bit is cleared                      x = Bit is unknown

- bit 15-8        **Unimplemented:** Read as '0'
- bit 7         **CVREN:** Comparator Voltage Reference Enable bit  
                  1 = Comparator voltage reference circuit powered on  
                  0 = Comparator voltage reference circuit powered down
- bit 6         **CVROE:** Comparator Voltage Reference Output Enable bit<sup>(1)</sup>  
                  1 = Voltage level is output on CVREF pin  
                  0 = Voltage level is disconnected from CVREF pin
- bit 5         **CVRR:** Comparator Voltage Reference Range Selection bit  
                  1 = 0 to 0.67 CVRSRC, with CVRSRC/24 step size  
                  0 = 0.25 CVRSRC to 0.75 CVRSRC, with CVRSRC/32 step size
- bit 4         **CVRSS:** Comparator Voltage Reference Source Selection bit  
                  1 = Comparator voltage reference source, CVRSRC = (VREF+) – (VREF-)  
                  0 = Comparator voltage reference source, CVRSRC = AVDD – AVSS
- bit 3-0       **CVR3:CVR0:** Comparator Voltage Reference Value Selection  $0 \leq \text{CVR3:CVR0} \leq 15$  bits  
                  When CVRR = 1:  
                   $\text{CVREF} = (\text{CVR}\langle 3:0 \rangle / 24) \cdot (\text{CVRSRC})$   
                  When CVRR = 0:  
                   $\text{CVREF} = 1/4 \cdot (\text{CVRSRC}) + (\text{CVR}\langle 3:0 \rangle / 32) \cdot (\text{CVRSRC})$

**Note 1:** CVROE overrides the TRIS bit setting.

## Section 20. Comparator Voltage Reference Module

---

### 20.4 VOLTAGE REFERENCE ACCURACY/ERROR

The full range of voltage reference cannot be realized due to the construction of the module. The transistors on the top and bottom of the resistor ladder network (Figure 20-1) keep the voltage reference from approaching the reference source rails. The voltage reference is derived from the reference source; therefore, the voltage reference output changes with fluctuations in that source. The tested absolute accuracy of the voltage reference can be found in **Section 20.9 “Electrical Specifications”**.

### 20.5 OPERATION DURING SLEEP

When the device wakes up from Sleep through an interrupt or a Watchdog Timer time-out, the contents of the CVRCON register are not affected. To minimize current consumption in Sleep mode, the voltage reference should be disabled.

### 20.6 EFFECTS OF A RESET

A device Reset disables the voltage reference by clearing bit, CVREN (CVRCON<7>). This Reset also disconnects the reference from the CVREF pin by clearing bit, CVROE (CVRCON<6>), and selects the high-voltage range by clearing bit, CVRR (CVRCON<5>). The CVR value select bits are also cleared.

## 20.7 CONNECTION CONSIDERATIONS

The voltage reference module operates independently of the comparator module. The output of the reference generator may be connected to the CVREF pin if the CVROE bit is set. Enabling the voltage reference output onto the I/O when it is configured as a digital input will increase current consumption. Configuring the port associated with CVREF as a digital output, with CVRSS enabled, will also increase current consumption.

The CVREF output pin can be used as a simple D/A output with limited drive capability. Due to the limited current drive capability, a buffer must be used on the voltage reference output for external connections to CVREF. Figure 20-2 shows a buffering technique example.

**Figure 20-2: Comparator Voltage Reference Output Buffer Example**

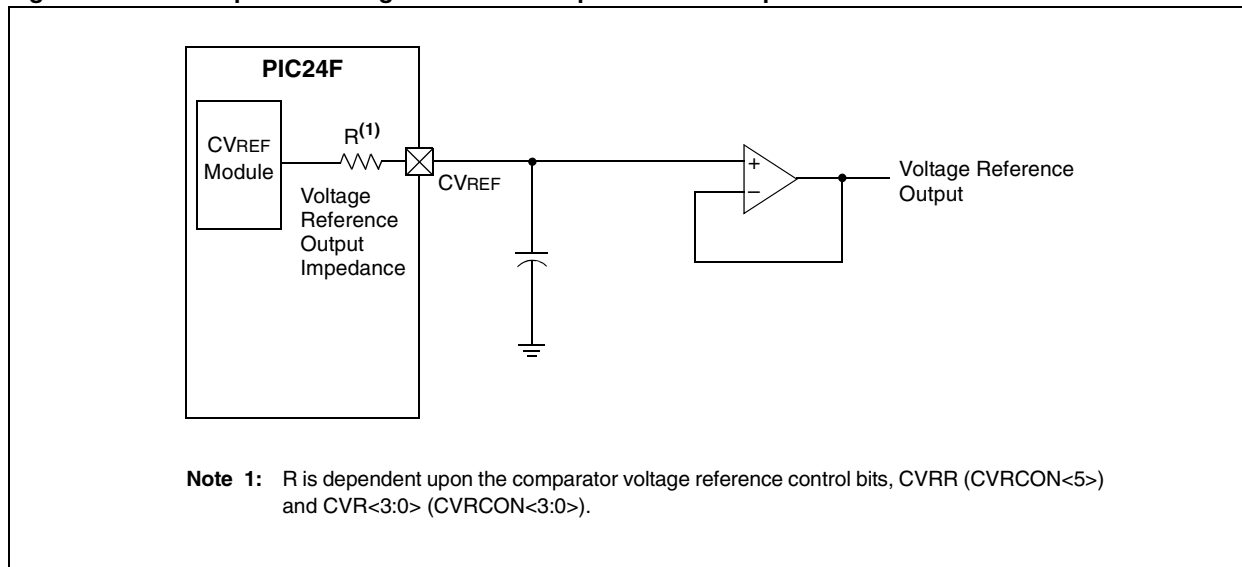

## 20.8 INITIALIZATION

This initialization sequence configures the comparator module as two independent comparators with outputs enabled and Comparator 1 output inverted. The comparator voltage reference module is configured for output enabled and set for  $0.25 * V_{DD}$ . Example 20-1 shows a program sequence to configure the voltage reference and comparator module. The delay used in this example is based off of an 8 MHz oscillator.

**Example 20-1: Voltage Reference Configuration**

```
CMCON      = 0x0F10;          //Initialize Comparator Module

CVRCON     = 0x00C0;          //Initialize Voltage Reference Module

CMCONbits.C1EVT = 0;          //Clear Comparator 1 Event
CMCONbits.C2EVT = 0;          //Clear Comparator 2 Event

asm volatile("repeat #40");   //Delay 10us
Nop();
```

# Section 20. Comparator Voltage Reference Module

## 20.9 ELECTRICAL SPECIFICATIONS

### 20.9.1 AC Characteristics

Table 20-2: Settling Time Specifications

Param No.	Symbol	Characteristic	Min	Typ	Max	Units	Comments
VR310	TSET	Settling Time <sup>(1)</sup>	—	—	TBD	μs	

**Legend:** TBD = To Be Determined

**Note 1:** Settling time measured while CVRR = 1 and CVR3:CVR0 bits transition from '0000' to '1111'.

### 20.9.2 DC Characteristics

Table 20-3: DC Specifications

Operating Conditions: 2.0V < VDD < 3.6V, -40°C < TA < +85°C (unless otherwise stated)							
Param No.	Symbol	Characteristic	Min	Typ	Max	Units	Comments
VRD310	CVRES	Resolution	CVRSRC/24	—	CVRSRC/32	LSb	
VRD311	CVRAA	Absolute Accuracy	—	—	TBD	LSb	
VRD312	CVRUR	Unit Resistor Value (R)	—	2k	—	Ω	

**Legend:** TBD = To Be Determined

## 20.10 DESIGN TIPS

**Question 1:** *My voltage reference is not what I expect.*

**Answer:** Any variation of the voltage reference source will translate directly onto the CVREF pin. Also, ensure that you have correctly calculated (specified) the voltage divider which generates the voltage reference.

**Question 2:** *I am connecting CVREF into a low-impedance circuit and the voltage reference is not at the expected level.*

**Answer:** The voltage reference module is not intended to drive large loads. A buffer must be used between the PICmicro® MCU device's CVREF pin and the load (see Figure 20-2).



## Section 20. Comparator Voltage Reference Module

---

### 20.11 RELATED APPLICATION NOTES

This section lists application notes that are related to this section of the manual. These application notes may not be written specifically for the PIC24F device family, but the concepts are pertinent and could be used with modification and possible limitations. The current application notes related to the Comparator Voltage Reference module are:

Title	Application Note #
Resistance and Capacitance Meter Using a PIC16C622	AN611
Make a Delta-Sigma Converter Using a Microcontroller's Analog Comparator Module	AN700
A Comparator Based Slope ADC	AN863
Oscillator Circuits for RTD Temperature Sensors	AN895
Temperature Measurement Circuits for Embedded Applications	AN929
Analog Sensor Conditioning Circuits – An Overview	AN990

**Note:** Please visit the Microchip web site ([www.microchip.com](http://www.microchip.com)) for additional application notes and code examples for the PIC24F family of devices.

## 20.12 REVISION HISTORY

### Revision A (June 2006)

This is the initial released revision of this document.